

Lenovo™

ThinkServer®

ThinkServer RD550  
User Guide and Hardware Maintenance  
Manual

ThinkServer

**Machine Types:** 70CV, 70CW, 70CX, 70CY, 70R3, 70R4, 70R5,  
70R6, 70S6, and 70S7

**Note:** Before using the information and the product it supports, be sure to read and understand the following:

- The *Read Me First* that comes with your product
- “Read this first: safety information” on page v
- Appendix F “Notices” on page 183

電子情報技術産業協会(JEITA) 表示

日本の定格電流が 20A/相 以下の機器に対する高調波電流規制  
高調波電流規格 JIS C 61000-3-2 適合品

本製品およびオプションに電源コード・セットが付属する場合は、それぞれ専用のものでありますので他の電気機器には使用しないでください。

**Eleventh Edition (November 2017)**

**© Copyright Lenovo 2014, 2017.**

LIMITED AND RESTRICTED RIGHTS NOTICE: If data or software is delivered pursuant to a General Services Administration “GSA” contract, use, reproduction, or disclosure is subject to restrictions set forth in Contract No. GS-35F-05925.

---

# Contents

## Read this first: safety information . . . . v

Products that are not assessed . . . . .	xi
Safety inspection guide . . . . .	xii
Grounding requirements . . . . .	xii

## Chapter 1. General information . . . . 1

Introduction . . . . .	1
Server documentation . . . . .	2

## Chapter 2. Server setup road map . . . 5

## Chapter 3. Product overview . . . . . 7

Server package . . . . .	7
Features . . . . .	7
Specifications . . . . .	11
Software . . . . .	12
BIOS and TSM update utilities . . . . .	12
Lenovo Partner Pack for Microsoft System Center Configurations Management . . . . .	13
Lenovo Partner Pack for Microsoft System Center Operations Management . . . . .	13
Lenovo Partner Pack for VMware vCenter . . . . .	13
Lenovo ThinkServer Deployment Manager . . . . .	13
Lenovo ThinkServer Diagnostics . . . . .	14
Lenovo ThinkServer Operating System-based Platform Update Tool . . . . .	14
Lenovo ThinkServer Power Planner . . . . .	14
Lenovo ThinkServer System Manager . . . . .	15
Lenovo ThinkServer System Manager Premium . . . . .	15
Lenovo XClarity Essentials OneCLI . . . . .	15
Lenovo XClarity Energy Manager . . . . .	15
Lenovo XClarity Administrator . . . . .	15

## Locations . . . . . 16

Machine type, model, and serial number label . . . . .	16
Front view of the server . . . . .	17
Front panel . . . . .	19
Rear view of the server . . . . .	21
Server components . . . . .	24
RAID adapter . . . . .	27
PCIe interposer card . . . . .	31
Backplane . . . . .	31
System board components . . . . .	35
System board switches . . . . .	38
System fan fault LEDs . . . . .	40
Hot-swap-drive status LEDs . . . . .	41
Power supply status LEDs . . . . .	42

Connecting cables . . . . .	43
-----------------------------	----

## Chapter 4. Turning on and turning off the server . . . . . 45

Turning on the server . . . . .	45
Turning off the server . . . . .	45

## Chapter 5. Configuring the server. . . 47

Using the Setup Utility program . . . . .	47
Starting the Setup Utility program . . . . .	47
Viewing information in the Setup Utility program . . . . .	47
Setup Utility program interface . . . . .	47
Setting the system date and time . . . . .	50
Using passwords . . . . .	50
Selecting a startup device . . . . .	51
Configuring the TPM function . . . . .	52
Setting an Ethernet connector for system management . . . . .	52
Exiting the Setup Utility program . . . . .	52
Updating or recovering the BIOS . . . . .	53
Configuring RAID . . . . .	54
About RAID. . . . .	55
Configuring RAID using the Lenovo ThinkServer Deployment Manager program . . . . .	56
Configuring the advanced SATA or SAS hardware RAID . . . . .	56
Updating the firmware . . . . .	57

## Chapter 6. Replacing hardware . . . . 59

Guidelines . . . . .	59
Precautions . . . . .	59
Handling static-sensitive devices . . . . .	60
System reliability guidelines . . . . .	60
Working inside the server with the power on . . . . .	61
Removing or extending the server from the rack cabinet . . . . .	61
Removing the server cover . . . . .	61
Installing, removing, or replacing hardware . . . . .	62
Removing and reinstalling the rack handles . . . . .	63
Removing and reinstalling the cooling shroud . . . . .	64
Installing or removing a memory module . . . . .	66
Installing or removing the ThinkServer System Manager Premium module. . . . .	71
Installing or removing the ThinkServer Trusted Platform Module. . . . .	73
Installing or removing the RAID 110i upgrade key . . . . .	75

Installing or removing the Lenovo ThinkServer RAID 510i/520i upgrade key . . . . .	77
Installing or removing the Thunderbolt Memory Module . . . . .	80
Installing or removing the SD module . . . . .	82
Installing or removing the M.2 storage module . . . . .	84
Installing or removing the AnyFabric adapter . . . . .	88
Installing or removing the ThinkServer RAID Super Capacitor Module . . . . .	91
Installing or removing a PCIe card . . . . .	93
Installing or removing the serial port module . . . . .	97
Installing or removing the optical module . . . . .	101
Installing or removing the rear backplane/cage kit . . . . .	104
Replacing the rear backplane. . . . .	106
Replacing the AnyRAID adapter. . . . .	108
Installing or removing the intrusion switch . . . . .	111
Installing or replacing a heat sink . . . . .	113
Installing or replacing the microprocessor . . . . .	115
Installing or replacing a hot-swap redundant power supply . . . . .	123
Installing or replacing a hot-swap hard disk drive . . . . .	126
Installing or replacing an easy-swap drive . . . . .	129
Installing or replacing a 2.5-inch drive . . . . .	131
Installing or replacing the optical drive . . . . .	137
Connecting an external tape drive . . . . .	139
Replacing the hot-swap hard-disk-drive backplane . . . . .	140
Replacing a system fan . . . . .	142
Replacing the front panel board. . . . .	143
Replacing the front VGA and USB module. . . . .	145
Replacing the riser card assembly . . . . .	147
Replacing the coin-cell battery . . . . .	149
For service technician only: replacing the system board . . . . .	150
Completing the parts replacement . . . . .	154
Reinstalling the server cover and reconnecting cables. . . . .	155
Updating the server configuration . . . . .	156

**Chapter 7. Troubleshooting and diagnostics. . . . .157**

Troubleshooting procedure . . . . .	157
Viewing the status and diagnostic LEDs . . . . .	157
Viewing the system event log . . . . .	158
Basic troubleshooting tables. . . . .	158
Lenovo ThinkServer Deployment Manager program problems . . . . .	158
Optical drive problems . . . . .	158
Storage drive problems . . . . .	159

Memory module problems . . . . .	160
Keyboard, mouse, and USB device problems . . . . .	161

**Chapter 8. Getting information, help, and service. . . . .163**

Information resources . . . . .	163
Using the documentation . . . . .	163
ThinkServer Web site . . . . .	163
Lenovo Support Web site . . . . .	163
Help and service . . . . .	164
Before you call . . . . .	164
Calling for service . . . . .	164
Using other services . . . . .	165
Purchasing additional services . . . . .	165

**Appendix A. Regulatory information. . . . .167**

Export classification notice . . . . .	167
Electronic emission notices . . . . .	167
Federal Communications Commission (FCC) Statement . . . . .	167
Japan VCCI Class A compliance statement . . . . .	169
Japanese statement for ac power consumption for JEITA harmonics guideline. . . . .	170
Japanese statement of compliance for products less than or equal to 20 A per phase for JEITA harmonics guideline . . . . .	170
Eurasian compliance mark . . . . .	170

**Appendix B. WEEE and recycling information. . . . .171**

Important WEEE information . . . . .	171
Recycling information for Japan . . . . .	171
Recycling information for Brazil. . . . .	172
Battery recycling information for the European Union. . . . .	172
Battery recycling information for the United States and Canada . . . . .	173
Requirement for batteries containing perchlorate . . . . .	173

**Appendix C. Restriction of Hazardous Substances (RoHS) Directive . . . . .175**

European Union RoHS . . . . .	175
Turkish RoHS . . . . .	175
Ukraine RoHS . . . . .	175
India RoHS . . . . .	175
China RoHS . . . . .	176
Taiwan BSMI RoHS declaration . . . . .	177

---

**Appendix D. Additional statements . . . . .179**  
Important notes . . . . . 179  
Particulate contamination . . . . . 179  
German Ordinance for Work gloss statement . . . 180

**Appendix E. ENERGY STAR model information. . . . .181**

**Appendix F. Notices . . . . .183**  
Trademarks . . . . . 184

**Index . . . . .185**



---

## Read this first: safety information

**Note:** Before using the product, be sure to read and understand the multilingual *Safety Information* on the Lenovo Web site at:

<https://support.lenovo.com/documents/LNVO-DOCS>

Lenovo *Safety Information* (معلومات السلامة) المتعددة اللغات وفهمها في موقع الويب.

Antes de usar o produto, certifique-se de ler e entender as *Safety Information* (Informações sobre segurança) multilíngues no site da Lenovo.

Преди да използвате продукта, прочетете и разберете многоезичната *Safety Information* (Информация за безопасност) на уебсайта на Lenovo.

Prije korištenja našeg proizvoda svakako s razumijevanjem pročitajte višejezični dokument *Safety Information* (Informacije o sigurnosti) na web-mjestu tvrtke Lenovo.

Před použitím tohoto produktu si nezapomeňte přečíst vícejazyčný dokument *Safety Information* (Bezpečnostní informace) na webu společnosti Lenovo.

Før du bruger produktet, skal du sørge for at læse og forstå *Safety Information* (sikkerhedsforskrifter), der findes på flere sprog, på Lenovos websted.

Lue monikielinen *Safety Information* (Turvaohjeet) -julkaisu Lenovon verkkosivustosta ennen tuotteen käyttöä.

Avant d'utiliser ce produit, prenez connaissance des *Safety Information* (Informations relatives à la sécurité) multilingues sur le site Web Lenovo.

Πριν χρησιμοποιήσετε το προϊόν, φροντίστε να διαβάσετε και να κατανοήσετε τις *Safety Information* (Πληροφορίες ασφαλείας) στο δικτυακό τόπο της Lenovo.

Vor Verwendung des Produkts sollten Sie die mehrsprachigen *Safety Information* (Sicherheitsinformationen) auf der Lenovo Website lesen und verstehen.

לפני השימוש במוצר, הקפידו לקרוא ולהבין את המסמך *Safety Information* (מידע בנושא בטיחות) המופיע בשפות רבות באתר האינטרנט של Lenovo.

A termék használatára előtt olvassa át, és ismerje meg a Lenovo webhelyén több nyelven is elérhető *Safety Information* (Biztonsági tájékoztató) című dokumentumot.

Prima di utilizzare il prodotto, accertarsi di leggere e comprendere la documentazione multilingua *Safety Information* (Informazioni sulla sicurezza) sul sito Web Lenovo.

製品をご使用になる前に、Lenovo Web サイトに掲載されているマルチリンガルの *Safety Information* (安全上の注意) を読んで理解してください。

제품을 사용하기 전에 Lenovo 웹 사이트의 다국어 *Safety Information* (안전 정보)를 주의 깊게 읽어보십시오.

Zorg dat u alle *Safety Information* (veiligheidsvoorschriften) op de website van Lenovo hebt gelezen en begrepen voordat u het product gebruikt.

Przed skorzystaniem z produktu należy zapoznać się z wielojęzycznym dokumentem *Safety Information* (Informacje dotyczące bezpieczeństwa), dostępnym w serwisie internetowym Lenovo.

Antes de utilizar o produto, certifique-se de que lê e compreende a documentação multilingue *Safety Information* (Informações sobre Segurança) no sítio da Web da Lenovo.

Înainte de a utiliza produsul, citiți și înțelegeți *Safety Information* (informațiile de siguranță) în mai multe limbi de pe site-ul web Lenovo.

Før du bruker produktet, må du lese og forstå den flerspråklige *Safety Information* (sikkerhetsinformasjonen) på nettstedet til Lenovo.

Перед использованием продукта обязательно ознакомьтесь с разделом *Safety Information* (Информация по технике безопасности), представленным на нескольких языках на веб-сайте Lenovo.

在使用产品之前，请务必先阅读和了解 **Lenovo Web** 站点上的多语言 *Safety Information* 《安全信息》。

Pre korišćenja proizvoda, obavezno pažljivo i sa razumevanjem pročitajte višezjezične *Safety Information* (Bezbednosne informacije) na veb lokaciji kompanije Lenovo.

Skôr než produkt začnete používať, prečítajte si viacjazyčné *Safety Information* (Bezpečnostné informácie) na webovej lokalite spoločnosti Lenovo.

Pred uporabo izdelka poskrbite, da boste prebrali in razumeli razdelek *Safety Information* (Varnostne informacije), ki je na spletnem mestu Lenovo na voljo v več jezikih.

Antes de usar el producto, asegúrese de leer y entender la sección *Safety Information* (Información de seguridad) multilingüe del sitio web de Lenovo.

Innan du använder den här produkten är det viktigt att du har läst och förstått den flerspråkiga *Safety Information* (säkerhetsinformationen) på Lenovos webbplats.

使用本產品之前，請務必先閱讀及瞭解 Lenovo 網站上多國語言版本的 *Safety Information* (安全資訊)。

Ürünü kullanmadan önce, Lenovo web sitesindeki *Safety Information* (Güvenlik Bilgileri) belgesini (birden çok dilde yayınlanmaktadır) mutlaka okuyun.

Перш ніж використовувати продукт, обов'язково прочитайте *Safety Information* (інструкції з техніки безпеки), доступні різними мовами на веб-сайті Lenovo.

ก่อนใช้ผลิตภัณฑ์นี้ โปรดอ่านและทำความเข้าใจกับ *Safety Information* (ข้อมูลความปลอดภัย) หลายภาษา บนเว็บไซต์ **Lenovo**

**Important:** Ensure that you read and understand all caution and danger statements in this document before you perform the procedures. Read and understand any additional safety information that is included with the server or optional device before you install, remove, or replace the device.

#### Statement 1



#### DANGER



Electrical current from power, telephone, and communication cables is hazardous.

To avoid a shock hazard:

- Do not connect or disconnect any cables or perform installation, maintenance, or reconfiguration of this product during an electrical storm.
- Connect all power cords to a properly wired and grounded electrical outlet.
- Ensure that all power cord connectors are securely and completely plugged into receptacles.
- Connect to properly wired outlets any equipment that will be attached to this product.
- When possible, use one hand only to connect or disconnect signal cables.
- Never turn on any equipment when there is evidence of fire, water, or structural damage.
- Disconnect the attached power cords, telecommunications systems, networks, and modems before you open the device covers, unless instructed otherwise in the installation and configuration procedures.
- Connect and disconnect cables as described in the following table when installing, moving, or opening covers on this product or attached devices.

To connect:

1. Turn everything OFF.
2. First, attach all cables to devices.
3. Attach signal cables to connectors.
4. Attach power cords to outlets.
5. Turn devices ON.

To disconnect:

1. Turn everything OFF.
2. First, remove power cords from outlets.
3. Remove signal cables from connectors.
4. Remove all cables from devices.

## Statement 2



**DANGER**

**Danger of explosion if battery is incorrectly replaced.**

When replacing the lithium coin cell battery, use only the same or an equivalent type that is recommended by the manufacturer. The battery contains lithium and can explode if not properly used, handled, or disposed of.

**Do not:**

- Throw or immerse into water
- Heat to more than 100°C (212°F)
- Repair or disassemble

Dispose of the battery as required by local ordinances or regulations.

## Statement 3



**CAUTION:**

When laser products (such as CD-ROMs, DVD drives, fiber optic devices, or transmitters) are installed, note the following:

- Do not remove the covers. Removing the covers of the laser product could result in exposure to hazardous laser radiation. There are no serviceable parts inside the device.

- Use of controls or adjustments or performance of procedures other than those specified herein might result in hazardous radiation exposure.

 **DANGER**

Some laser products contain an embedded Class 3A or Class 3B laser diode. Note the following: Laser radiation when open. Do not stare into the beam, do not view directly with optical instruments, and avoid direct exposure to the beam.

**Statement 4**

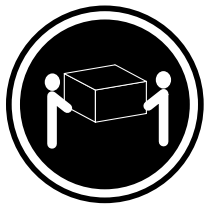

≥ 18 kg (39.7 lb)  
 < 32 kg (70.5 lb)

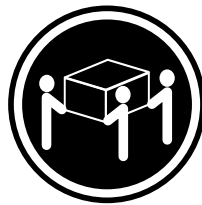

≥ 32 kg (70.5 lb)  
 < 55 kg (121.2 lb)

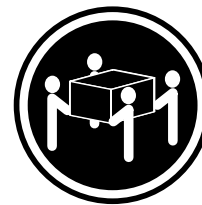

≥ 55 kg (121.2 lb)  
 < 100 kg (220.5 lb)

**CAUTION:**  
 Use safe practices when lifting.

**Statement 5**



**CAUTION:**  
 The power control button on the device and the power switch on the power supply do not turn off the electrical current supplied to the device. The device also might have more than one power cord. To remove all electrical current from the device, ensure that all power cords are disconnected from the power source.

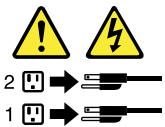

**Statement 6**



**CAUTION:**  
 If you install a strain-relief bracket option over the end of the power cord that is connected to the device, you must connect the other end of the power cord to a power source that is easily accessible in case it needs to be disconnected.

**Statement 7**



**CAUTION:**

If the device has doors, ensure that you remove or secure the doors before moving or lifting the device to protect against personal injury. The doors will not support the weight of the device.

**Statement 8**



**CAUTION:**

Never remove the cover on a power supply or any part that has the following label attached.



Hazardous voltage, current, and energy levels are present inside any component that has this label attached. There are no serviceable parts inside these components. If you suspect a problem with one of these parts, contact a service technician.

**Statement 9**



**CAUTION:**

Disconnect the hot-swap fan cables before removing the fan from the device to protect against personal injury.

**Statement 10**



**CAUTION:**

The following label indicates a sharp-edge hazard.



**Statement 11**



**CAUTION:**

The following label indicates a potential heat hazard.



### Statement 12



### DANGER

Overloading a branch circuit is a potential fire hazard and a shock hazard under certain conditions. To avoid these hazards, ensure that your system electrical requirements do not exceed branch current ratings at the installation site.

### Statement 13



### CAUTION:

Ensure that the rack is secured properly to avoid tipping when the server unit is extended on the rails.

### Statement 14



### CAUTION:

Some accessory or option board outputs exceed Class 2 or limited power source limits. You must install the appropriate interconnecting cabling in accordance with your local electrical code requirements.

### Statement 15



### CAUTION:

The power-control button on the device may put the device in standby mode instead of turning off the device. In addition, the device might have multiple connections to dc power. To remove all electrical current from the device, ensure that all connections to dc power are disconnected at the dc power input terminals.

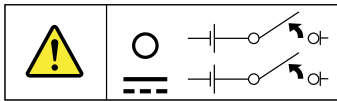

### Statement 16



### CAUTION:

To reduce the risk of electric shock or energy hazards:

- This equipment must be installed by trained service personnel in a restricted-access location, as defined by your local electrical code and the latest edition of IEC 60950.
- The branch circuit overcurrent protection must be rated in accordance with local electrical code requirements.
- Use 1.3 mm<sup>2</sup> or 16 American Wire Gauge (AWG) copper conductor only, not exceeding 3 meters in length.

- Torque the wiring-terminal screws to 1.4 newton-meters or 12 inch-pounds.
- Provide a readily available, approved and rated disconnect device in the field wiring.

Statement 17



**CAUTION:**

This product contains a Class 1M laser. Do not view directly with optical instruments.

Statement 18



**CAUTION:**

Do not place any object on top of rack-mounted products.



Statement 19



**CAUTION:**

Hazardous moving parts. Keep fingers and other body parts away.

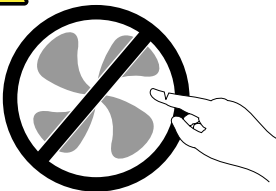

Statement 20



**CAUTION:**

A lithium ion battery is provided. To avoid possible explosion, do not burn the battery. Replace the battery only with the Lenovo-approved part. Recycle or discard the battery as instructed by local regulations.

---

## Products that are not assessed

Typical products that are **not assessed** include but not limited to the following:

- Server and IT-rack components (for example, uninterruptible power supplies and current distribution systems)
- Devices in IT rooms (for example, bulk storage units and network products)

- Industrial low-voltage switchgear

---

## Safety inspection guide

The purpose of this inspection guide is to assist you in identifying potentially unsafe conditions. As each machine was designed and built, required safety items were installed to protect users and service technicians from injury. This guide addresses only those items. You should use good judgment to identify potential safety hazards due to attachment of non-ThinkServer features or options not covered by this inspection guide.

If any unsafe conditions are present, you must determine how serious the apparent hazard could be and whether you can continue without first correcting the problem.

Consider these conditions and the safety hazards they present:

- Electrical hazards, especially primary power (primary voltage on the frame can cause serious or fatal electrical shock)
- Explosive hazards, such as a damaged Cathode Ray Tube (CRT) monitor or a bulging capacitor
- Mechanical hazards, such as loose or missing hardware

To determine whether there are any potentially unsafe conditions, use the following checklist at the beginning of every service task. Begin the checks with the power off, and the power cords disconnected.

Checklist:

1. Check exterior covers for damage (loose, broken, or sharp edges).
2. Power off the server. Disconnect the power cords.
3. Check the power cord for:
  - a. A third-wire ground connector in good condition. Use a meter to measure third-wire ground continuity for 0.1 ohm or less between the external ground pin and the frame ground.
  - b. The power cord should be the authorized type specified for your server. Go to: <http://www.lenovo.com/serviceparts-lookup>.
  - c. Insulation must not be frayed or worn.
4. Check for cracked or bulging batteries.
5. Remove the cover.
6. Check for any obvious non-ThinkServer alterations. Use good judgment as to the safety of any non-ThinkServer alterations.
7. Check inside the unit for any obvious unsafe conditions, such as metal filings, contamination, water or other liquids, or signs of fire or smoke damage.
8. Check for worn, frayed, or pinched cables.
9. Check that the power-supply cover fasteners (screws or rivets) have not been removed or tampered with.

---

## Grounding requirements

Electrical grounding of the server is required for operator safety and correct system function. Proper grounding of the electrical outlet can be verified by a certified electrician.

---

# Chapter 1. General information

This chapter provides some general information about your product.

This chapter contains the following items:

- “Introduction” on page 1
- “Server documentation” on page 2

---

## Introduction

This document for your Lenovo® ThinkServer® product contains information about the server features, specifications, component locations, configuration instructions, hardware replacement procedures, and basic troubleshooting and diagnostics.

Your server comes with the Lenovo ThinkServer Deployment Manager program that provides a convenient solution for configuring the server and installing an operating system.

The Lenovo Limited Warranty (LLW) contains the warranty terms that apply to the product you purchased from Lenovo. The LLW is available at [http://www.lenovo.com/warranty/llw\\_02](http://www.lenovo.com/warranty/llw_02). If you cannot obtain the LLW through the Lenovo Web site, contact your local Lenovo office or reseller to obtain a printed version of the LLW, free of charge.

For warranty service, consult the worldwide Lenovo Support telephone list. Telephone numbers are subject to change without notice. The most up-to-date telephone list for Lenovo Support is always available on the Web site at <http://www.lenovo.com/support/phone>. If the telephone number for your country or region is not listed, contact your Lenovo reseller or Lenovo marketing representative.

To obtain the most up-to-date information about the server, go to:  
<http://www.lenovo.com/thinkserver>

Lenovo maintains pages on the World Wide Web, where you can get the latest technical information and download documentation or device drivers and updates. To access the Lenovo Support Web site, go to:  
<http://www.lenovo.com/support>

Record information about your server in the following table. You will need the information if you ever need to have your server serviced.

For where to find the product information label on the chassis, see “Machine type, model, and serial number label” on page 16.

<b>Product name</b>	_____
<b>Machine type and model (MT-M)</b>	_____
<b>Serial number (S/N)</b>	_____

Date of purchase \_\_\_\_\_

You can register your server with Lenovo by following the instructions at:  
<http://www.lenovo.com/register>

When you register your server, information is entered into a database, which enables Lenovo to contact you in case of a recall or other severe problem. After you register your server with Lenovo, you will receive quicker service when you call Lenovo for help. In addition, some locations offer extended privileges and services to registered users.

---

## Server documentation

This topic provides general descriptions of the various documentation for your server and instructions on how to obtain all the documentation.

### Printed documents

The following documents are printed out and contained in your server package.

- *Read Me First*

This is a multilingual document. It illustrates safety symbols and instructs you to read the complete safety, warranty, and support information provided on the Lenovo Web site before using the server. This document also tells you how to find the most up-to-date information on the Lenovo Support Web site. In addition, recycling, environmental, and legal notices are all included.

- *A letter to customers*

This is a multilingual letter to customers, which tells customers that Lenovo is undertaking a paperless electronic documentation initiative to protect environment. This letter also provides information about how to contact Lenovo if you require a printed version of any electronic documents.

- *Rack Installation Instructions*

This document provides instructions on how to install your server into a standard rack by using the rail kit shipped with the server.

**Note:** A printed English version of this document is included in your server package. PDF versions of other languages are provided at <http://www.lenovo.com/support>.

### Electronic documents

- You can find the following electronic documents at <https://support.lenovo.com/documents/LNVO-DOCS>:

- *Safety Information*

This is a multilingual document that includes all the safety statements for your product. Ensure that you read and understand these safety statements before using the product.

- *Lenovo Limited Warranty*

This document includes the Lenovo terms and warranty statements.

- *Lenovo License Agreement*

This document includes the terms and conditions of the Lenovo License Agreement.

- You can find the following electronic documents at the Lenovo Support Web site. Go to <http://www.lenovo.com/support>, click **Documentation**, and follow the instructions on the screen to find the document you need.



- *Safety, Warranty, and Support Information*

This is a multilingual document that includes all the safety statements for your product in more than 30 languages. Be sure to read and understand all the safety statements before using the product. This document also includes the Lenovo warranty statement, Customer Replaceable Units (CRUs) information, and information about how to contact the Lenovo Customer Support Center.

- *User Guide and Hardware Maintenance Manual*

This document provides detailed information to help you get familiar with your server and help you use, configure, and maintain your server.

- *Rack Installation Instructions*

This document provides instructions on how to install your server into a standard rack by using the rail kit shipped with the server.

- *ThinkServer System Manager User Guide (English only)*

This document provides information about server remote management.

**Note:** To obtain advanced remote management functions, install a ThinkServer System Manager Premium (TSM Premium) module on the TSM Premium connector on the system board. See “Installing or removing the ThinkServer System Manager Premium module” on page 71.

- *MegaRAID SAS Software User Guide (English only)*

This document provides information about Redundant Array of Independent Disks (RAID) and how to use the utility programs to configure, monitor, and maintain your server RAID and related devices.

- *Other documents*

You might find other documents for the Host Bus Adapter (HBA), Ethernet card, or other optional parts.



---

## Chapter 2. Server setup road map

This chapter provides a general road map to guide you through setting up your server.

The server setup procedure varies depending on the configuration of the server when it was delivered. In some cases, the server is fully configured and you just need to connect the server to the network and an ac power source, and then you can turn on the server. In other cases, the server needs to have hardware features installed, requires hardware and firmware configuration, and requires an operating system to be installed.

The general procedure for setting up your server is:

1. Unpack the server package. See “Server package” on page 7.
2. Install any required hardware or server option. See the related topics in Chapter 6 “Replacing hardware” on page 59.
3. If you have a rail kit, install your server into a standard rack cabinet. See the *Rack Installation Instructions* that comes with the server.
4. Connect the Ethernet cable and power cords to the server. See “Rear view of the server” on page 21 to locate the connectors.
5. Turn on the server to verify operation. See “Turning on the server” on page 45.
6. Review the Unified Extensible Firmware Interface (UEFI) settings and customize as needed. See “Using the Setup Utility program” on page 47.
7. Configure RAID and install the operating system and basic drivers. See “Lenovo ThinkServer Deployment Manager” on page 13 and “Configuring RAID” on page 54.
8. Install any additional drivers needed for added features. Refer to the instructions that come with the hardware option.
9. Configure Ethernet settings in the operating system by referring to the operating system help. This step is not required if the operating system was installed using the Lenovo ThinkServer Deployment Manager program.
10. Check for firmware and driver updates. See “Updating the firmware” on page 57.
11. Install other applications. Refer to the documentation that comes with the applications that you want to install.



---

## Chapter 3. Product overview

This chapter provides information about the server package, features, specifications, software programs, and component locations.

This chapter contains the following items:

- “Server package” on page 7
- “Features” on page 7
- “Specifications” on page 11
- “Software” on page 12
- “Locations” on page 16

---

### Server package

The server package includes the following items:

- Server
- Rail kit (available on some models)
- Cable management arm or cable management bar (available on some models)
- Slim optical drive (available on some models)
- Material box, including items such as power cords (available on some models) and printed documentation

---

### Features

This topic provides general information about the server features for various models. Depending on your specific model, some features might vary or unavailable. For information about your specific model, use the Setup Utility program. See “Viewing information in the Setup Utility program” on page 47. You also can refer to the *Product Specifications Reference* document for ThinkServer products at:

<http://www.lenovo.com/psref/>

#### Microprocessor

One or two Intel® Xeon® microprocessors (internal cache size varies by model)

#### Memory

Your server has 24 memory slots. For more information, see “Memory module installation rules” on page 66.

#### Power supply

- One or two 550-watt hot-swap redundant power supplies (Universal input and compliant with 80 PLUS Platinum)
- One or two 750-watt hot-swap redundant power supplies (Universal input and compliant with 80 PLUS Platinum)
- One or two 750-watt hot-swap redundant power supplies (Universal input and compliant with 80 PLUS Titanium)
- One or two 1100-watt hot-swap redundant power supplies (Universal input and compliant with 80 PLUS Platinum)

**Notes:**

- If you are using uninterruptible power supplies (UPS), ensure that you use only pure-sine UPS with your ThinkServer server.
- For 550-watt, 750-watt, or 1100-watt Platinum power supply: 90 - 264 V ac
- For 750-watt Titanium power supply: 180 - 264 V ac
- For machine types 70CX and 70CY, if you want to use 550-watt power supplies on these servers, ensure that the microprocessor power does not exceed 135 W. Meanwhile, within the required range, if the microprocessor power is higher than 105 W, the server supports at most 16 memory modules installed.

**System fans**

Your server supports up to eight hot-swap system fans with redundancy. This design helps you to avoid significant cooling problems when a system fan fails. You can replace a hot-swap system fan without turning off the server.

**Internal drives**

Internal drives are devices that your server uses to read and store data. The internal drives supported by your server vary by model. Some server models support AnyBay. The AnyBay technology enables you to use the bay for any drive technology (SATA/SAS/PCIe). A PCIe interposer card must be installed to support AnyBay. For more information, see “PCIe interposer card” on page 31.

- Storage drives:
  - Hot-swap SATA/SAS hard disk drive (HDD)
  - Hot-swap SATA/SAS solid-state drive (SSD)
  - Easy-swap PCIe SSD (supported only by AnyBay drive bays)
- Optical drive: slim SATA optical drive (available on some models)

For more information about drive and backplane configurations, see “Backplane” on page 31.

**Notes:**

- Acronyms and abbreviations for your reference:
  - SATA: Serial Advanced Technology Attachment
  - SAS: Serial Attached SCSI (SCSI: Small Computer System Interface)
  - PCIe: Peripheral Component Interconnect Express
- You can install SATA/SAS HDDs, SATA/SAS SSDs, and PCIe SSDs (if supported) into the same server.
- The following server models also are available:
  - Server models without HDDs or SSDs
  - Server models without HDDs, SSDs, backplanes, AnyRAID adapters, and related cables

**Expansion slots**

- Two riser card assembly slots on the system board
- One or two PCI Express (PCIe) card slots on the riser card
- One or two AnyFabric slots at the rear of the server

For detailed information, see “Rear view of the server” on page 21.

**Input/Output (I/O) features**

- On the rear panel:
  - One RJ-45 Ethernet connector for system management
  - Two USB 3.0 connectors
  - One VGA connector (DB-15)
  - One serial port (available on some models)
- On the front panel (available on some models):
  - One VGA connector (DB-15)
  - Two USB 2.0 connectors

For the location information about the connectors, refer to the related topics in “Locations” on page 16.

### **Video subsystem**

An integrated graphics controller is available in your server to support the VGA connectors for connecting video devices. The integrated graphics controller is located in the Baseboard Management Controller (BMC) chip on the system board.

- Integrated graphics controller: On-board ASPEED AST2400
- 16 MB of video memory cache

### **Ethernet connectivity**

There is one RJ-45 Ethernet connector on the rear panel with 10 megabits per second (Mbps), 100 Mbps, or 1000 Mbps network connectivity. The Ethernet connector is for system management.

You can install an Ethernet card or an AnyFabric adapter to enable more Ethernet connectors. However, you must install a device driver to enable the operating system to recognize the Ethernet connectors. The device drivers are available for download at:

<http://www.lenovo.com/drivers>

For more information, see “Rear view of the server” on page 21.

### **Reliability, availability, and serviceability**

Reliability, availability, and serviceability (hereinafter referred to as RAS) are three important server design features. The RAS features help you to ensure the integrity of the data stored on the server, the availability of the server when you need it, and the ease with which you can diagnose and correct problems.

Your server has the following RAS features:

- **Security features**

- Administrator password and user password to help protect unauthorized access to the server (see “Using passwords” on page 50)
- ThinkServer Trusted Platform Module (TPM), which is a security chip, to help enhance server security

**Note:** The TPM is only available on some models.

- Remote monitoring or control by an administrator to provide protection or help
- Hot-swap redundant power supplies to help avoid significant interruption to the operation of the system when a power supply fails
- An intrusion switch that informs you that the server cover is not properly installed or closed by creating an event in the system event log (SEL)

- **Basic system management features**

- Ability to store the power-on self-test (POST) hardware test results
- BIOS Setup Utility program

The BIOS Setup Utility program helps you view the server information and configure the server in the pre-operating system environment. See “Using the Setup Utility program” on page 47.

- TSM (also known as BMC) and Intelligent Platform Management Interface (IPMI) 2.0

The system board platform management subsystem is based on the integrated TSM features. The TSM is a management chip that is integrated on the system board of your server. With the TSM, no matter what condition the server operating system is in and no matter if the server is on or off, as long as the server is connected to network and an ac power source, the interaction with the TSM-controlled servers can be achieved through system network. The user can obtain the server hardware health information and system event log (SEL), and is able to conduct the operations including turning on or off the server, restarting the server, and so on. This part of server management is independent of the operating system and is called out-of-band management.

The system board platform management subsystem consists of the integrated TSM, communication buses, sensors, the BIOS, and server management firmware. It is responsible for error reporting, system power control, thermal monitoring, system fan control, and other management features. The TSM provides system management and monitoring features based on the IPMI 2.0 specification. IPMI helps lower the overall costs of server management. You can find more information about IPMI 2.0 from the Web site of Intel. The TSM also supports some non-IPMI features, such as the Dynamic Host Configuration Protocol (DHCP) and the Platform Environment Control Interface (PECI), to provide more system management functions.

You can find the default user name, password, and other information for the TSM in the *ThinkServer System Manager User Guide*, which is available for download at:

<http://www.lenovo.com/UserManuals>

- Hot-swap feature

Your server supports hot-swap storage drives (including hard disk drives and solid-state drives), hot-swap system fans, and hot-swap redundant power supplies. With the hot-swap feature, you can install, remove, or replace a hot-swap device without turning off the server.

- Preboot Execution Environment (PXE)

The Intel PXE technology enables you to boot your computers, load an operating system, or deploy executable images from a remote server by using a network interface. The operation can be done independently of local data storage devices (such as hard disk drives) or operating systems.

- Redundant Array of Independent Disks (RAID)

Your server supports onboard SATA software RAID. If a required RAID card is installed, your server also supports advanced SATA/SAS hardware RAID configurations. For detailed information, see “Configuring RAID” on page 54.

- Status light-emitting diodes (LEDs) and diagnostic LEDs

For more information about the LEDs for your server, refer to the related topics in “Locations” on page 16.

- Software programs

For more information about the software programs, see “Software” on page 12.

- Wake on LAN

Wake on LAN is an Ethernet computer networking standard that allows a computer or a server to be turned on or woken up by a network message. The message is usually sent by a program running on another computer on the same local area network.

- **Advanced system management features**



The advanced system management features are only available when the TSM detects the presence of a TSM Premium module. The TSM Premium module is a remote management module. You can purchase a TSM Premium module from Lenovo and install it on the system board to activate the advanced system management features.

For more information about advanced system management, refer to the *ThinkServer System Manager User Guide*, which is available for download at:

<http://www.lenovo.com/UserManuals>

---

## Specifications

This topic lists the physical specifications for your server.

### Dimensions

Width without rack handles: 447 mm (17.59 inches)

Width with rack handles: 482 mm (18.98 inches)

Depth without rack handles and power supply handles: 779.8 mm (30.70 inches)

Depth with rack handles and power supply handles: 802.8 mm (31.61 inches)

Height: 43 mm (1.69 inches)

### Weight

The product weight varies depending on different system configurations.

Range of product weight without package: 13.5 kg (29.76 lb) to 21 kg (46.29 lb)

Range of product weight with package: 17.3 kg (38.14 lb) to 24.8 kg (54.67 lb)

### Environment

Your server complies with ASHRAE class A2 specifications.

**Notes:** Your server supports a maximum operating temperature of 30°C (86°F) if it comes with one of the following configurations:

- 145-watt CPU, four 3.5-inch drives
- 145-watt CPU, twelve 2.5-inch drives

Depending on the hardware configuration, some server models comply with ASHRAE class A3 and class A4 specifications. To comply with ASHRAE class A3 and class A4 specifications, your server models need to meet the following hardware configuration requirements at the same time:

- Lenovo-qualified CPU except the following types:
  - 135-watt CPU (4-core, 6-core, or 8-core)
  - 145-watt CPU (14-core or 18-core)
- Two power supplies (except the 1100-watt power supplies) installed for redundancy

The following table provides detailed information about the ASHRAE class specifications.

Table 1. ASHRAE class specifications

	ASHRAE class A2	ASHRAE class A3	ASHRAE class A4
Air temperature (operating)	10°C to 35°C (50°F to 95°F)	5°C to 40°C (41°F to 104°F)	5°C to 45°C (41°F to 113°F)
Air temperature (storage)	-40°C to 60°C (-40°F to 140°F) in original shipping package	-40°C to 60°C (-40°F to 140°F) in original shipping package	-40°C to 60°C (-40°F to 140°F) in original shipping package
Humidity (operating)	8% to 80% (non-condensing)	8% to 85% (non-condensing)	8% to 90% (non-condensing)
Humidity (storage)	8% to 90% (non-condensing)	8% to 90% (non-condensing)	8% to 90% (non-condensing)
Altitude	0 to 3048 m (0 to 10 000 ft) in an unpressurized environment  <b>Note:</b> When the altitude exceeds 900 m (2953 ft), the defined maximum dry-bulb temperature for operation becomes a dependent variable.  A2: This temperature value decreases by 1 °C (33.8 °F) with every 300 m (984 ft) of altitude increase.  A3: This temperature value decreases by 1 °C (33.8 °F) with every 175 m (574 ft) of altitude increase.  A4: This temperature value decreases by 1 °C (33.8 °F) with every 125 m (410 ft) of altitude increase.		

## Electrical input

- Universal input:
  - Low range:
    - Minimum: 100 V ac
    - Maximum: 127 V ac
    - Input frequency range: 50 to 60 Hz
  - High range:
    - Minimum: 200 V ac
    - Maximum: 240 V ac
    - Input frequency range: 50 to 60 Hz

---

## Software

This topic provides information about the software programs that you can use to set up, use, and maintain the server.

To download the software programs, go to the Lenovo Support Web site at <http://www.lenovo.com/support> and follow the instructions on the Web page.

## BIOS and TSM update utilities

The BIOS and TSM (also known as BMC) firmware keeps updating after the shipment of the server. Lenovo maintains pages on the Support Web site and provides the BIOS and TSM update utilities with instructions for download to help you update the BIOS and TSM firmware if needed. For more information, see “Updating or recovering the BIOS” on page 53 and “Updating the firmware” on page 57.

## **Lenovo Partner Pack for Microsoft System Center Configurations Management**

The Lenovo Partner Pack for Microsoft System Center Configurations Management (SCCM) program helps you manage the firmware components in your ThinkServer server. The firmware components include TSM, BIOS, Deployment Manager Application, Windows Driver Package for Deployment Manager, and Linux Driver Package for Deployment Manager. The program also enables users to send e-mail alerts to related recipients when certain events are detected.

For detailed information about using the program, refer to the help system of the program.

## **Lenovo Partner Pack for Microsoft System Center Operations Management**

The Lenovo Partner Pack for Microsoft System Center Operations Management program can automatically detect the managed servers and provide detailed system information about the servers. The system information includes the inventory and status of components such as microprocessors, memory modules, fans, and temperature sensors. The program also enables you to perform management tasks, such as restarting or turning off your server, starting a remote console, and accessing the TSM interface.

For detailed information about using the program, refer to the help system of the program.

## **Lenovo Partner Pack for VMware vCenter**

The Lenovo Partner Pack for VMware vCenter program provides detailed system information about the managed servers of your ThinkServer server in the VMware virtualized environment. The system information includes the inventory and status of components such as microprocessors, memory modules, fans, and temperature sensors. The program enables users to perform tasks such as launching a remote console and accessing the TSM interface. The program also provides an easy way to update the firmware and send e-mail alerts to related recipients when certain events are detected.

For detailed information about using the program, refer to the help system of the program.

## **Lenovo ThinkServer Deployment Manager**

The Lenovo ThinkServer Deployment Manager program (hereinafter referred to as Deployment Manager) simplifies the process of configuring RAID, configuring BIOS settings, and updating the firmware. The program works in conjunction with your Windows or Linux operating system installation disc to automate the process of installing the operating system and associated device drivers. The program is part of the server firmware. The help system for the program can be accessed directly from the program interface.

Deployment Manager has the following features:

- Easy-to-use, language-selectable interface
- Integrated help system
- Automatic hardware detection
- Selectable partition size and file system type
- Ability to install the operating system and device drivers in an unattended mode to save time
- Ability to create a reusable response file that can be used with similarly configured Lenovo servers to make future installations even faster
- Contains RAID configuration utility
- Provides device drivers based on the server model and detected devices
- Supports BIOS settings configuration

- Supports firmware and applications update

To use Deployment Manager, do the following:

1. Launch the program through one of the following methods:
  - Turn on the server. Press F10 as soon as you see the logo screen. Then, wait for several seconds. Deployment Manager opens.
  - Start the Setup Utility program. Select **Boot Manager → Launch TDM**. Deployment Manager opens.
2. Read and accept the license agreement.
3. Select the language in which you want to view the program. Then, follow the instructions on the screen to use the program.

Before installing a Windows or a Linux operating system using Deployment Manager, it is recommended that you do the following:

1. Download the latest device driver bundle file for your server. To find and download the bundle file, go to <http://www.lenovo.com/drivers> and follow the instructions on the Web page.
2. Launch Deployment Manager and click **Platform Update** on the left pane.
3. Select **Application** and then click **Next**.
4. Click **Browse** to select the corresponding bundle file and then click **OK**. The version information is displayed.
5. Click **Flash** to apply the bundle file and update the current device drivers.

**Note:** If you want to install a VMware hypervisor using Deployment Manager, the device driver bundle file is not needed.

To download the latest Deployment Manager, go to <http://www.lenovo.com/drivers> and follow the instructions on the Web page.

## Lenovo ThinkServer Diagnostics

The Lenovo ThinkServer Diagnostics program enables you to diagnose server problems offline, perform some diagnostic tests, and collect system information. Examples of the system information include basic operating-system information, hardware information, SEL, RAID log, and so on. Depending on the model, your server might come with one of the following diagnostic program editions:

- Lenovo ThinkServer Diagnostics Embedded Edition
- Lenovo ThinkServer Diagnostics Standalone Edition

For more information about Lenovo ThinkServer Diagnostics, go to <http://support.lenovo.com/us/en/lenovodiagnosicsolutions/downloads>. Locate the **Lenovo ThinkServer Diagnostics** section at the bottom of the Web page. Then, click the desired link for more information.

## Lenovo ThinkServer Operating System-based Platform Update Tool

The Lenovo ThinkServer Operating System-based Platform Update Tool is used to update the firmware in the operating system for your server.

For detailed information about using the program, refer to the help system of the program.

## Lenovo ThinkServer Power Planner

The Lenovo Thinkserver Power Planner program provides information about the power consumption and electric current calculation based on the different configurations of servers and other devices. The program also helps to plan servers and devices deployment in an efficient way.

For detailed information about using the Lenovo ThinkServer Power Planner program, refer to the help system of the program.

## **Lenovo ThinkServer System Manager**

The Lenovo ThinkServer System Manager (TSM) is a management solution that provides comprehensive and secure management features. These features enable you to manage your servers remotely using a one-to-one or one-to-many method.

The TSM provides a one-to-one web-based console. The web-based console is developed in HTML 5 and structured in the way that makes platform management intuitive and efficient. The TSM also provides a secure command-line interface to manage your servers using a one-to-many method for improved efficiency and functionality.

For detailed information about using the Lenovo ThinkServer System Manager, refer to the integrated help screens and user guides.

## **Lenovo ThinkServer System Manager Premium**

Lenovo ThinkServer System Manager Premium provides you a solution that enables you to receive all the benefits and features provided by both the Lenovo ThinkServer System Manager program and the Lenovo ThinkServer Energy Manager program. It also enables you to control the server remotely using Lenovo virtual keyboard, video, and mouse.

For detailed information about using the Lenovo ThinkServer System Manager Premium features and tools, refer to the integrated help screens and user guides.

## **Lenovo XClarity Essentials OneCLI**

Lenovo XClarity Essentials OneCLI consists of individual application modules that utilize a command-line interface (CLI) to help you manage servers. With the inventory application module, Lenovo XClarity Essentials OneCLI enables you to get inventory and system information for ThinkServer servers.

For more information about Lenovo XClarity Essentials OneCLI, go to:  
<https://support.lenovo.com/solutions/HT116433?LinkTrack=Solr>

## **Lenovo XClarity Energy Manager**

Lenovo XClarity Energy Manager (hereinafter referred to as Energy Manager) is a program for data center power management. It monitors the power and temperature at the device level and the group level. By monitoring and analyzing power and temperature information, Energy Manager helps you to increase power efficiency and improve business continuity.

For information about using Energy Manager, refer to the help system of the program.

## **Lenovo XClarity Administrator**

Lenovo XClarity Administrator is a centralized resource-management solution that enables administrators to deploy infrastructure faster and with less effort. The solution seamlessly integrates into System x, ThinkServer, and NeXtScale servers, as well as the Flex System converged infrastructure platform.

Lenovo XClarity Administrator provides the following features:

- Automated discovery and inventory
- Bare metal deployment
- Security management

- Upward integration
- Python CLI, representational state transfer (REST) application programming interfaces (APIs), and Windows PowerShell
- Simple network management protocol (SNMP), system log, and e-mail forwarding

For more information about Lenovo XClarity Administrator, go to:

[http://pic.dhe.ibm.com/infocenter/flexsys/information/index.jsp?topic=%2Fcom.lenovo.lxca.doc%2Faug\\_product\\_page.html](http://pic.dhe.ibm.com/infocenter/flexsys/information/index.jsp?topic=%2Fcom.lenovo.lxca.doc%2Faug_product_page.html)

---

## Locations

This topic provides information to help you locate your server components.

### Machine type, model, and serial number label

When you contact Lenovo for help, the machine type, model, and serial number information helps support technicians to identify your server and provide faster service.

The machine type, model, and serial number label is attached on the pull-out information card, which is a small plastic tab and can be slid out of the front of the chassis. The following illustrations are samples of the machine type, model, and serial number labels on server models with different hard disk drive configurations.

**Note:** Depending on the model, your server might look slightly different from the illustrations in this topic.

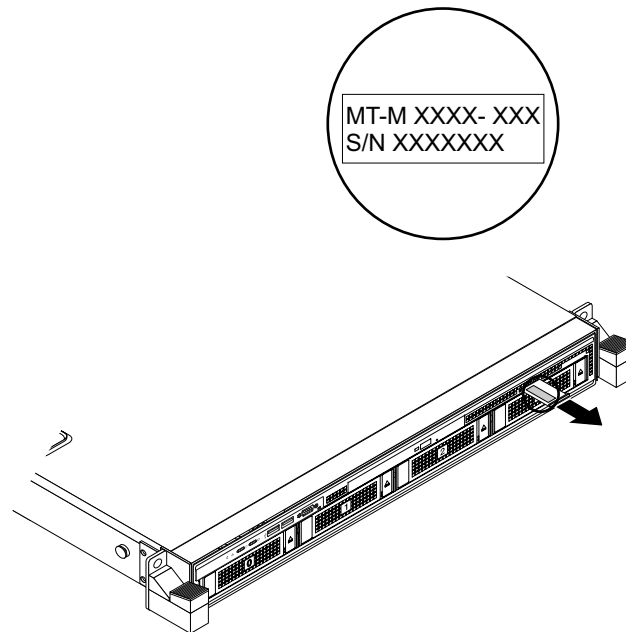

Figure 1. Label on server models with 3.5-inch-drive bays

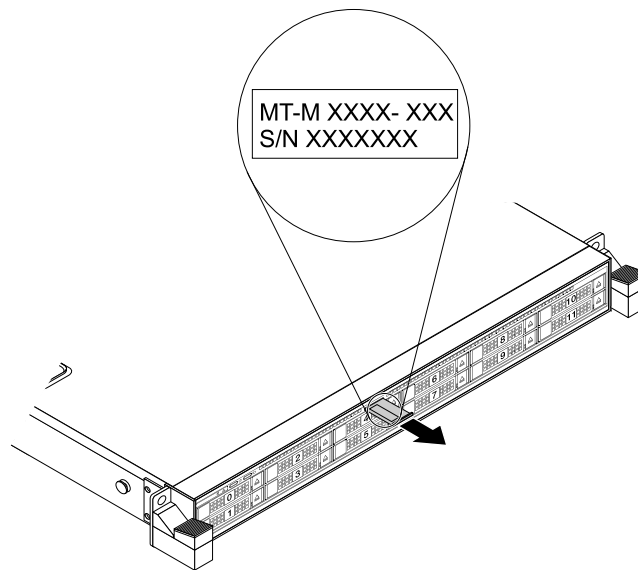

Figure 2. Label on server models with 2.5-inch-drive bays

## Front view of the server

The front view of the server varies by model. The illustrations in this topic show the server front views based on the supported internal drives:

- “Front view of server models with 3.5-inch drives” on page 17
- “Front view of server models with 2.5-inch drives” on page 18

**Note:** Depending on the model, your server might look slightly different from the illustrations in this topic.

### Front view of server models with 3.5-inch drives

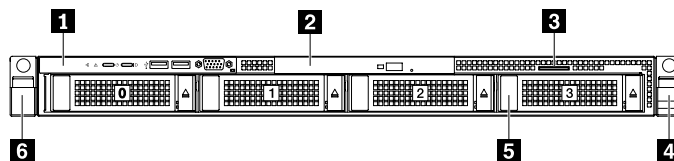

Figure 3. Front view of server models with 3.5-inch drives

<b>1</b> Front panel	<b>2</b> Slim optical drive (available on some models)
<b>3</b> Pull-out information card	<b>4</b> Rack handle (right)
<b>5</b> 3.5-inch-drive bays (0-3)	<b>6</b> Rack handle (left)

#### **1** Front panel

For detailed information about the controls, connectors, and status LEDs on the front panel, see “Front panel” on page 19.

#### **2** Slim optical drive (available on some models)

Some server models come with a slim SATA optical drive.

#### **3** Pull-out information card

The machine type, model, and serial number label of the server is attached on the pull-out information card. See “Machine type, model, and serial number label” on page 16.

**4 Rack handle (right)**

**6 Rack handle (left)**

If your server is installed in a rack cabinet, you can use the rack handles to help you slide the server out of the rack cabinet. You also can use the rack handles and screws to secure the server in the rack cabinet so that the server cannot slide out, especially in vibration-prone areas. For more information, refer to the *Rack Installation Instructions* that comes with your server.

**5 3.5-inch-drive bays (0-3)**

The EMI integrity and cooling of the server are protected by having all drive bays covered or occupied. The number of the installed hard disk drives in your server varies by model. The vacant hard-disk-drive bays are occupied by dummy hard-disk-drive trays.

When you install drives, follow the order of the drive bay numbers.

**Front view of server models with 2.5-inch drives**

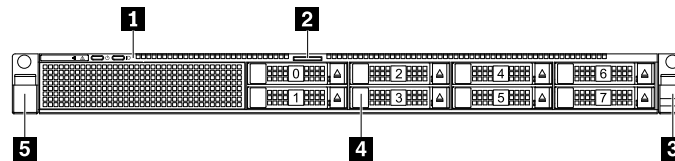

Figure 4. Front view of server models with eight 2.5-inch drives

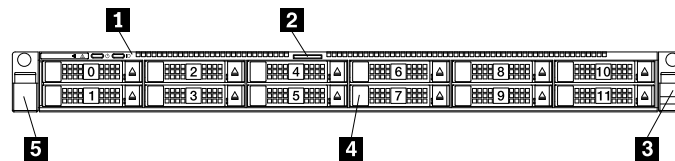

Figure 5. Front view of server models with twelve 2.5-inch drives

<b>1</b> Front panel	<b>2</b> Pull-out information card
<b>3</b> Rack handle (right)	<b>4</b> 2.5-inch-drive bays
<b>5</b> Rack handle (left)	

**1 Front panel**

For detailed information about the controls, connectors, and status LEDs on the front panel, see “Front panel” on page 19.

**2 Pull-out information card**

The machine type, model, and serial number label of the server is attached on the pull-out information card. See “Machine type, model, and serial number label” on page 16.

**3 Rack handle (right)**

**5 Rack handle (left)**



If your server is installed in a rack cabinet, you can use the rack handles to slide the server out of the rack cabinet; or use the rack handles and screws to secure the server in the rack cabinet so that the server cannot slide out, especially in vibration-prone areas. For more information, refer to the *Rack Installation Instructions* that comes with your server.

#### 4 2.5-inch-drive bays

**Note:** On some server models, the bays 10 and 11 also support 2.5-inch easy-swap-drives.

The EMI integrity and cooling of the server are protected by having all drive bays covered or occupied. The number of the installed drives in your server varies by model. The vacant drive bays are occupied by dummy trays.

When you install drives, follow the order of the drive bay numbers.

## Front panel

The following illustration shows the controls, connectors, and LEDs on the front panel of the server. The front panel varies by model.

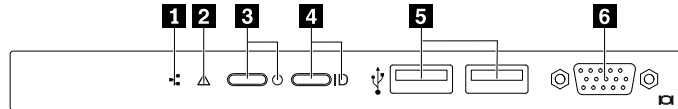

Figure 6. Front panel for server models with 3.5-inch-drive bays

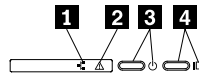

Figure 7. Front panel for server models with 2.5-inch-drive bays

<b>1</b> Network status LED	<b>2</b> System health LED
<b>3</b> Power button with power status LED	<b>4</b> System ID button with ID LED
<b>5</b> USB 2.0 connectors (2) (available on some models)	<b>6</b> VGA connector (DB-15)

### 1 Network status LED

The network status LED on the front panel helps you identify the network connectivity and activity.

Status	Color	Description
Blinking	Green	The AnyFabric network is connected and active.
Off	None	The server is disconnected from the AnyFabric network or the AnyFabric network is not active.

### 2 System health LED

The system health LED helps you to determine if there are any system errors.

- **Off:** The server is off or the server is on and working correctly.
- **Amber:** The server has potential system errors. Check the information in the following table for potential system errors and corresponding solutions.

- **Blinking:** System initialization is ongoing.

Potential system error (system health LED: amber)	Solution
The temperature of the server reached the non-critical temperature threshold.	Check the BMC for errors and check the system fans.
The voltage of the server reached the non-critical voltage threshold.	Replace the system board. <b>Note:</b> This action must be performed only by Lenovo service personnel. See Chapter 8 “Getting information, help, and service” on page 163.
A fan is running at low speed.	Check the system fans.
A hot-swap fan has been removed.	<ol style="list-style-type: none"> <li>1. Ensure that the system fans are connected securely to the system board.</li> <li>2. Reinstall the removed fan or install a new fan to replace the removed fan.</li> </ol>
The power supply has a critical error.	Check the BMC for detailed information.
A power cord has been disconnected or a redundant power supply has been removed.	<ol style="list-style-type: none"> <li>1. Ensure that the power supplies are installed securely.</li> <li>2. Ensure that the power cords are connected securely to the power supplies.</li> <li>3. Install a new power supply to replace the removed one.</li> </ol>
The system is overheated.	Check the BMC for errors and then check the system fans.

### 3 Power button with power status LED

You can press the power switch to turn on the server when you finish setting up the server. You also can hold the power switch for several seconds to turn off the server if you cannot turn it off from the operating system. See Chapter 4 “Turning on and turning off the server” on page 45. The power status LED helps you to determine the current power status.

Status	Color	Description
On	Green	The server is on.
Off	None	The server is off.

### 4 System ID button with ID LED

When you press the system ID button, the ID LEDs on both the front and rear of the server are lit to help you locate the server among other servers. You also can turn on the ID LEDs using a remote management program for server presence detection.

Status	Color	Description
On	Blue	The system is identified.
Off	None	The ID LED is not in use or the system is not identified.

### 5 USB 2.0 connectors (2) (available on some models)

Used to attach a USB-compatible device, such as a USB keyboard, mouse, scanner, or printer. If you have more than four USB devices, you can purchase a USB hub, which you can use to connect additional USB devices.

**6 VGA connector (DB-15)** (available on some models)

Used to attach a VGA-compatible video device, such as a VGA monitor.

## Rear view of the server

This topic provides information to help you locate the connectors and components on the rear of your server.

The following illustration shows the connectors and components on the rear of your server. The rear view of the server varies by model.

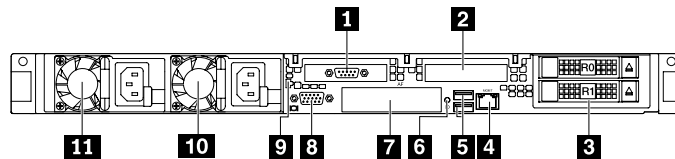

Figure 8. Rear view of server models with 3.5-inch drives

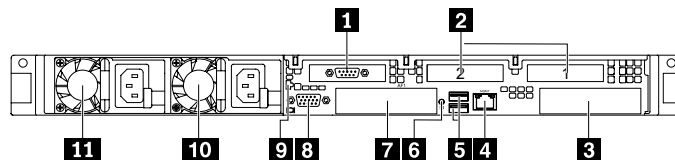

Figure 9. Rear view of server models with 2.5-inch drives

<b>1</b> Serial port module (available on some models)	<b>2</b> One or two PCIe slots
<b>3</b> Rear 2.5-inch-drive bays or AnyFabric slot 2	<b>4</b> Ethernet connector for system management (RJ-45)
<b>5</b> USB 3.0 connectors (2)	<b>6</b> System ID LED
<b>7</b> AnyFabric slot 1	<b>8</b> VGA connector (DB-15)
<b>9</b> Fiber cable release tool	<b>10</b> Hot-swap redundant power supply 2 (available on some models)
<b>11</b> Hot-swap redundant power supply 1	

**1 Serial port module** (available on some models)

Used to connect to a device that uses a serial port.

**2 PCIe slots**

Used to attach an Ethernet card or any other supported PCIe card.

Physical link width	Negotiable link width	Supported card length and height
x16	x16, x8, x4, x2, x1	Low-profile card
x8	x8, x4, x2, x1	Low-profile card

### 3 Rear 2.5-inch-drive bays

Used to install up to two 2.5-inch drives.

### 3 AnyFabric slot 2

Used to install an AnyFabric adapter (also called mezzanine adapter).

### 4 Ethernet connector for system management (RJ-45)

Used to attach an Ethernet cable for a LAN. The Ethernet connector has two status LEDs to help you identify the Ethernet connectivity, activity, and connection speed.

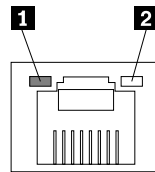

Ethernet status LED	Color	Status	Description
1 Left	Amber	On	The connection speed is 1000 Mbps.
	Green	On	The connection speed is 100 Mbps.
	None	Off	The connection speed is 10 Mbps.
2 Right	Green	On	The server is connected to a LAN.
	None	Off	The server is disconnected from a LAN.
	Green	Blinking	The LAN is connected and active.

### 5 USB 3.0 connectors (2)

Used to attach a USB-compatible device, such as a USB keyboard, mouse, scanner, or printer. If you have more than four USB devices, you can purchase a USB hub, which you can use to connect additional USB devices.

### 6 System ID LED

When you press the ID button on the front panel, the ID LEDs on both the front and rear of the server are lit to help you locate the server among other servers. You also can turn on the ID LEDs using a remote management program for server presence detection.

Status	Color	Description
On	Blue	The system is identified.
Off	None	The ID LED is not in use or the system is not identified.

### 7 AnyFabric slot 1

Used to install an AnyFabric adapter (also called mezzanine adapter).

### 8 VGA connector (DB-15)

Used to attach a VGA-compatible video device, such as a VGA monitor.

## **10** Hot-swap redundant power supply 2 (available on some models)

## **11** Hot-swap redundant power supply 1

The hot-swap redundant power supplies help you avoid significant interruption to the operation of the system when a power supply fails. You can purchase a power supply option from Lenovo and install the power supply to provide power redundancy without turning off the server.

On each power supply, there are three status LEDs near the power cord connector. For information about the status LEDs, see “Power supply status LEDs” on page 42.

## **9** Fiber cable release tool

A fiber cable release tool (FRU part number 00FC501) is attached to the rear of your server. This tool helps you release the fiber cable from the PCIe card with an optical module.

### **Using the fiber cable release tool**

To use the fiber cable release tool, do the following:

1. Locate the fiber cable release tool and then remove it from the rear of the server.

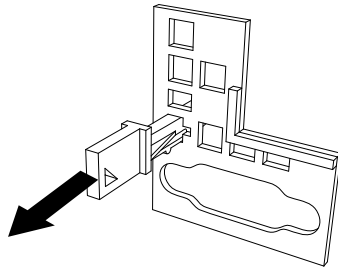

*Figure 10. Removing the fiber cable release tool*

2. Insert the fiber cable release tool under the fiber cable latch. Then, press the handle of the fiber cable release tool downwards.

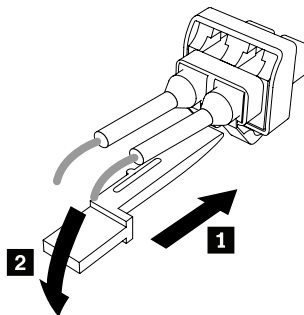

*Figure 11. Using the fiber cable release tool*

3. Remove the fiber cable from the PCIe card.

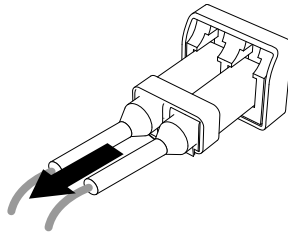

Figure 12. Removing the fiber cable

4. Reinstall the fiber cable release tool to the rear of the server for future use.

## Server components

This topic provides information to help you locate the components of your server. For more information about major components, see the related topics in “Locations” on page 16.

To remove the server cover and the cooling shroud and gain access to the inside of the server, see “Removing the server cover” on page 61 and “Removing and reinstalling the cooling shroud” on page 64.

The chassis configuration varies by model. The following illustrations show the two chassis configurations based on the supported drives.

- Server models with 3.5-inch drives
- Server models with 2.5-inch drives

**Note:** Depending on the model, your server might look slightly different from the illustrations in this topic.

The following illustration shows the components of server models with 3.5-inch drives.

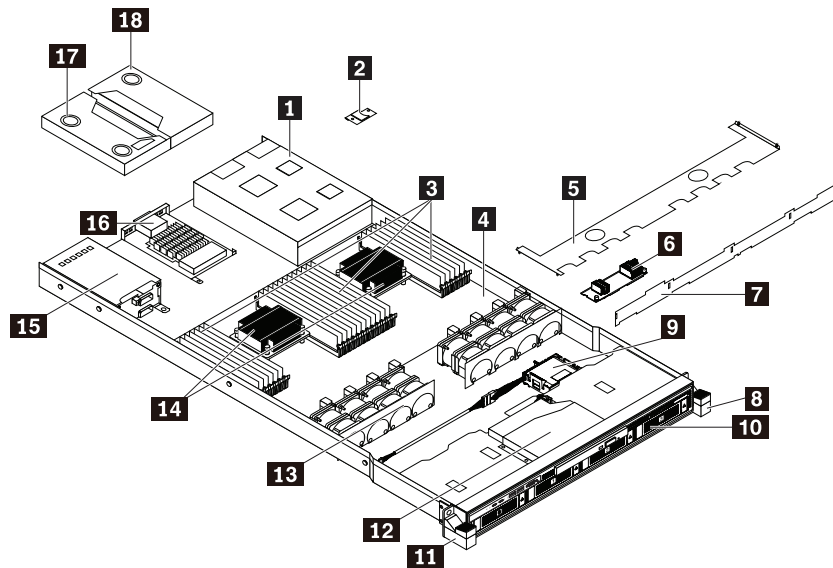

Figure 13. Components of server models with 3.5-inch drives

<b>1</b> One or two hot-swap redundant power supplies	<b>2</b> Secure digital (SD) module (available on some models)
<b>3</b> DIMMs (vary by model)	<b>4</b> System board
<b>5</b> Cooling shroud	<b>6</b> AnyRAID adapter

<b>7</b> Front backplane for 3.5-inch drives	<b>8</b> Rack handle (right)
<b>9</b> ThinkServer RAID Super Capacitor Module (available on some models)	<b>10</b> 3.5-inch-drive area
<b>11</b> Rack handle (left)	<b>12</b> Slim optical drive (available on some models)
<b>13</b> System fans	<b>14</b> Heat sink(s) with microprocessor(s) underneath
<b>15</b> Rear backplane/cage assembly (available on some models)	<b>16</b> AnyFabric adapter 1 (available on some models)
<b>17</b> Riser card assembly 1	<b>18</b> Riser card assembly 2

The following illustration shows the components of server models with twelve 2.5-inch drives.

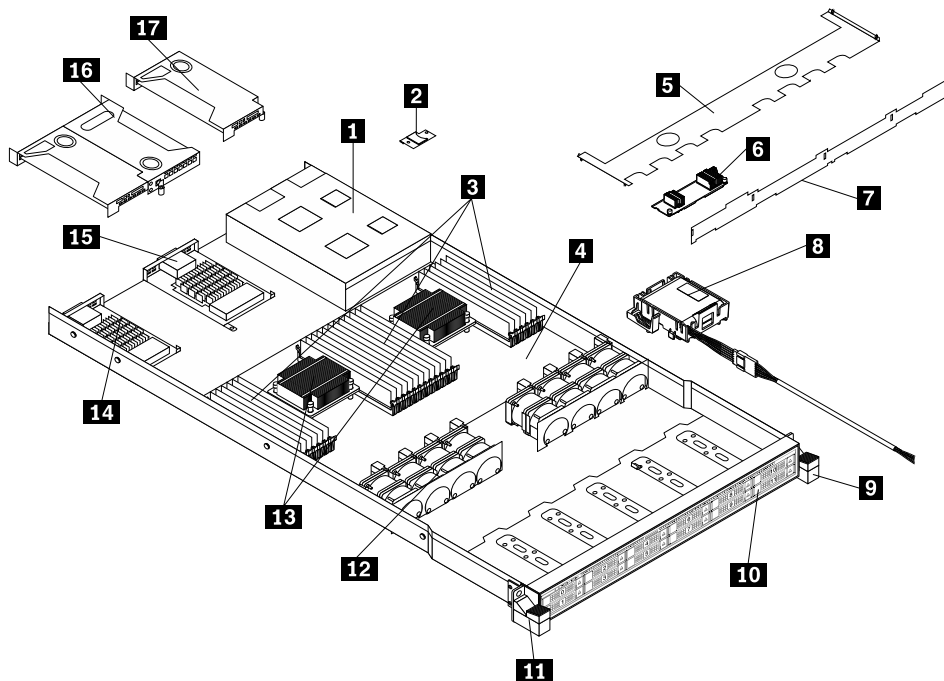

Figure 14. Components of server models with twelve 2.5-inch drives

<b>1</b> One or two hot-swap redundant power supplies	<b>2</b> SD module (available on some models)
<b>3</b> DIMMs (installed memory modules vary by model)	<b>4</b> System board
<b>5</b> Cooling shroud	<b>6</b> AnyRAID adapter
<b>7</b> Front backplane for 2.5-inch drives	<b>8</b> ThinkServer RAID Super Capacitor Module (available on some models)
<b>9</b> Right rack handle	<b>10</b> 2.5-inch-drive area
<b>11</b> Left rack handle	<b>12</b> System fans
<b>13</b> Heat sink(s) with microprocessor(s) underneath	<b>14</b> AnyFabric adapter 2 (available on some models)
<b>15</b> AnyFabric adapter 1 (available on some models)	<b>16</b> Riser card assembly 1
<b>17</b> Riser card assembly 2	

CRUs are parts that can be upgraded or replaced by the customer. If a CRU is determined to be defective during the warranty period, a replacement CRU will be provided to the customer. Customers are responsible for installing the self-service CRUs for this product. Customers also can install optional-service CRUs, which might require some technical skills or tools, or request that a technician install the optional-service CRU under the terms of the applicable warranty service type for your country or region.

Non-CRUs must be replaced only by trained service technicians.

The following table lists the major FRUs in your server and the CRU identification information. For a complete listing of FRU information, such as FRU part numbers and supported server models, go to:

<http://www.lenovo.com/serviceparts-lookup>

**Notes:**

- Before servicing a Lenovo product, ensure that you read and understand “Read this first: safety information” on page v.
- Use only parts provided by Lenovo.

\* Available on some models

FRU description	Self-service CRU	Optional-service CRU
AnyFabric adapter*	Yes	No
AnyRAID adapter	No	Yes
Coin-cell battery	Yes	No
Cooling shroud	Yes	No
Easy-swap PCIe solid-state drive*	Yes	No
Easy-swap storage drive*	Yes	No
Front backplane	No	Yes
Front panel board	Yes	No
Heat sink	Yes	No
Hot-swap storage drive*	Yes	No
Hot-swap redundant power supply	Yes	No
Intrusion switch*	Yes	No
Memory module	Yes	No
Microprocessor	No	Yes
M.2 storage module*	No	Yes
Optical module*	Yes	No
PCIe card	Yes	No
Power cord	Yes	No
Rack handles	Yes	No
Rear backplane	Yes	No
Rear backplane/cage assembly*	Yes	No
Riser card	Yes	No
SD card*	Yes	No



FRU description	Self-service CRU	Optional-service CRU
SD module*	No	Yes
Slim optical drive*	Yes	No
System board	No	No
System fan	Yes	No
ThinkServer RAID 110i upgrade key*	No	Yes
ThinkServer RAID 510i upgrade key*	No	Yes
ThinkServer RAID 520i upgrade key*	No	Yes
ThinkServer RAID 720i Modular Flash*	No	Yes
ThinkServer RAID 720i Modular DRAM Upgrade*	No	Yes
ThinkServer RAID Super Capacitor Module*	No	Yes
ThinkServer System Manager Premium module*	Yes	No
ThinkServer Trusted Platform Module*	Yes	No
Front VGA and USB module*	Yes	No
Serial port module*	Yes	No

## RAID adapter

Your server supports the following RAID adapters (supported type varies by server model):

- Lenovo ThinkServer RAID 110i AnyRAID Adapter (also called pass-through board)
- Lenovo ThinkServer RAID 510i AnyRAID Adapter
- Lenovo ThinkServer RAID 720i AnyRAID Adapter
- Lenovo ThinkServer RAID 720ix AnyRAID Adapter
- Lenovo ThinkServer RAID 520i PCIe Adapter
- Lenovo ThinkServer RAID 720i PCIe Adapter

**Note:** If your server comes with the Lenovo ThinkServer RAID 110i AnyRAID Adapter, do not use the Lenovo ThinkServer X710-4 AnyFabric 10Gb 4 Port SFP+ Ethernet Adapter by Intel (hereinafter referred to as the X710-4 AnyFabric adapter). The X710-4 AnyFabric adapter is not active in this situation.

You can purchase a supported RAID adapter from Lenovo and install it into the server. For a list of ThinkServer options, go to <http://lenovoquickpick.com/usa/home/thinkserver/rack-and-tower-server>. The option kit is designed for different types of servers and might contain additional cables that are not required for your server.

The following illustrations help you locate the connectors on the RAID adapters. Depending on the configuration, the RAID adapter installed in your server might look slightly different from the illustrations in this topic.

### Lenovo ThinkServer RAID 110i AnyRAID Adapter

The Lenovo ThinkServer RAID 110i AnyRAID Adapter is used to provide SATA software RAID function. The following illustration shows the connectors on the adapter.

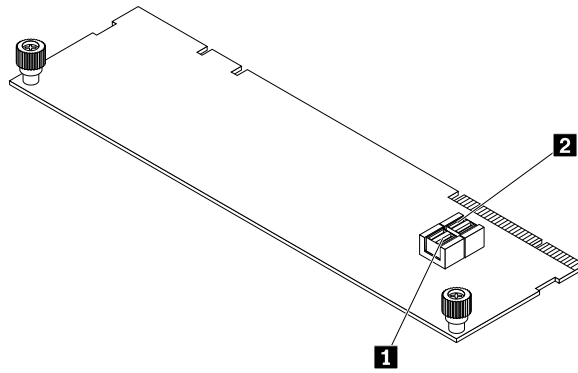

Figure 15. Lenovo ThinkServer RAID 110i AnyRAID Adapter

**1 SATA connector 0-3**

Used to connect to the SATA connector 0 (ports 0-3) on the system board. See “System board components” on page 35.

**2 SATA connector 4-7**

Used to connect to the SATA connector 1 (ports 4-7) on the system board. See “System board components” on page 35.

**Lenovo ThinkServer RAID 510i AnyRAID Adapter**

The Lenovo ThinkServer RAID 510i AnyRAID Adapter provides advanced SATA/SAS hardware RAID functions. The following illustration shows the connectors on the adapter.

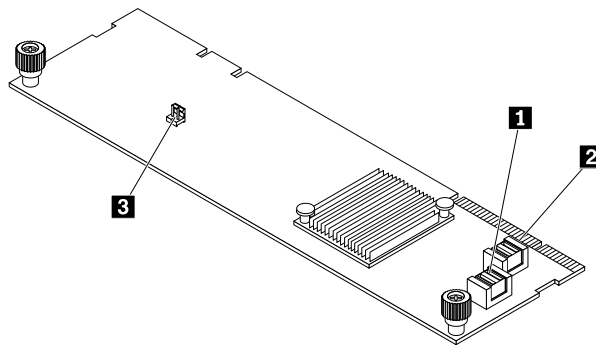

Figure 16. Lenovo ThinkServer RAID 510i AnyRAID Adapter

**1 PCI-E 0 connector**

**2 PCI-E 1 connector**

Used to connect to the AnyRAID connector 0-1 on the system board. See “System board components” on page 35.

**3 RAID upgrade key connector**

Used to connect a ThinkServer RAID 510i upgrade key.

**Lenovo ThinkServer RAID 720i AnyRAID Adapter**

The Lenovo ThinkServer RAID 720i AnyRAID Adapter provides advanced SATA/SAS hardware RAID functions. The following illustration shows the connectors on the adapter.

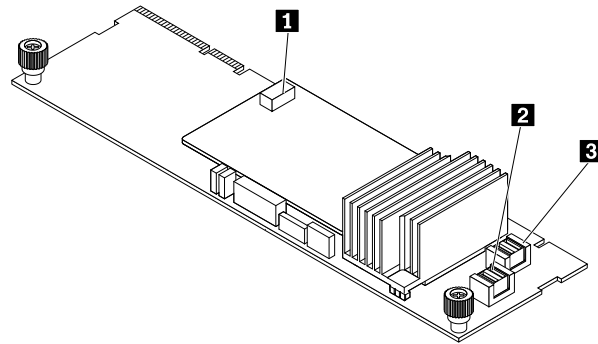

Figure 17. ThinkServer RAID 720i AnyRAID Adapter

**1 ThinkServer RAID Super Capacitor Module connector** (available on some models)

Used to connect to the ThinkServer RAID Super Capacitor Module. See “Server components” on page 24.

**2 PCI-E 0 connector**

**3 PCI-E 1 connector**

Used to connect to the AnyRAID connector 0 and 1 on the system board. See “System board components” on page 35.

**ThinkServer RAID 720ix AnyRAID Adapter**

The Lenovo ThinkServer RAID 720ix AnyRAID Adapter provides advanced SATA/SAS hardware RAID functions. The following illustration shows the connectors on the adapter.

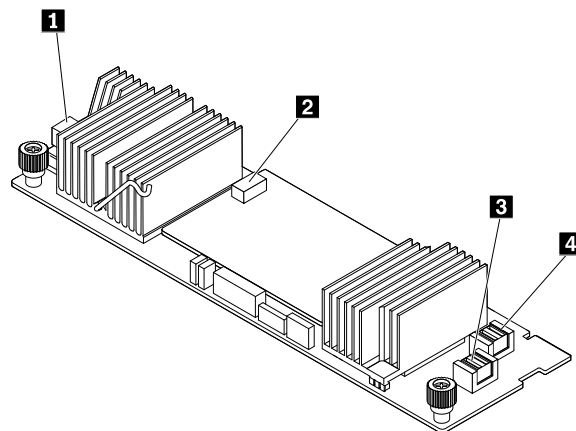

Figure 18. ThinkServer RAID 720ix AnyRAID Adapter

**1 SATA connector**

Used to connect the SATA signal cable from any of the following component:

- M.2 storage module (available on some models)
- Rear backplane for up to two 2.5-inch drives (available on some models)

## **2 ThinkServer RAID Super Capacitor Module connector**

Used to connect to the ThinkServer RAID Super Capacitor Module. See “Server components” on page 24.

## **3 PCI-E 0 connector**

## **4 PCI-E 1 connector**

Used to connect to the AnyRAID connector 0 and 1 on the system board. See “System board components” on page 35.

## **Lenovo ThinkServer RAID 520i PCIe Adapter**

The Lenovo ThinkServer RAID 520i PCIe Adapter provides advanced SATA/SAS hardware RAID functions. The following illustration shows the connectors on the adapter.

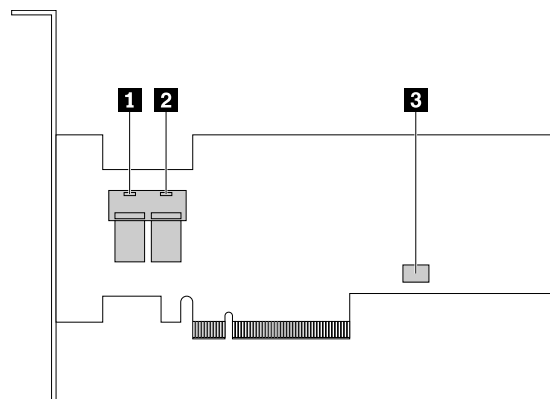

Figure 19. Lenovo ThinkServer RAID 520i PCIe Adapter

## **1 Connector 0**

Used to connect the mini-SAS signal cable connector on the backplane for eight 2.5-inch drives to support HDD 0-3.

## **2 Connector 1**

Used to connect the mini-SAS signal cable connector on the backplane for eight 2.5-inch drives to support HDD 4-7.

## **3 J3 connector**

Used to connect to a Lenovo ThinkServer RAID 520i RAID 5 Upgrade Key.

## **Lenovo ThinkServer RAID 720i PCIe Adapter**

The RAID 720i Adapter provides advanced SATA/SAS hardware RAID functions. The following illustration shows the connectors on the adapter.

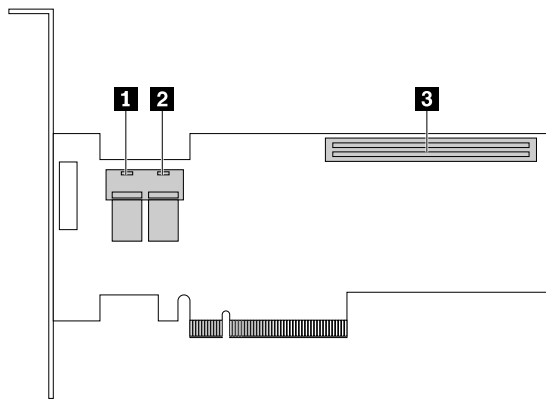

Figure 20. ThinkServer RAID 720i PCIe Adapter

**1 Connector 0**

Used to connect the mini-SAS signal cable connector on the backplane for eight 2.5-inch drives to support HDD 0-3.

**2 Connector 1**

Used to connect the mini-SAS signal cable connector on the backplane for eight 2.5-inch drives to support HDD 4-7.

**3 Thunderbolt Flash Module connector**

Used to connect a Thunderbolt Memory module (hereinafter referred to as TMM).

## PCIe interposer card

The PCIe interposer card is used in server models that support easy-swap PCIe SSD drives for AnyBay. The following illustration shows the connectors on the PCIe interposer card.

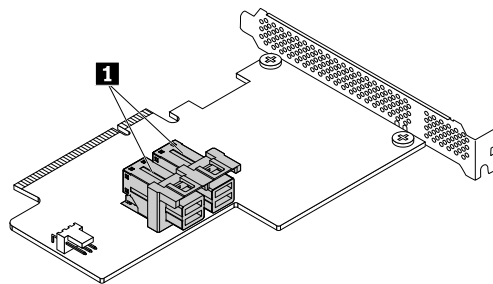

Figure 21. PCIe interposer card

**1 PCIe connector**

Used to connect the signal cable to the PCIe signal connectors on the backplane for 2.5-inch drives. See “Backplane for up to twelve 2.5-inch drives” on page 34.

## Backplane

Your server supports the following backplanes:

- Backplane for up to four 3.5-inch drives



- Backplane for up to eight 2.5-inch drives
- Backplane for up to twelve 2.5-inch drives
- Rear backplane for up to two 2.5-inch drives (available on some models)

To locate the backplanes, see “Server components” on page 24.

The following tables list the backplane and drive configurations for different server models. Depending on the model, your server might look slightly different from the illustrations in the following table.

- In the front:

Your server comes with one of the following backplane and drive configurations:

Backplane and drive configuration	Drive type
One backplane for up to four 3.5-inch drives 	<ul style="list-style-type: none"> <li>– Hot-swap SATA/SAS HDD</li> <li>– Hot-swap SATA/SAS SSD</li> </ul>
One backplane for up to eight 2.5-inch drives 	<ul style="list-style-type: none"> <li>– Hot-swap SATA/SAS HDD</li> <li>– Hot-swap SATA/SAS SSD</li> </ul>
One backplane for up to twelve 2.5-inch drives 	<ul style="list-style-type: none"> <li>– Hot-swap SATA/SAS HDD</li> <li>– Hot-swap SATA/SAS SSD</li> <li>– Easy-swap PCIe SSD (supported only by AnyBay* drive bays 10 and 11)</li> </ul>

**Notes:**

- \*: A PCIe interposer card must be installed to support AnyBay. For more information, see “PCIe interposer card” on page 31
- You can install a 2.5-inch drive into a 3.5-inch-drive bay. For more information, see “Installing a 2.5-inch drive into a 3.5-inch hard-disk-drive bay” on page 132.
- In the rear: (for server models with four 3.5-inch drives only)

Backplane quantity	Drive bay size	Drive bay quantity	Drive type
1	2.5-inch	2	Hot-swap SATA HDD/SSD

**Backplane for up to four 3.5-inch drives**

The following illustrations show the slots and connectors on the backplane for up to four 3.5-inch drives.

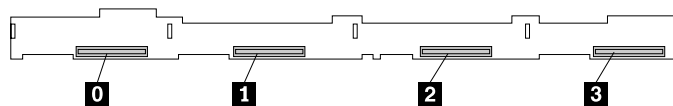

Figure 22. Front view

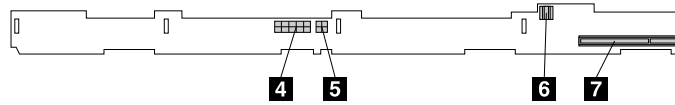

Figure 23. Rear view

**0 - 3 Slot 0-slot 3**

Used to connect 3.5-inch drives.

**4 10-pin power connector**

Used to connect to the front-backplane power connector on the system board to provide power to the backplane.

**5 Optical drive power connector**

Used to connect the power cable for the slim optical drive.

**6 Signal cable connector**

Used to connect the signal cable for the rear 2.5-inch drives or the M.2 storage module.

**7 AnyRAID adapter slot**

Used to connect to an AnyRAID adapter.

**Backplane for up to eight 2.5-inch drives**

The following illustrations show the slots and connectors on the backplane for up to eight 2.5-inch drives.

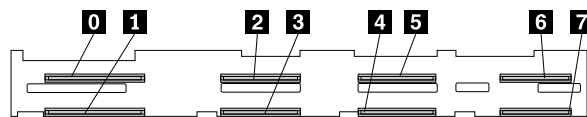

Figure 24. Front view

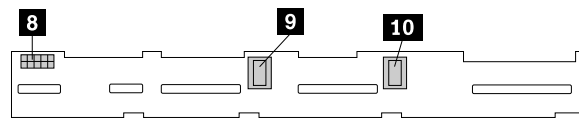

Figure 25. Rear view

**0 - 7 Slot 0-slot 7**

Used to connect 2.5-inch drives.

**8 10-pin power connector**

Used to connect to the backplane power connector on the system board to provide power to the backplane.

**9 Mini-SAS ports 4-7**

Used to connect to the mini-SAS connectors on a PCIe RAID adapter to support the hard disk drive 4 to hard disk drive 7.

## 10 Mini-SAS ports 0-3

Used to connect to the mini-SAS connectors on a PCIe RAID adapter to support the hard disk drive 0 to hard disk drive 3.

## Backplane for up to twelve 2.5-inch drives

The following illustrations show the slots and connectors on the backplane for up to twelve 2.5-inch drives.

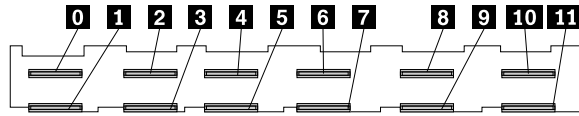

Figure 26. Front view

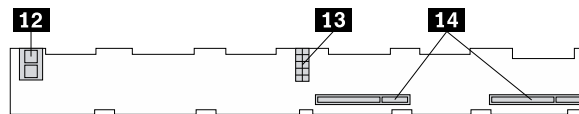

Figure 27. Rear view

### 0 - 11: Slot 0-slot 11

Used to connect 2.5-inch drives.

### 12 PCIe signal connectors

Used to connect the signal cable for the PCIe interposer card.

### 13 10-pin power connector

Used to connect to the front-backplane power connector on the system board to provide power to the backplane.

### 14 AnyRAID adapter slot (2)

Used to connect to an AnyRAID adapter.

## Rear backplane for up to two 2.5-inch drives

The following illustrations show the slots and connectors on the rear backplane for up to two 2.5-inch drives.

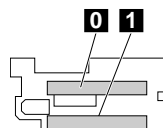

Figure 28. Front view of the rear backplane for up to two 2.5-inch drives



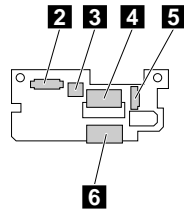

Figure 29. Rear view of the rear backplane for up to two 2.5-inch drives

**0 Slot 0**

**1 Slot 1**

Used to connect 2.5-inch drives.

**2 Drive sideband signals connector**

**4 Drive connector 0**

**6 Drive connector 1**

Used to connect to one of the following connectors:

- Rear 2.5-inch drive signal cable connector on the 3.5-inch backplane
- SATA connector on the Lenovo ThinkServer RAID 720ix AnyRAID Adapter
- SATA connector 1 (ports 4-7) on the system board

**3 4-pin power connector**

Used to connect to the rear-backplane power connector on the system board.

**5 Rear-backplane signal connector**

Used to connect to the rear-backplane signal connector on the system board.

## System board components

The following illustration shows the component locations on the system board.

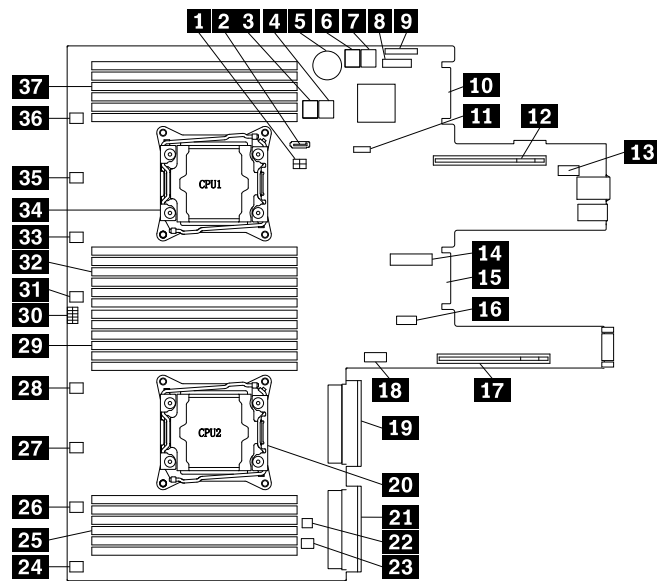

Figure 30. System board components

<b>1</b> Rear-backplane power connector	<b>2</b> SATA connector (optical drive)
<b>3</b> AnyRAID connector 1	<b>4</b> AnyRAID connector 0
<b>5</b> Coin-cell battery	<b>6</b> SATA connector 0 (ports 0-3)
<b>7</b> SATA connector 1 (ports 4-7)	<b>8</b> Front panel connector 2
<b>9</b> Front panel connector 1	<b>10</b> AnyFabric connector 2
<b>11</b> Rear-backplane signal connector	<b>12</b> Riser card assembly 1 slot
<b>13</b> Serial-port-module connector	<b>14</b> ThinkServer Trusted Platform Module connector
<b>15</b> AnyFabric connector 1	<b>16</b> SD module connector
<b>17</b> Riser card assembly 2 slot	<b>18</b> ThinkServer System Manager Premium module connector
<b>19</b> Power supply connector 2	<b>20</b> Microprocessor 2 socket
<b>21</b> Power supply connector 1	<b>22</b> RAID upgrade key connector
<b>23</b> Intrusion switch connector	<b>24</b> System fan 8 connector
<b>25</b> CPU2 memory slots (6)	<b>26</b> System fan 7 connector
<b>27</b> System fan 6 connector	<b>28</b> System fan 5 connector
<b>29</b> CPU2 memory slots (6)	<b>30</b> Front-backplane power connector
<b>31</b> System fan 4 connector	<b>32</b> CPU1 memory slots (6)
<b>33</b> System fan 3 connector	<b>34</b> Microprocessor 1 socket
<b>35</b> System fan 2 connector	<b>36</b> System fan 1 connector
<b>37</b> CPU1 memory slots (6)	

### **1** Rear-backplane power connector

Used to connect to the 4-pin power connector on the rear backplane.

## **2 SATA connector (optical drive)**

Used to connect the signal cable of the slim optical drive.

## **3 AnyRAID connector 1**

## **4 AnyRAID connector 0**

Used to connect to the PCIe connectors on the AnyRAID adapter.

## **5 Coin-cell battery**

Your server has a special type of memory that maintains the date, time, and configuration information for built-in features. The coin-cell battery keeps the information active when you turn off the server.

## **6 SATA connector 0 (ports 0-3)**

Used to connect to the SATA connector 0 (ports 0-3) on the ThinkServer RAID 110i AnyRAID Adapter.

## **7 SATA connector 1 (ports 4-7)**

Used to connect to the SATA connector 1 (ports 4-7) on the ThinkServer RAID 110i AnyRAID Adapter.

## **8 Front panel connector 2**

Used to connect to the front VGA and USB module.

## **9 Front panel connector 1**

Used to connect to the front panel board.

## **10 AnyFabric connector 2**

## **15 AnyFabric connector 1**

Used to connect the AnyFabric adapter.

## **11 Rear-backplane signal connector**

Used to connect the signal cable from either of the following hardware component:

- M.2 storage module (available on some models)
- Rear backplane for up to two 2.5-inch drives (available on some models)

## **12 Riser card assembly 1 slot**

## **17 Riser card assembly 2 slot**

Used to install the riser card assembly.

## **13 Serial-port-module connector**

Used to connect an optional serial port module.

## **14 ThinkServer Trusted Platform Module connector**

Used to connect a ThinkServer Trusted Platform Module (hereinafter referred to as the TPM), which is a security chip, to enhance server security. See “Installing or removing the ThinkServer Trusted Platform Module” on page 73.

#### **16 SD module connector**

Used to connect an SD module.

#### **18 ThinkServer System Manager Premium module connector**

Used to connect a ThinkServer System Manager Premium module to enable advanced remote management functions on your server.

#### **19 Redundant power supply connector 2**

#### **21 Redundant power supply connector 1**

Used to connect a redundant power supply.

#### **22 RAID upgrade key connector**

Used to connect a ThinkServer RAID 110i upgrade key.

#### **23 Intrusion switch connector**

Used to connect to an intrusion switch.

#### **25 29 32 37 Memory slots**

There are 24 memory slots on the system board. For more information, see “Memory module installation rules” on page 66.

#### **20 Microprocessor 2 socket**

#### **34 Microprocessor 1 socket**

For server models with two microprocessors, each of the microprocessor is secured in the microprocessor socket on the system board and a heat sink is installed above it to provide cooling. For server models with one microprocessor, the socket for the microprocessor 2 is protected by a microprocessor socket cover.

#### **24 26 27 28 31 33 35 36 System fan connectors**

Used to connect the cable of the corresponding system fan.

#### **30 Front backplane power connector**

Used to connect the power cable from the backplane.

## **System board switches**

The following illustration shows the switches on the system board of your server.

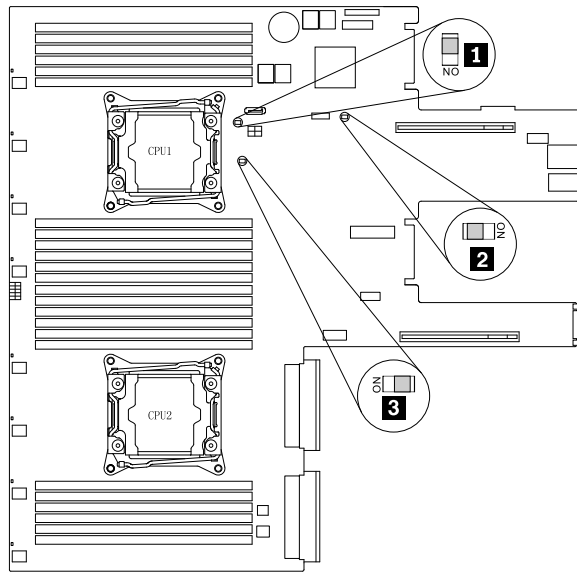

Figure 31. System board switches

Table 2. System board switches

<b>1</b> Clear password switch	<b>2</b> BIOS default settings switch
<b>3</b> BIOS recovery switch	

**Attention:** To set the switches, you need to remove the server cover to access the system board. Do not open your server or attempt any repair before reading and understanding “Read this first: safety information” on page v and “Guidelines” on page 59.

**1 Clear password switch** (Default setting: off)

Used to erase forgotten passwords, such as the BIOS passwords.

To clear passwords, do the following:

1. Remove all external media from the drives and turn off all attached devices and the server. Then, disconnect all power cords from electrical outlets and disconnect all cables that are connected to the server.
2. Prepare your server. See “Removing or extending the server from the rack cabinet” on page 61.
3. Remove the server cover. See “Removing the server cover” on page 61.
4. Locate the clear password switch **1** on the system board. Then, remove any parts and disconnect any cables that might impede your access to the switch.

**Note:** Do not remove the memory modules or microprocessors.

5. Move the switch from the default off position to the on position.
6. Reinstall any parts and reconnect any cables. Then, reinstall the server cover. See “Completing the parts replacement” on page 154.
7. Connect the server to an ac power source and wait for about five minutes for the BMC initialization. Then, turn on the server. The BIOS passwords are erased, including the administrator password and user password.
8. Repeat step 1 through step 3.
9. Move the switch back to the off position.

10. Reinstall any parts and reconnect any cables. Then, reinstall the server cover. See “Completing the parts replacement” on page 154.
11. Connect the server to an ac power source and turn on the server.
12. To set new passwords, see “Using passwords” on page 50.

#### **J BIOS default settings switch** (Default setting: off)

Used to turn the BIOS settings into the factory default settings.

To turn the BIOS settings into the factory-default settings, do the following:

1. Remove all external media from the drives and turn off all attached devices and the server. Then, disconnect all power cords from electrical outlets and disconnect all cables that are connected to the server.
2. Prepare your server. See “Removing or extending the server from the rack cabinet” on page 61.
3. Remove the server cover. See “Removing the server cover” on page 61.
4. Locate the BIOS default settings switch **J** on the system board. Then, remove any parts and disconnect any cables that might impede your access to the jumper.

**Note:** Do not remove the memory modules or microprocessors.

5. Move the switch from the default off position to the on position.
6. Reinstall any parts and reconnect any cables. Then, reinstall the server cover. See “Completing the parts replacement” on page 154.
7. Connect the server to an ac power source and wait for about five minutes for the BMC initialization. Then, turn on the server. The BIOS settings turn into the factory-default settings.
8. Repeat step 1 through step 3.
9. Move the switch back to the off position.
10. Reinstall any parts and reconnect any cables. Then, reinstall the server cover. See “Completing the parts replacement” on page 154.
11. Connect the server to an ac power source and turn on the server.

#### **K BIOS recovery switch** (Default setting: off)

Used to recover the BIOS if the power to your server is interrupted while the BIOS is being updated and your server cannot start correctly.

To recover the BIOS, see “Recovering from a BIOS update failure” on page 53.

## **System fan fault LEDs**

The following illustration shows the system fan fault LEDs on the system board.

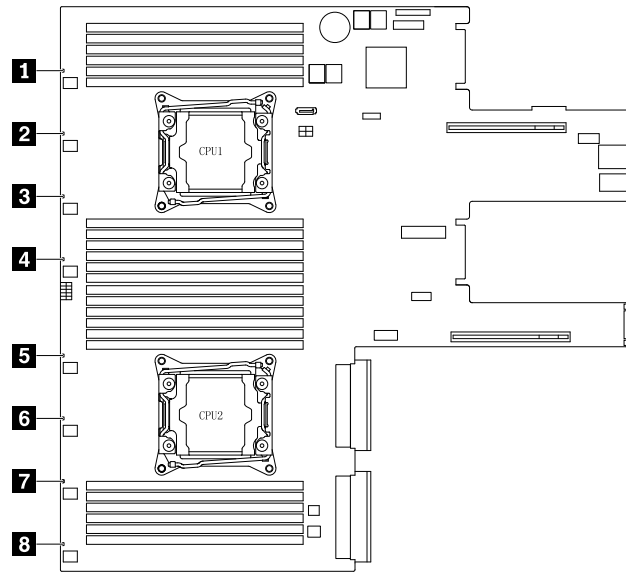

Figure 32. System fan fault LEDs

### 1 - 8 System fan fault LEDs 1 to 8

When a System fan fault LED on the system board is lit, it indicates that the corresponding system fan is operating too slowly or has failed. To solve the problem, you might need to reinstall or replace the system fan. See “Replacing a system fan” on page 142. If it is a system board problem, contact the Lenovo Customer Support Center.

## Hot-swap-drive status LEDs

Each hot-swap drive has two status LEDs on the front.

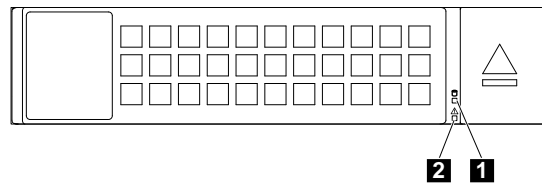

Figure 33. Hot-swap-drive status LEDs

1 Drive activity LED	2 Drive status LED	Description
Off	Off	The drive has failed or is not present.
On, green	Off	The drive is present but not in use.
Blinking, green	Off	The drive is active and data is being transferred.
On, green	Blinking rapidly (about four flashes per second), amber	The RAID controller is identifying the drive.

1 Drive activity LED	2 Drive status LED	Description
On, green	On, amber	<p>One of the following situations:</p> <ul style="list-style-type: none"> <li>The drive has failed. Replace the drive.</li> <li>The status of the drive is <b>Unconfigured Bad</b>. Replace the drive.</li> </ul> <p><b>Note:</b> If a drive in a RAID array is removed and then reinstalled while the server is on, the status of the drive will be identified as <b>Unconfigured Bad</b>. In this case, do not replace the drive. You can change the drive status into <b>Unconfigured Good</b> using the ThinkServer MegaRAID SAS Software.</p> <ul style="list-style-type: none"> <li>The status of the drive is <b>Offline</b>. You can change the drive status into <b>Online</b> using the ThinkServer MegaRAID SAS Software.</li> </ul> <p>For detailed information about using the ThinkServer MegaRAID SAS Software, refer to the <i>ThinkServer MegaRAID SAS Software User Guide</i>. You can obtain the most up-to-date documentation for your server from the Lenovo Web site at: <a href="http://www.lenovo.com/UserManuals">http://www.lenovo.com/UserManuals</a></p>
Blinking, green	Blinking slowly (about one flash per second), amber	The drive is being rebuilt.

## Power supply status LEDs

Each hot-swap power supply has three status LEDs.

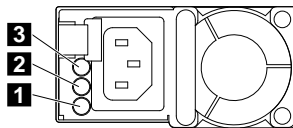

Figure 34. Power supply status LEDs

LED	Status	Description	Action
1 Input status LED	Off	The power supply is disconnected from the ac power source.	No action is needed.
	On, green	The power supply is connected to the ac power source.	No action is needed.
2 Output status LED	Off	The server is off or the power supply is not working normally.	Replace the power supply. See "Installing or replacing a hot-swap redundant power supply" on page 123.
	Blinking, green (about 1 flash every 2 seconds)	The power supply is in cold redundancy active mode.	No action is needed.
	Blinking, green (about 2 flashes per second)	The power supply is in cold redundancy sleep mode.	No action is needed.
	On, green	The server is on and the power supply is working normally.	No action is needed.
3 Fault LED	Off	The power supply is working normally.	No action is needed.



LED	Status	Description	Action
	On, amber	The power supply has failed.	Replace the power supply. See “Installing or replacing a hot-swap redundant power supply” on page 123.

## Connecting cables

To connect the signal cables from the installed hardware components, refer to the related information in the following topics:

- “System board components” on page 35
- “RAID adapter” on page 27
- “Backplane” on page 31
- “Installing the M.2 storage module” on page 85



---

## Chapter 4. Turning on and turning off the server

This chapter provides information about turning on and turning off the server.

---

### Turning on the server

The server can be turned on in one of the following ways:

- After you finish unpacking and setting up the server, connect it to an ac power source. Press the power button on the front panel to turn on the server. See “Front panel” on page 19. The server needs about 30 seconds for the ThinkServer System Manager (TSM, also known as BMC) to initialize whenever you connect the server to an ac power source. If you press the power button on the front panel during this period, the server will not start immediately; it will start after the TSM initialization finishes.
  - When the Wake on LAN feature is enabled on the server that is connected to an ac power source and a LAN, a network administrator can remotely turn on or wake up the server from a management console using remote network management software.
  - You also can use the related TSM feature to remotely turn on the server through the management LAN.
- 

### Turning off the server

#### CAUTION:

**The power control button on the device and the power switch on the power supply do not turn off the electrical current supplied to the device. The device also might have more than one power cord. To remove all electrical current from the device, ensure that all power cords are disconnected from the power source.**

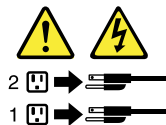

The server can be turned off in one of the following ways:

- Turn off the server from the operating system if your operating system supports this feature. After an orderly shutdown of the operating system, the server will turn off automatically. For instructions on how to shut down your specific operating system, refer to the related documentation or help system for the operating system.
- Press the power switch on the front panel to start an orderly shutdown of the operating system and turn off the server, if your operating system supports this feature.
- If your server stops responding and you cannot turn it off, press and hold the power switch on the front panel for four seconds or more. If you still cannot turn off the server, disconnect all power cords from the server.
- If the server is connected to a LAN, a network administrator can remotely turn off the server from a management console using remote network management software.
- You also can use the related TSM feature to remotely turn off the server through the management LAN.
- The server might be turned off as an automatic response to a critical system failure.

#### Notes:

- When you turn off the server and leave it connected to an ac power source, the server also can respond to a remote request to turn on the server. To remove all power from the server, you must disconnect the server from the ac power source.
- For information about your specific operating system, refer to the related documentation or help system for the operating system.

---

## Chapter 5. Configuring the server

This chapter provides the following information to help you configure the server:

- “Using the Setup Utility program” on page 47
- “Configuring RAID” on page 54
- “Updating the firmware” on page 57

---

### Using the Setup Utility program

This topic provides information about using the Setup Utility program.

The Setup Utility program is part of the server firmware. You can use the Setup Utility program to view and change the configuration settings of your server, regardless of which operating system you are using. However, the operating system settings might override any similar settings in the Setup Utility program.

### Starting the Setup Utility program

This topic provides instructions on how to start the Setup Utility program.

To start the Setup Utility program, do the following:

1. Connect the server to an ac power source and press the power switch on the front panel to turn on the server. See “Turning on the server” on page 45.
2. Press the F1 key as soon as you see the logo screen. Then, wait for several seconds, and the Setup Utility program opens. If you have set a password, type the correct password to enter the Setup Utility program. For password information, see “Using passwords” on page 50.

### Viewing information in the Setup Utility program

The Setup Utility program menu lists various items about the system configuration. Select a desired item to view information or change settings.

When working with the Setup Utility program, you must use the keyboard. The keys used to perform various tasks are displayed on the right bottom pane of each screen. You also can press the F1 key for general help about the keys. For most items, the corresponding help message is displayed on the right top pane of the screen when the item is selected. If the item has submenus, you can display the submenus by pressing Enter.

### Setup Utility program interface

Depending on the BIOS version of your server, some menu or item information might differ slightly from the information in this topic.

#### Notes:

- The default settings already are optimized for you. Use the default value for any item you are not familiar with. Do not change the value of unfamiliar items to avoid unexpected problems. If you consider changing the server configuration, proceed with extreme caution. Setting the configuration incorrectly might cause unexpected results. If you cannot turn on the server because of incorrect BIOS settings, use the BIOS default settings jumper to restore the BIOS settings to the factory default settings. See “System board switches” on page 38.

- If you have changed any hardware in the server, you might need to upgrade the BIOS and the TSM firmware.

The Setup Utility program main interface consists of the following menus:

- “System Information menu” on page 48
- “Advanced Settings menu” on page 48
- “System Security menu” on page 49
- “TSM Settings menu” on page 49
- “Boot Manager menu” on page 49
- “Save & Exit menu” on page 49

Lenovo provides the BIOS update utility on the Lenovo Support Web site. You can download the BIOS update utility to update the BIOS. See “Updating or recovering the BIOS” on page 53.

If the power to your server is interrupted while the BIOS is being updated and your server cannot start correctly, the BIOS will recover to the previous version automatically. The recovery process lasts about 20 minutes. You also can use the BIOS recovery jumper to recover from a BIOS update failure. See “System board switches” on page 38.

## System Information menu

After entering the Setup Utility program, you can see the **System Information** menu, which lists basic information about the BIOS, microprocessor type, memory, system date and time, and so on.

To set the system date and time on the **System Information** menu, see “Setting the system date and time” on page 50.

## Advanced Settings menu

You can view or change various server component settings on the **Advanced Settings** menu in the Setup Utility program. The **Advanced Settings** menu contains various configuration submenus and items. On each submenu, press Enter to show selectable options and select a desired option by using the up and down arrow keys or type desired values from the keyboard. Some items are displayed on the menu only if the server supports the corresponding features.

### Notes:

- **Enabled** means that the function is configured.
- **Disabled** means that the function is not configured.

The **Advanced Settings** menu contains the following submenus. For more information, enter the corresponding submenu and refer to the instructions on the screen.

- **Processor Settings:** View information about the installed microprocessors and set microprocessor configuration parameters.
- **Memory Settings:** View information about the installed memory modules and set memory configuration parameters.
- **Advanced Power Settings:** View and set power and performance parameters.
- **PCI/PCIE Settings:** View and set PCI or PCIe configuration parameters.
- **SATA Settings:** Set onboard SATA parameters.
- **USB Settings:** View and set USB configuration parameters, such as enabling or disabling USB devices.
- **Serial Settings:** View and set configuration parameters for the serial connector.

- **Wakeup Settings:** View and configure the wakeup timing and set the power state after a power failure.
- **Miscellaneous Settings:** View and configure some miscellaneous items, such as the NumLock key on the keyboard and the boot status code.

## System Security menu

You can set passwords and configure the TPM function on the **System Security** menu in the Setup Utility program. For each menu item, press Enter to show selectable options and select a desired option by using the up and down arrow keys or type desired values from the keyboard. Some items are displayed on the menu only if the server supports the corresponding features.

### Notes:

- **Enabled** means that the function is configured.
- **Disabled** means that the function is not configured.

The **System Security** menu contains the following items:

- **Administrator Password:** Set an administrator password to protect against unauthorized access to your server. See “Using passwords” on page 50.
- **User Password:** Set a user password to protect against unauthorized access to your server. See “Using passwords” on page 50.
- **Secure Boot:** Set secure boot parameters.
- **TPM/TCM:** Configure the TPM function if your server has a TPM installed in the TPM connector on the system board. See “Configuring the TPM function” on page 52.

## TSM Settings menu

You can view or change event log and BMC settings on the **TSM Settings** menu in the Setup Utility program. On each submenu, press Enter to view the information or show selectable options and select a desired option by using the up and down arrow keys. Some items are displayed on the menu only if the server supports the corresponding features.

The **TSM Settings** menu contains the following submenus. For more information, enter the corresponding submenu and refer to the instructions on the screen.

- **TSM Network Settings:** Set BMC management network configuration parameters.
- **User Account Settings:** Set BMC user account parameters.

## Boot Manager menu

The **Boot Manager** menu in the Setup Utility program lists all the bootable devices installed in your server and the listed items vary depending on your server configuration.

The **Boot Sequence** submenu in the **Boot Manager** menu provides an interface to help you view or change the server startup options, including the startup sequence and boot priority for various devices. Changes in the startup options take effect when the server restarts. The startup sequence specifies the order in which the server checks devices to find a boot record. The server starts from the first boot record that it finds. For example, you can define a startup sequence that checks a disc in the optical drive, then checks the internal storage drive, and then checks a network device. For information about setting the startup sequence or selecting a startup device, see “Selecting a startup device” on page 51.

## Save & Exit menu

After you finish viewing or changing settings in the Setup Utility program, you can choose a desired action from the **Save & Exit** menu to save changes, discard changes, or load default values, and exit the program. Press Enter to select the item on the **Save & Exit** menu, and then select **Yes** when prompted to confirm the

action. For information about exiting the Setup Utility program, see “Exiting the Setup Utility program” on page 52.

The **Save & Exit** menu contains the following items:

- **Save Changes and Reset:** Save changes and then continue with further configuration in the Setup Utility program.
- **Discard Changes and Exit:** Discard changes, load previous values, and then exit the Setup Utility program.
- **Load Optimized Defaults:** Return to the optimized default settings.
- **Save as User Defaults:** Save the current settings as user default values.
- **Restore User Defaults:** Restore the user default values for all the items.
- **Pure UEFI OS Optimized Defaults:** Enable or disable optimized default settings for the pure UEFI operating system.

## Setting the system date and time

To set the system date and time in the Setup Utility program, do the following:

1. Start the Setup Utility program. See “Starting the Setup Utility program” on page 47.
2. On the **System Information** menu, select **System Date** or **System Time**.
3. Use the Tab key to switch between data elements and type the numbers from the keyboard to set the system date and time.
4. Press F10 to save settings and exit the Setup Utility program.

## Using passwords

By using the Setup Utility program, you can set a password to prevent unauthorized access to your server.

You do not have to set a password to use your server. However, using a password improves computing security. If you decide to set a password, read the following topics.

### Setup Utility program password types

The following types of passwords are available in the Setup Utility program:

- **Administrator password**

Setting an administrator password deters unauthorized users from changing configuration settings. If you are responsible for maintaining the configuration settings of several computers, you might want to set an administrator password. When an administrator password is set, you are prompted to type a valid password each time you try to access the Setup Utility program. The Setup Utility program cannot be accessed until a valid password is typed in.

- **User password**

When a user password is set, you are prompted to type a valid password each time the server turns on. You can not log in to any operating system until a valid password is typed in.

**Note:** If both the administrator password and user password are set, you can type either password to use the server. However, you must use your administrator password to change any configuration settings.

### Password considerations

For security reasons, it is recommended to use a strong password that cannot be easily compromised.

#### Notes:



- The Setup Utility program passwords are not case sensitive.
- The server supports Setup Utility program passwords that consist of three to 32 characters.

To set a strong password, use the following guidelines:

- Have at least eight characters in length
- Contain at least one alphabetic character and one numeric character
- Not be your name or your user name
- Not be a common word or a common name
- Be significantly different from your previous passwords

Besides the alphabetic characters (a-z) and numeric characters (0-9), the server also supports characters typed using special keys on the keyboard for a password. Refer to the help message on the screen when setting a password to determine the valid special characters.

### Setting, changing, or deleting a password

To set, change, or delete a password in the Setup Utility program, do the following:

1. Start the Setup Utility program. See “Starting the Setup Utility program” on page 47.
2. On the **System Security** menu, select **Administrator Password** to set an administrator password or select **User Password** to set a user password.
3. See “Password considerations” on page 50. Then, follow the instructions on the screen to set or change a password.
4. If you want to delete a password, type your current password. Press Enter when you are prompted to type a new password. Then, press Enter to confirm the new password. The previous password will be cleared.

**Note:** For security reasons, it is recommended that you always set a password for your server.

5. Press F10 to save settings and exit the Setup Utility program.

If you have forgotten the password, you can use the clear password jumper on the system board to erase the password. See “System board switches” on page 38. Then, set a new password for the server.

### Selecting a startup device

If your server does not start up from a desired device such as the disc or storage drive as expected, do one of the following to select the startup device you want.

**Note:** Not all discs, storage drives, or other removable devices are bootable.

- To select a temporary startup device, do the following:

**Note:** Selecting a startup device using the following method does not permanently change the startup sequence.

1. Turn on or restart your server.
  2. When you see the logo screen, press F11 if your server is connected to a network and you want to start up the server from the network. Otherwise, press F12 to display the boot menu. The boot device selection window opens.
  3. In the boot device selection window, use the up and down arrow keys on the keyboard to switch between the selections. Press Enter to select the device of your choice. Then, the server will start up from the selected device.
- To view or permanently change the configured startup device sequence, do the following:

1. Start the Setup Utility program. See “Starting the Setup Utility program” on page 47.
2. On the **Boot Sequence** submenu under the **Boot Manager** menu, follow the instructions on the screen to set the startup device for **Boot Option #1** to **Boot Option #5** depending on your needs. You also can set the boot priority for various devices. See “Boot Manager menu” on page 49.
3. Press F10 to save settings and exit the Setup Utility program. The server will follow the startup device sequence you have set each time you turn on the server.

## Configuring the TPM function

The TPM works as a hardware security solution to help you to encrypt data and protect the server. The TPM function is only available when there is a TPM installed in your server. See “Installing the TPM” on page 73. You can purchase a TPM from the Lenovo Web site at:

<http://lenovoquickpick.com/usa/home/thinkserver/rack-and-tower-server>

After installing a TPM, check if the TPM function is enabled in the Setup Utility program.

To enable the TPM function in the Setup Utility program, do the following:

1. Start the Setup Utility program. See “Starting the Setup Utility program” on page 47.
2. On the **System Security** menu, select **TPM Settings → TPM Support**.
3. Do one of the following:
  - If **TPM Support** is set to **Enabled**, the **TPM Security Feature** item is displayed. Set **TPM Security Feature** to **Activate**.
  - If **TPM Support** is set to **Disabled**, do the following:
    - a. Set **TPM Support** to **Enabled** and press F10 to save settings and exit the Setup Utility program. The server will restart.
    - b. Start the Setup Utility program. On the **System Security** menu, select **TPM Settings**. Then, set **TPM Security Feature** to **Activate**.
4. Press F10 to save settings and exit the Setup Utility program. The server will restart to enable the TPM function.

## Setting an Ethernet connector for system management

The RJ-45 Ethernet connector on the rear of the server is for system management by default. You also can use the Ethernet connector on the installed AnyFabric adapter for system management.

To set the Ethernet connector for system management, do the following:

1. Start the Setup Utility program. See “Starting the Setup Utility program” on page 47.
2. On the **TSM Settings** menu, select **TSM Network Settings → TSM NIC Selection**.
3. Do one of the following:
  - To use the RJ-45 Ethernet connector for system management, select **Dedicated Port**.
  - To use the Ethernet connector on the installed AnyFabric adapter for system management, select **Shared AnyFabric Port**.
4. Press F10 to save settings and exit the Setup Utility program.

## Exiting the Setup Utility program

After you finish viewing or changing settings, press Esc to return to the Setup Utility program main interface. If you are on a nested submenu, press Esc repeatedly until you reach the main interface. Then, you can do one of the following to exit the Setup Utility program:

- If you want to save the new settings and exit the Setup Utility program, press F10 or select **Save & Exit → Save Changes and Reset**. Otherwise, your changes will not be saved.
- If you do not want to save the new settings, select **Save & Exit → Discard Changes and Exit**.
- If you want to return to the default settings, press F9 or select **Save & Exit → Load Optimized Defaults**.

For more information about the **Save & Exit** menu in the Setup Utility program, see “Save & Exit menu” on page 49.

## Updating or recovering the BIOS

This topic provides instructions on how to update the BIOS and how to recover from a POST and BIOS update failure.

Lenovo might make changes and enhancements to the BIOS and TSM firmware. When updates are released, they are available for download on the Lenovo Web site at <http://www.lenovo.com/drivers>. You can update the server firmware by downloading an update package and following the instructions on the Web page.

### Updating (flashing) the BIOS

This topic provides instructions on how to update (flash) the BIOS.

#### Notes:

- Update the BIOS on your server only if the newer BIOS version specifically solves a problem you have. We do not recommend BIOS updates for servers that do not need them. You can view the updated information for the new BIOS version in the installation instructions for the BIOS update utility program.
- Downgrading the BIOS to an earlier version is not recommended and might not be supported. An earlier BIOS version might not support the latest system configurations.
- If the power to your server is interrupted while the POST and BIOS are being updated, your server might not restart correctly. Ensure that you perform the BIOS update procedure in an environment with a steady power supply. Besides, ensure that your server can restart successfully without encountering hardware problems.
- After updating the BIOS firmware, all of your previous BIOS settings will be automatically restored. Check and reconfigure the BIOS settings for your specific needs.

To update (flash) the BIOS, do the following:

1. Go to <http://www.lenovo.com/drivers> and follow the instructions on the Web page to locate the BIOS update package.
2. Download the BIOS update package and the TXT file that contains installation instructions.
3. Print the TXT file and follow the instructions to update (flash) the BIOS.
4. Check and reconfigure the BIOS settings for your specific needs based on your note or refer to “Using the Setup Utility program” on page 47 after the BIOS update process is completed.

### Recovering from a BIOS update failure

If the power to your server is interrupted while the BIOS is being updated, your server might not restart correctly. If this happens, perform the following procedures to recover from the BIOS update failure.

**Note:** If the operating system of your server is installed under EFI mode, you must reinstall the operating system after recovering the BIOS.

To recover from a BIOS update failure, do one of the following:

- **Using the automatic recovery feature**

1. Reconnect the server to an ac power source.
2. After the system health LED turns off, press the power button to turn on the server. The server is turned on and then turned off automatically. Then, the recovery process starts. Wait for about 20 minutes for the TSM to recover the BIOS. To prevent permanent damage, **DO NOT TURN OFF THE SERVER** during the recovery process. When the recovery process is completed, the server turns on automatically.
3. Check and configure the BIOS settings for your specific needs. See “Using the Setup Utility program” on page 47.

- **Using the BIOS recovery switch**

1. Remove all external media from the drives and turn off all attached devices and the server. Then, disconnect all power cords from electrical outlets and disconnect all cables that are connected to the server.
2. Prepare your server. See “Removing or extending the server from the rack cabinet” on page 61.
3. Remove the server cover. See “Removing the server cover” on page 61.
4. Locate the BIOS recovery switch on the system board. See “System board switches” on page 38. Then, remove any parts and disconnect any cables that might impede your access to the jumper.

**Note:** Do not remove the memory modules or microprocessors.

5. Move the BIOS recovery switch from the default off position to the on position.
6. Reinstall any parts and reconnect any cables. Then, reinstall the server cover. See “Completing the parts replacement” on page 154.
7. Connect the server to an ac power source. The server turns on and then turns off automatically.
8. Wait for about 20 minutes for the TSM to recover the BIOS. To prevent permanent damage, **DO NOT TURN OFF THE SERVER** during the recovery process. When the BIOS recovery process is completed, the server turns on automatically.
9. Ensure that the Setup Utility program starts normally. See “Starting the Setup Utility program” on page 47. Then, disconnect the server from the ac power source.
10. Repeat step 1 through step 3.
11. Move the BIOS recovery switch back to the off position.
12. Reinstall any parts and reconnect any cables. Then, reinstall the server cover. See “Completing the parts replacement” on page 154.
13. Connect the server to an ac power source and turn on the server. Check and configure the BIOS settings for your specific needs. See “Using the Setup Utility program” on page 47.

**Note:** If you cannot recover the BIOS after using the instructions in this topic, the BIOS read-only memory (ROM) might be damaged. You must replace the system board. Contact the Lenovo Customer Support Center.

---

## Configuring RAID

This topic provides information about RAID and the utility programs that are available for you to configure RAID.

This topic contains the following information:

- “About RAID” on page 55
- “Configuring RAID using the Lenovo ThinkServer Deployment Manager program” on page 56
- “Configuring the advanced SATA or SAS hardware RAID” on page 56

## About RAID

RAID, an acronym for Redundant Array of Independent Disks, is a technology that provides increased storage functions and reliability through redundancy. This is achieved by combining multiple hard disk drives into a logical unit, where data is distributed across the drives in one of several ways called RAID levels.

When a group of independent physical hard disk drives are set up to use RAID technology, they are in a RAID array. This array distributes data across multiple hard disk drives, but the array appears to the host server as one single storage unit. Creating and using RAID arrays provides high performance, such as the expedited I/O performance, because several drives can be accessed simultaneously.

RAID drive groups also improve data storage reliability and fault tolerance compared with single-drive storage systems. Data loss resulting from a drive failure can be prevented by reconstructing missing data from the remaining drives.

The following list describes some of the most commonly used RAID levels:

- **RAID 0:** block-level striping without parity or mirroring  
Simple stripe sets are normally referred to as RAID 0. RAID 0 uses striping to provide high data throughput, especially for large files in an environment that does not require fault tolerance. RAID 0 has no redundancy and it provides improved performance and additional storage without fault tolerance. Any drive failure destroys the array and the likelihood of failure increases with more drives in the array. RAID 0 does not implement error checking, so any error is uncorrectable. More drives in the array means higher bandwidth, but greater risk of data loss.  
RAID 0 requires a minimum number of one hard disk drive.
- **RAID 1:** mirroring without parity or striping  
RAID 1 uses mirroring so that data written to one drive is simultaneously written to another drive. This is good for small databases or other applications that require small capacity but complete data redundancy. RAID 1 provides fault tolerance from disk errors or failures and continues to operate as long as at least one drive in the mirrored set is functioning. With appropriate operating system support, there can be increased read performance and only a minimal write performance reduction.  
RAID 1 requires a minimum number of two hard disk drives.
- **RAID 5:** block-level striping with distributed parity  
RAID 5 uses disk striping and parity data across all drives (distributed parity) to provide high data throughput, especially for small random access. RAID 5 distributes parity along with the data and requires all drives but one to be present to operate; drive failure requires replacement, but the array is not destroyed by a single drive failure. Upon drive failure, any subsequent read operations can be calculated from the distributed parity so that the drive failure is masked from the end user. The array will have data loss in the event of a second drive failure and is vulnerable until the data that was on the failing drive is rebuilt onto a replacement drive. A single drive failure in the set will result in reduced performance of the entire set until the failing drive has been replaced and rebuilt.  
RAID 5 requires a minimum number of three hard disk drives.
- **RAID 6:** block-level striping with distributed parity  
RAID 6 uses distributed parity, with two independent parity blocks per stripe, and disk striping. A RAID 6 virtual drive can survive the loss of any two drives without losing data. A RAID 6 drive group is similar to a RAID 5 drive group. Blocks of data and parity information are written across all drives. The parity information is used to recover the data if one or two drives fail in the drive group.  
RAID 6 requires a minimum number of three hard disk drives.
- **RAID 10:** a combination of RAID 0 and RAID 1  
RAID 10 consists of striped data across mirrored spans. A RAID 10 drive group is a spanned drive group that creates a striped set from a series of mirrored drives. RAID 10 allows a maximum of eight spans. You

must use an even number of drives in each RAID virtual drive in the span. The RAID 1 virtual drives must have the same stripe size. RAID 10 provides high data throughput and complete data redundancy but uses a larger number of spans.

RAID 10 requires a minimum number of four hard disk drives and also requires an even number of drives, for example, six hard disk drives or eight hard disk drives.

- **RAID 50:** a combination of RAID 0 and RAID 5

RAID 50 uses distributed parity and disk striping. A RAID 50 drive group is a spanned drive group in which data is striped across multiple RAID 5 drive groups. RAID 50 works best with data that requires high reliability, high request rates, high data transfers, and medium-to-large capacity.

**Note:** Having virtual drives of different RAID levels, such as RAID 0 and RAID 5, in the same drive group is not allowed. For example, if an existing RAID 5 virtual drive is created out of partial space in an array, the next virtual drive in the array has to be RAID 5 only.

RAID 50 requires a minimum number of six hard disk drives.

- **RAID 60:** a combination of RAID 0 and RAID 6

RAID 60 uses distributed parity, with two independent parity blocks per stripe in each RAID set, and disk striping. A RAID 60 virtual drive can survive the loss of two drives in each of the RAID 6 sets without losing data. RAID 60 works best with data that requires high reliability, high request rates, high data transfers, and medium-to-large capacity.

RAID 60 requires a minimum number of six hard disk drives.

For detailed information about RAID, refer to “Introduction to RAID” in the *MegaRAID SAS Software User Guide*. This guide is available on the Lenovo Support Web site at: <http://www.lenovo.com/support>

## Configuring RAID using the Lenovo ThinkServer Deployment Manager program

Deployment Manager simplifies the process of configuring supported RAID. The help system for the program can be accessed directly from the program interface.

Deployment Manager has the following features for RAID configuration:

- For use with all supported RAID controllers
- Automatically detects hardware and lists all supported RAID configurations
- Configures one or more disk arrays per controller depending on the number of drives attached to the controller and the RAID level selected
- Supports hot-spare drives
- Creates a RAID response file that can be used to configure RAID controllers on similarly configured Lenovo servers

See “Lenovo ThinkServer Deployment Manager” on page 13 and view the help system from the main interface of the program.

## Configuring the advanced SATA or SAS hardware RAID

Your server comes with an AnyRAID adapter to provide advanced SATA or SAS hardware RAID functions.

**Note:** Depending on the operating system, the total drive capacity of the primary RAID might be limited to 2 TB.

You can use the following programs or tools to configure the advanced SATA or SAS hardware RAID.

- MegaRAID Human Interface Infrastructure (HII) configuration utility

This utility enables you to configure RAID independently of the operating system. To display the HII configuration utility interface, start the server and press the F1 key as soon as you see the logo screen to enter the Setup Utility program. Then, select **Boot Manager → Adapters and UEFI Drivers**.

- MegaRAID Storage Manager program

This program provides graphical user interface (GUI) for you to create and manage storage configurations in an operating system environment.

- Storage Command Line Tool (StorCLI)

This is a command-line management tool that is used to configure RAID in an operating system environment.

To download the MegaRAID Storage Manager program and StorCLI, go to <http://www.lenovo.com/drivers> and follow the instructions on the Web page.

For more information about how to configure and manage the advanced SATA or SAS hardware RAID, refer to the *MegaRAID SAS Software User Guide*. This document also is available on the Lenovo Web site at: <http://www.lenovo.com/support>

---

## Updating the firmware

When you replace a device in the server, you might have to either update the server with the latest version of the firmware that is stored in memory on the device or reflash the BIOS, the TSM firmware, and the FRU/SDR.

To update the firmware, do one of the following:

- Go to <http://www.lenovo.com/drivers> and follow the instructions on the Web page to check for the latest level of firmware, such as the BIOS updates and device drivers.
- Use the Lenovo ThinkServer Deployment Manager program. See “Lenovo ThinkServer Deployment Manager” on page 13.





---

## Chapter 6. Replacing hardware

This chapter provides instructions on how to replace hardware for your server.

This chapter contains the following items:

- “Guidelines” on page 59
- “Removing the server cover” on page 61
- “Installing, removing, or replacing hardware” on page 62
- “Completing the parts replacement” on page 154

For a list of the ThinkServer options, go to:

<http://lenovoquickpick.com/usa/home/thinkserver/rack-and-tower-server>

---

### Guidelines

This topic provides some guidelines that you should read and understand before using your server.

### Precautions

Before you use the server, ensure that you read and understand the following precautions:

- Before using the product, ensure that you read and understand the multilingual safety instructions and the Lenovo Limited Warranty (LLW) on the Lenovo Web site at <https://support.lenovo.com/documents/LNVO-DOCS>. Reading and understanding the safety instructions reduces the risk of personal injury and damage to your product.
- When you install your new server, take the opportunity to download and apply the most recent firmware updates. This step will help to ensure that any known issues are addressed and that your server is ready to function at maximum levels of performance. To download firmware updates for your server, go to <http://www.lenovo.com/drivers>, and then follow the instructions on the Web page. See “Updating the firmware” on page 57 for more information.
- Before you install optional hardware devices, ensure that the server is working correctly. If the server is not working correctly, see Chapter 7 “Troubleshooting and diagnostics” on page 157 to do basic troubleshooting. If the problem cannot be solved, see Chapter 8 “Getting information, help, and service” on page 163.
- Observe good housekeeping in the area where you are working. Put removed covers and other parts in a safe place.
- If you must turn on the server while the server cover is removed, ensure that no one is near the server and that no tools or other objects have been left inside the server.
- Do not attempt to lift an object that you think is too heavy for you. If you have to lift a heavy object, observe the following precautions:
  - Ensure that you can stand safely without slipping.
  - Distribute the weight of the object equally between your feet.
  - Use a slow lifting force. Never move suddenly or twist when you lift a heavy object.
  - To avoid straining the muscles in your back, lift by standing or by pushing up with your leg muscles.
- Ensure that you have an adequate number of properly grounded electrical outlets for the server, monitor, and other devices.
- Back up all important data before you make changes to drives.

- Have a small flat-blade screwdriver available.
- You do not have to turn off the server to install or replace a hot-swap redundant power supply, hot-swap hard disk drives, hot-swap solid-state drives, or hot-plug USB devices. However, you must turn off the server before performing any steps that involve installing, removing, or replacing adapter cables or non-hot-swap devices or components.
- To view the LEDs on the system board and internal components, leave the server connected to power.
- When you are finished working on the server, reinstall all safety shields, guards, labels, and ground wires.

## Handling static-sensitive devices

**Attention:** Do not open the static-protective package that contains the new part until the defective part has been removed from the server and you are ready to install the new part. Static electricity, although harmless to you, can seriously damage server components and parts.

When you handle server parts and components, take these precautions to avoid static-electricity damage:

- Limit your movement. Movement can cause static electricity to build up around you.
- The use of a grounding system is recommended. For example, it is recommended to wear an electrostatic discharge (ESD) wrist strap, if one is available. Ensure that you work in an ESD-safe area.
- Always carefully handle the parts and other components (such as PCI cards, memory modules, system boards, and microprocessors) by edges or frame. Do not touch solder joints, pins, or exposed circuitry.
- Do not leave the device where others can handle and possibly damage the device.
- Before you replace a new part, touch the static-protective package containing the new part to an unpainted metal part of the server for at least two seconds. This reduces static electricity from the package and your body.
- Remove the new part from the static-protective package and directly install it in the server without placing it on any other surface. If it is hard for you to do this in your specific situation, place the static-protective package of the new part on a smooth, level surface, and then place the new part on the static-protective package.
- Do not place the part on the server cover or other metal surface.
- Take additional care when handling devices during cold weather. Heating reduces indoor humidity and increases static electricity.

## System reliability guidelines

To help ensure proper cooling and system reliability, strictly follow these guidelines:

- Each of the drive bays has a drive or a dummy tray installed; or there is an electromagnetic interface (EMI) protective panel or EMI shield installed to protect the drive cage.
- If the server supports hot-swap redundant power supplies, each of the power supply bay has a redundant power supply installed, or one bay has a redundant power supply installed while the other bay is covered by a shield.
- Leave adequate space around the server to ensure that the server cooling system works well. Leave approximately 50 mm (2 inches) of open space around the front and rear of the server. Do not place objects in front of the fans. For proper cooling and airflow, install the server cover before you turn on the server. Operating the server with the server cover removed might damage server components.
- Properly route the cables. For some options, such as PCI cards, follow the cabling instructions that come with the options in addition to the instructions in this manual.
- When replacing a hot-swap drive, install the new hot-swap drive as soon as possible.

- If your server has air ducts or air baffles, do not remove them while the server is running. Operating the server without the air ducts or air baffles might cause the microprocessor(s) to overheat.
- For servers that support up to two microprocessors, ensure that the second microprocessor socket always contains a microprocessor or is protected by a microprocessor socket cover.

## Working inside the server with the power on

**Attention:** Static electricity that is released to internal server components when the server is turned on might cause the server to halt, which might result in the loss of data. To avoid this potential problem, always use an ESD wrist strap or other grounding system when you work inside the server with the power on.

The server supports hot-swap devices and is designed to operate safely while it is turned on and the cover is removed. Follow these guidelines when you work inside the server with the power on:

- Avoid wearing loose-fitting clothing on your forearms. Button long-sleeved shirts before working inside the server; do not wear cuff links while you are working inside the server.
- Do not allow your necktie or scarf to hang inside the server.
- Remove jewelry, such as bracelets, necklaces, rings, and loose-fitting wrist watches.
- Remove items from your shirt pocket, such as pens and pencils. These items might fall into the server as you lean over it.
- Avoid dropping any metallic objects into the server, such as paper clips, hairpins, and screws.

---

## Removing or extending the server from the rack cabinet

If the server is installed in a rack cabinet, remove or extend the server from the rack cabinet before installing or replacing hardware. Depending on the rail type, do one of the following:

- If the server is installed in a rack cabinet using static rails, remove the server from the rack cabinet and place it on a flat, clean, and static-protective surface. See the *Rack Installation Instructions* that comes with the server.
- If the server is installed in a rack cabinet using slide rails, press the rack handles to extend the server from the rack cabinet. However, if the working environment, cabling configuration, or the server location in the rack cabinet creates awkward conditions, remove the server from the rack cabinet. See the *Rack Installation Instructions* that comes with the server.

---

## Removing the server cover

**Attention:** Do not open your server or attempt any repair before reading and understanding “Read this first: safety information” on page v and “Guidelines” on page 59.

Before you begin, print all the related instructions or ensure that you can view the PDF version on another computer for reference.

**Note:** Depending on the model, your server might look slightly different from the illustrations in this topic.

To remove the server cover, do the following:

1. Remove all external media from the drives and turn off all attached devices and the server. Then, disconnect all power cords from electrical outlets.
2. Disconnect the power cords, Input/Output (I/O) cables, and all other cables that are connected to the server.
3. Prepare your server. See “Removing or extending the server from the rack cabinet” on page 61.

4. Do the following to remove the server cover:
  - a. Use a screw driver to unscrew the cover lock to the open position as shown.
  - b. Fully open the cover latch.
  - c. Slide the server cover to the rear until it is disengaged from the chassis. Then, lift the server cover off the chassis and place the server cover on a flat clean surface.

**Note:** It is recommended that you wait several minutes to let the server cool before removing the server cover.

**Attention:** Handle the server cover carefully. Dropping the server cover with the cover latch open might damage the cover latch.

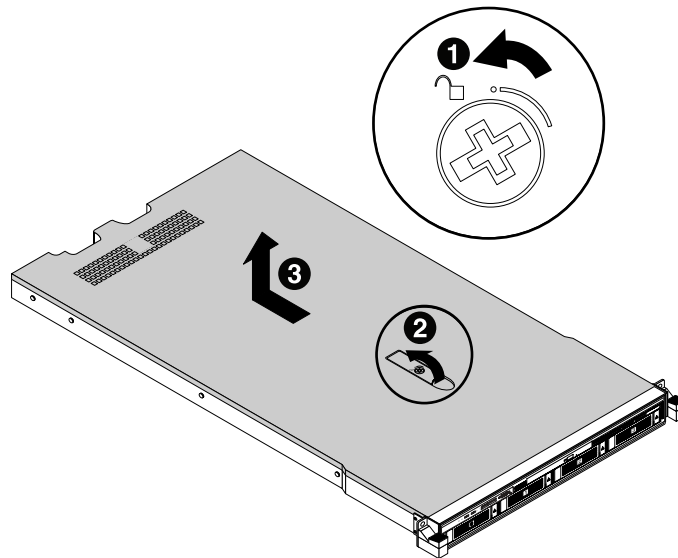

Figure 35. Removing the server cover

To reinstall the server cover, see “Reinstalling the server cover and reconnecting cables” on page 155.

**Attention:** For proper cooling and airflow, install the server cover before turning on the server. Operating the server with the server cover removed might damage server components.

---

## Installing, removing, or replacing hardware

This topic provides instructions on how to install, remove, or replace hardware for your server. You can expand the capabilities of your server by adding new hardware devices, such as memory modules or other server options, and maintain your server by replacing the failing hardware devices.

If you are handling a server option, refer to the appropriate installation or removal instructions in this topic along with the instructions that come with the option.

### Notes:

- Use only parts provided by Lenovo.
- Depending on the model, your server might look slightly different from the illustrations in this topic.

The EMI integrity and cooling of the server are protected by having all drive bays and PCIe card slots covered or occupied. When you install an internal drive or a PCIe card, save the EMI shield or dummy tray from the drive bay or save the PCIe card slot bracket in case that you later remove the device.

**Attention:** An unoccupied drive bay or PCIe card slot without a cover, shield, dummy tray, filler, or any other protection might impact the EMI integrity and cooling of the server, which might result in overheating or component damage.

## Removing and reinstalling the rack handles

**Attention:** Do not open your server or attempt any repair before reading and understanding “Read this first: safety information” on page v and “Guidelines” on page 59.

Before you begin, print all the related instructions or ensure that you can view the PDF version on another computer for reference.

To remove and reinstall the rack handles, do the following:

1. On each side of the server, remove the five screws that secure the rack handle and then remove the rack handle from the chassis.

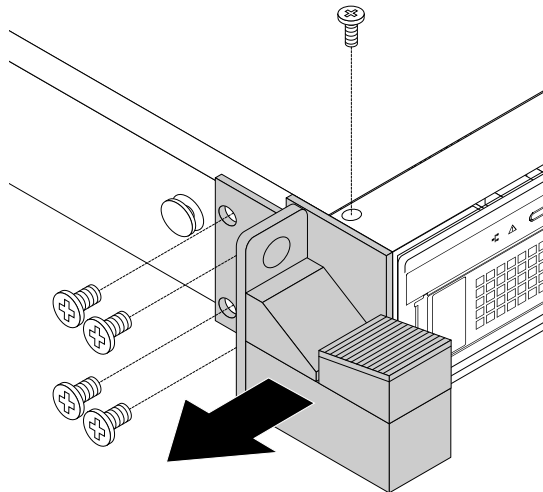

Figure 36. Removing the rack handles

2. To reinstall the rack handles, align the five screw holes in the rack handle with the corresponding holes in the chassis. Install the five screws to secure the rack handle on each side of the server.

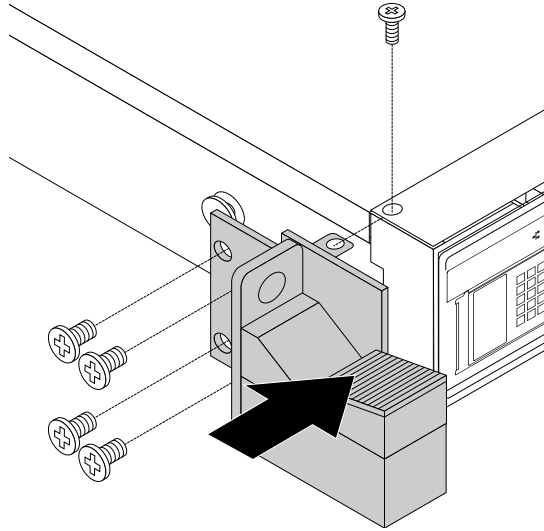

Figure 37. Installing the rack handles

## Removing and reinstalling the cooling shroud

To access some server components on the system board, remove the cooling shroud. To ensure proper cooling and airflow, reinstall the cooling shroud before turning on the server.

### Removing the cooling shroud

**Attention:** Do not open your server or attempt any repair before reading and understanding “Read this first: safety information” on page v and “Guidelines” on page 59.

Before you begin, print all the related instructions or ensure that you can view the PDF version on another computer for reference.

**Note:** Depending on the model, your server might look slightly different from the illustrations in this topic.

To remove the cooling shroud, do the following:

1. Remove all external media from the drives and turn off all attached devices and the server. Then, disconnect all power cords from electrical outlets and disconnect all cables that are connected to the server.
2. Prepare your server. See “Removing or extending the server from the rack cabinet” on page 61.
3. Remove the server cover. See “Removing the server cover” on page 61.
4. Insert a finger into each of the two holes **1** in the cooling shroud and then lift the cooling shroud out of the server.

**Attention:** For proper cooling and airflow, reinstall the cooling shroud before turning on the server. Operating the server for more than 30 minutes with the cooling shroud removed might damage server components.

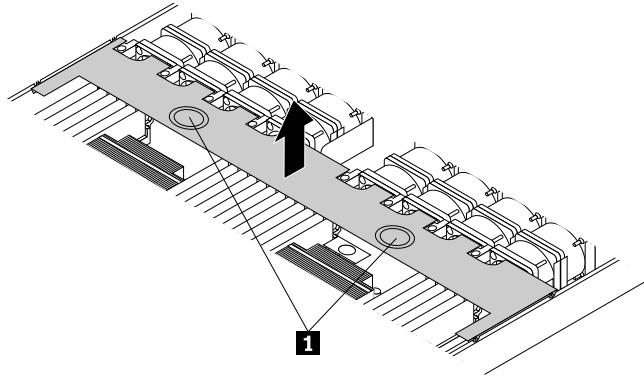

Figure 38. Removing the cooling shroud

## Reinstalling the cooling shroud

**Attention:** Do not open your server or attempt any repair before reading and understanding “Read this first: safety information” on page v and “Guidelines” on page 59.

Before you begin, print all the related instructions or ensure that you can view the PDF version on another computer for reference.

**Note:** Depending on the model, your server might look slightly different from the illustrations in this topic.

To reinstall the cooling shroud, do the following:

1. Ensure that all components have been reassembled correctly and that no tools or loose screws are left inside your server.
2. Ensure that all internal cables are routed correctly and secured by any cable clips or ties in the server. Keep cables clear of the hinges and sides of the server chassis to avoid interference with reinstalling the cooling shroud.
3. Note the orientation of the cooling shroud and then place it above the server so that the tabs on both sides of the cooling shroud are aligned with the corresponding holes or gaps in both sides of the chassis. Then, lower the cooling shroud into the chassis until it snaps into position.

**Note:** If necessary, gently press the cooling shroud on both sides so that the tabs on the cooling shroud completely engage with both sides of the chassis.

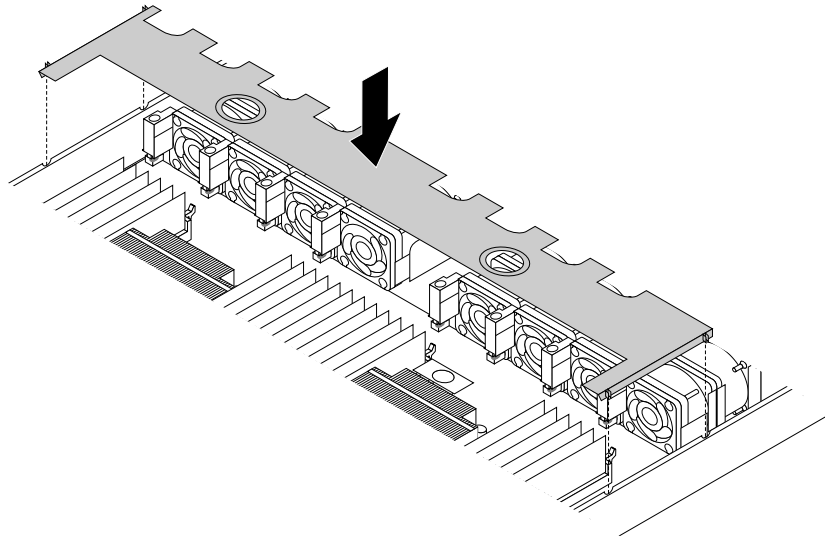

Figure 39. Reinstalling the cooling shroud

4. Reinstall the server cover and reconnect cables to the server. For more information, refer to “Reinstalling the server cover and reconnecting cables” on page 155.

## Installing or removing a memory module

**Note:** The memory modules are extremely sensitive to ESD. Ensure that you read and understand “Handling static-sensitive devices” on page 60 first and carefully perform the operation.

### Memory module installation rules

Your server has 24 memory slots.

- Each slot supports 4 GB, 8 GB, 16 GB, and 32 GB double data rate 4 registered dual inline memory modules (DDR4 RDIMMs).
- Each slot supports 32 GB and 64 GB DDR4 load-reduced dual inline memory modules (LRDIMMs).
- Your server supports up to 12 memory modules when one microprocessor is installed and up to 24 memory modules when two microprocessors are installed.
- The minimum system memory for RDIMMs is 4 GB (only one microprocessor installed and only one 4 GB RDIMM installed in the CPU1 DIMMA1 slot).
- The minimum system memory for LRDIMMs is 32 GB (only one microprocessor installed and only one 32 GB LRDIMM installed in the CPU1 DIMMA1 slot).
- The maximum system memory for RDIMMs is 768 GB (two microprocessors installed and one 32 GB RDIMM installed in each of the 24 memory slots).
- The maximum system memory for LRDIMMs is 1.5 TB (two microprocessors installed and one 64 GB LRDIMM installed in each of the 24 memory slots).
- The server supports at most 16 memory modules installed when it meets all the following conditions:
  - Twelve 2.5-inch-drive bays in the front (machine types 70CX and 70CY)
  - 550-watt hot-swap power supplies installed
  - CPU power: above 105 W but not exceeds 135 W

For more information about the memory modules in your specific server model, use the Setup Utility program. See “Viewing information in the Setup Utility program” on page 47.



For a list of the supported ThinkServer memory module options, go to:  
<http://lenovoquickpick.com/usa/home/thinkserver/rack-and-tower-server>

Before installing a memory module, ensure that you observe the following guidelines:

- All memory modules to be installed on a server must be the same type.
- When you install memory modules with different ranks in one channel, start from the farthest memory slot in the channel and install the memory module that has the most ranks first.
- When memory modules with different frequencies are installed into the memory slots for the same microprocessor, all the memory modules run at the lowest frequency.
- It is recommended that you install the high-frequency memory modules into the memory slots for the same microprocessor to ensure high performance.

The following illustration shows the memory module installation rules for servers that have only one microprocessor (CPU1) installed.

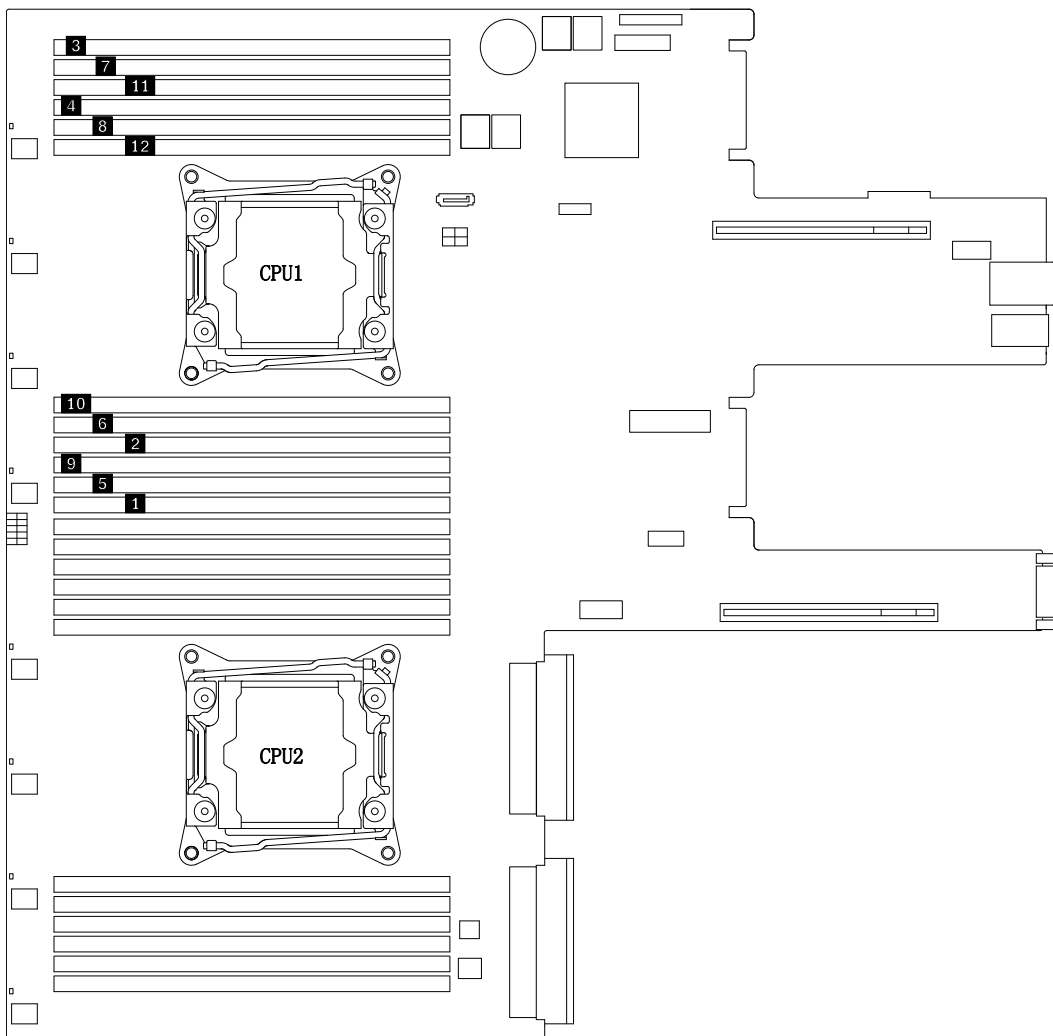

Figure 40. Memory module installation rules

The following illustration shows the memory module installation rules for servers that have two microprocessors (CPU1 and CPU2) installed.

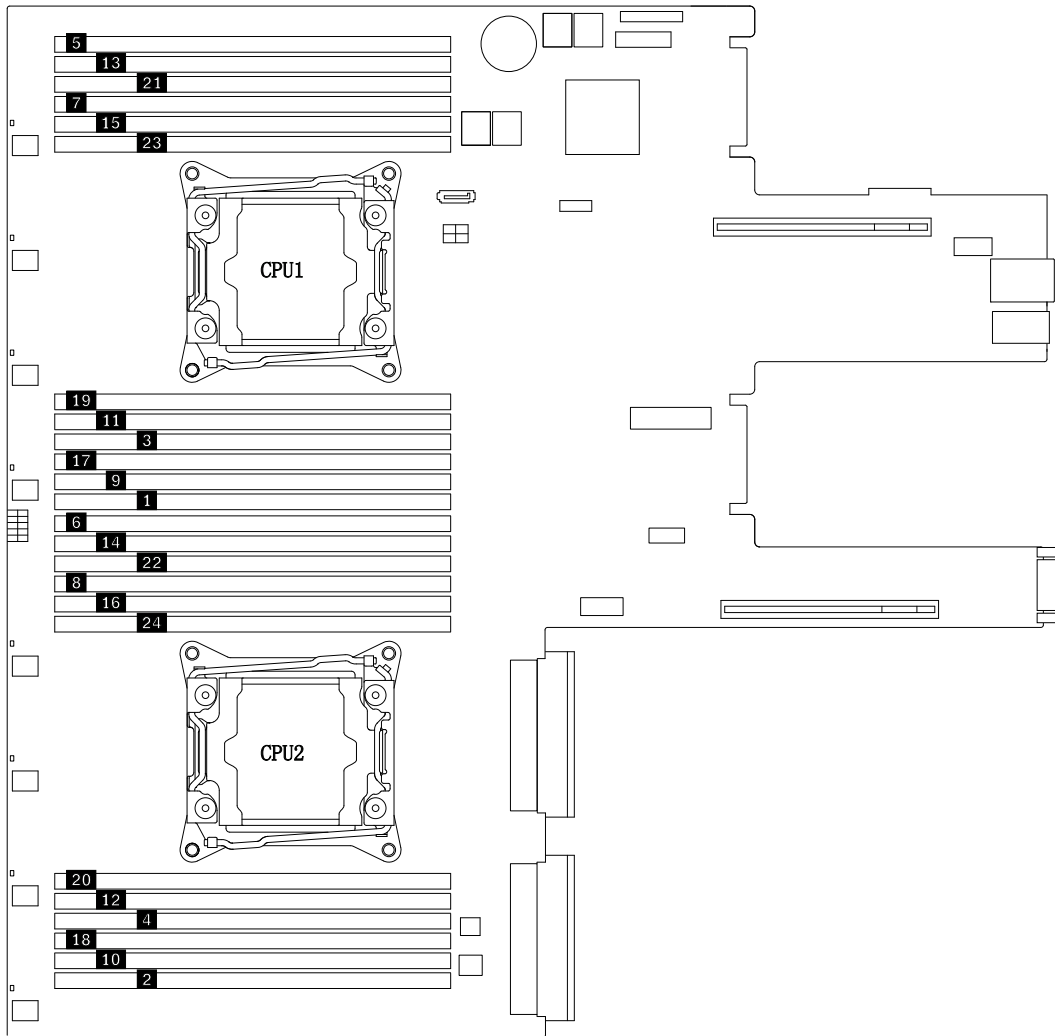

Figure 41. Memory module installation rules

## Installing a memory module

**Attention:** Do not open your server or attempt any repair before reading and understanding “Read this first: safety information” on page v and “Guidelines” on page 59.

Before you begin, print all the related instructions or ensure that you can view the PDF version on another computer for reference.

### Notes:

- To optimize system performance, ensure that you consider and follow the memory module installation rules when performing the operation. See “Memory module installation rules” on page 66.
- Use any documentation that comes with the memory module and follow those instructions in addition to the instructions in this topic.

To install a memory module, do the following:

1. Remove all external media from the drives and turn off all attached devices and the server. Then, disconnect all power cords from electrical outlets and disconnect all cables that are connected to the server.

2. Prepare your server. See “Removing or extending the server from the rack cabinet” on page 61.
3. Remove the server cover. See “Removing the server cover” on page 61.
4. Remove the cooling shroud. See “Removing and reinstalling the cooling shroud” on page 64.
5. Locate the memory slots on the system board and read the memory module installation rules. See “Memory module installation rules” on page 66.
6. Remove any parts or disconnect any cables that might prevent your access to the memory slots.
7. Open the retaining clips of the appropriate memory slot.

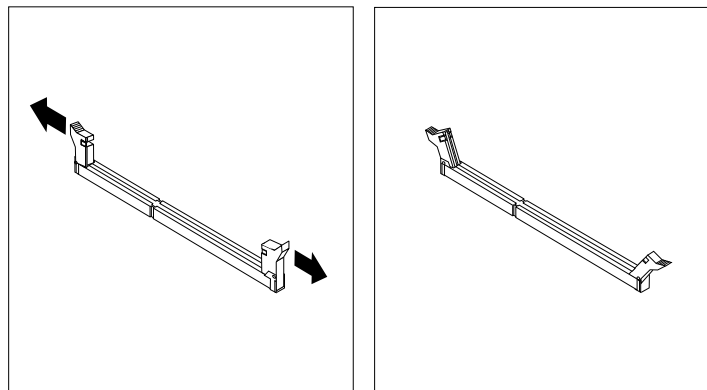

Figure 42. Opening the retaining clips of the memory slots

8. Touch the static-protective package that contains the new memory module to any unpainted surface on the outside of the server. Then, take the new memory module out of the package.

**Note:** Carefully handle the memory module by its edges.

9. Position the new memory module over the memory slot. Ensure that the notch **1** on the new memory module is aligned with the key **2** in the memory slot. Then, press the new memory module straight down into the memory slot until the retaining clips close and the new memory module snaps into position.

**Note:** If there is a gap between the memory module and the retaining clips, the memory module has not been installed correctly. Open the retaining clips, remove the memory module, and then reinstall it into the memory slot until the retaining clips are completely closed.

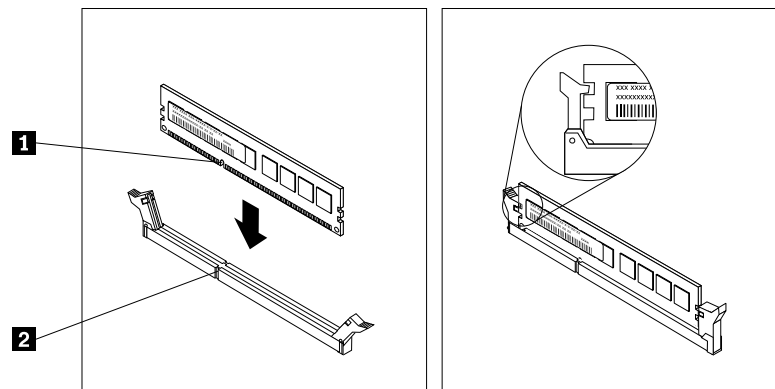

Figure 43. Installing a memory module

10. Reinstall any parts or reconnect any cables that you have removed.

**What to do next:**

- To work with another piece of hardware, go to the appropriate section.
- To complete the installation, go to “Completing the parts replacement” on page 154.

## Removing a memory module

**Attention:** Do not open your server or attempt any repair before reading and understanding “Read this first: safety information” on page v and “Guidelines” on page 59.

Before you begin, print all the related instructions or ensure that you can view the PDF version on another computer for reference.

**Note:** To optimize system performance, ensure that you consider and follow the memory module installation rules when performing the operation. See “Memory module installation rules” on page 66.

To remove a memory module, do the following:

1. Remove all external media from the drives and turn off all attached devices and the server. Then, disconnect all power cords from electrical outlets and disconnect all cables that are connected to the server.
2. Prepare your server. See “Removing or extending the server from the rack cabinet” on page 61.
3. Remove the server cover. See “Removing the server cover” on page 61.
4. Remove the cooling shroud. See “Removing and reinstalling the cooling shroud” on page 64.
5. Locate the memory slots on the system board and read the memory module installation rules. See “Memory module installation rules” on page 66.
6. Remove any parts or disconnect any cables that might prevent your access to the memory slots.
7. Locate the memory module that you want to remove and open the retaining clips on both ends of the memory slot. Then, grasp the memory module by its edges and carefully pull it straight up to remove it from the memory slot.

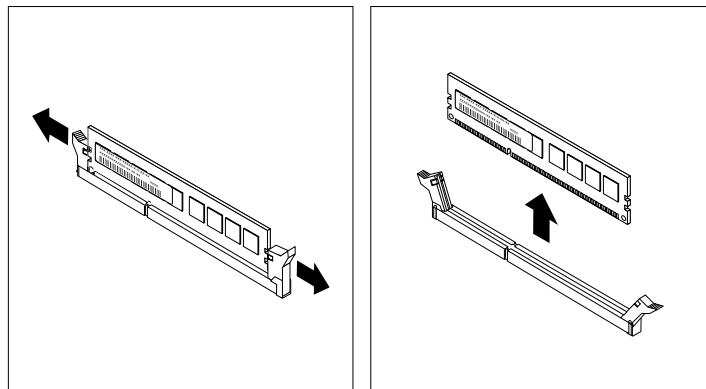

Figure 44. Removing a memory module

8. Reinstall any parts or reconnect any cables that you have removed.
9. If you are instructed to return the old memory module, follow all packaging instructions and use any packaging materials that are supplied to you for shipping.

### What to do next:

- To work with another piece of hardware, go to the appropriate section.
- To complete the removal procedure, go to “Completing the parts replacement” on page 154.

## Installing or removing the ThinkServer System Manager Premium module

The ThinkServer System Manager Premium (TSM Premium) offers convenient, remote KVM access and control through the LAN or Internet. You can use the TSM Premium to gain location-independent remote access to respond to critical incidents and to undertake necessary maintenance. Therefore, working as an integrated solution in your server, the TSM Premium provides an increased level of manageability over the basic server management available. You can purchase a TSM Premium module from Lenovo.

For a list of ThinkServer options, go to:

<http://lenovoquickpick.com/usa/home/thinkserver/rack-and-tower-server>

### Installing the TSM Premium module

**Attention:** Do not open your server or attempt any repair before reading and understanding “Read this first: safety information” on page v and “Guidelines” on page 59.

Before you begin, print all the related instructions or ensure that you can view the PDF version on another computer for reference.

#### Notes:

- Use any documentation that comes with the TSM Premium module and follow those instructions in addition to the instructions in this topic.
- Depending on the model, your server might look slightly different from the illustration in this topic.

To install the TSM Premium module, do the following:

1. Remove all external media from the drives and turn off all attached devices and the server. Then, disconnect all power cords from electrical outlets and disconnect all cables that are connected to the server.
2. Prepare your server. See “Removing or extending the server from the rack cabinet” on page 61.
3. Remove the server cover. See “Removing the server cover” on page 61.
4. Remove the riser card assembly 2. See “Replacing the riser card assembly” on page 147.
5. Touch the static-protective package that contains the TSM Premium module to any unpainted surface on the outside of the server. Then, take the TSM Premium module out of the package.
6. Locate the TSM Premium module connector on the system board and then insert the TSM Premium module into the TSM Premium module connector.

**Note:** Ensure that the TSM Premium module is securely seated on the system board.

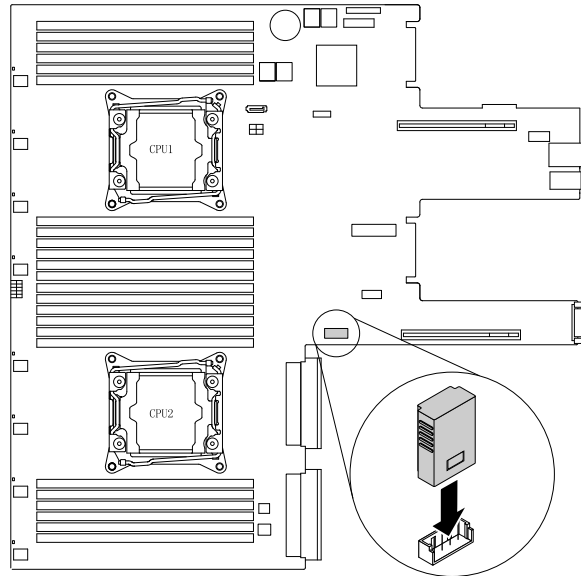

Figure 45. Installing the TSM Premium module

7. Reinstall the riser card assembly 2. See “Replacing the riser card assembly” on page 147.

#### What to do next:

- To work with another piece of hardware, go to the appropriate section.
- To complete the installation, go to “Completing the parts replacement” on page 154. For information about server remote management, download and read the *ThinkServer System Manager User Guide* at: <http://www.lenovo.com/UserManuals>

## Removing the TSM Premium module

**Attention:** Do not open your server or attempt any repair before reading and understanding “Read this first: safety information” on page v and “Guidelines” on page 59.

Before you begin, print all the related instructions or ensure that you can view the PDF version on another computer for reference.

#### Notes:

- Use any documentation that comes with the TSM Premium module and follow those instructions in addition to the instructions in this topic.
- If you remove the TSM Premium module, the iKVM function for server remote management will be unavailable.
- Depending on the model, your server might look slightly different from the illustration in this topic.

To remove the TSM Premium module, do the following:

1. Remove all external media from the drives and turn off all attached devices and the server. Then, disconnect all power cords from electrical outlets and disconnect all cables that are connected to the server.
2. Prepare your server. See “Removing or extending the server from the rack cabinet” on page 61.
3. Remove the server cover. See “Removing the server cover” on page 61.
4. Remove the riser card assembly 2. See “Replacing the riser card assembly” on page 147.

5. Locate the TSM Premium module on the system board and then lift the TSM Premium module straight up to remove it from the TSM Premium module connector.

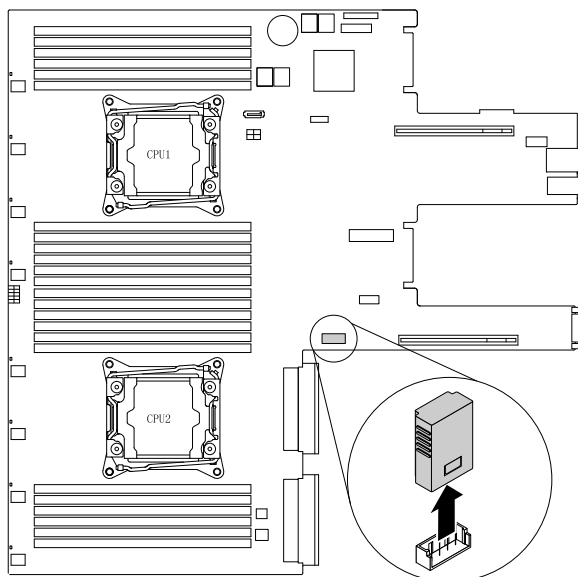

Figure 46. Removing the TSM Premium module

6. Reinstall the riser card assembly 2. See “Replacing the riser card assembly” on page 147.
7. If you are instructed to return the old TSM Premium module, follow all packaging instructions and use any packaging materials that are supplied to you for shipping.

#### What to do next:

- To work with another piece of hardware, go to the appropriate section.
- To complete the removal procedure, go to “Completing the parts replacement” on page 154.

## Installing or removing the ThinkServer Trusted Platform Module

The ThinkServer Trusted Platform Module (hereinafter referred to as the TPM) is a security chip designed by the Trusted Computing Group (TCG) to provide a hardware method of data encryption. It stores passwords, encryption keys, and digital certificates to help provide security solutions and protect the server. You can purchase a TPM option from Lenovo.

### Installing the TPM

**Attention:** Do not open your server or attempt any repair before reading and understanding “Read this first: safety information” on page v and “Guidelines” on page 59.

Before you begin, print all the related instructions or ensure that you can view the PDF version on another computer for reference.

#### Notes:

- Use any documentation that comes with the TPM and follow those instructions in addition to the instructions in this topic.
- Depending on the model, your server might look slightly different from the illustration in this topic.

To install the TPM, do the following:

1. Remove all external media from the drives and turn off all attached devices and the server. Then, disconnect all power cords from electrical outlets and disconnect all cables that are connected to the server.
2. Prepare your server. See “Removing or extending the server from the rack cabinet” on page 61.
3. Remove the server cover. See “Removing the server cover” on page 61.
4. Remove the riser card assembly 1 and 2 if needed. See “Replacing the riser card assembly” on page 147.
5. Touch the static-protective package that contains the TPM to any unpainted surface on the outside of the server. Then, take the TPM out of the package.

**Note:** Carefully handle the TPM by its edges.

6. Locate the TPM connector on the system board and then insert the TPM into the TPM connector on the system board.

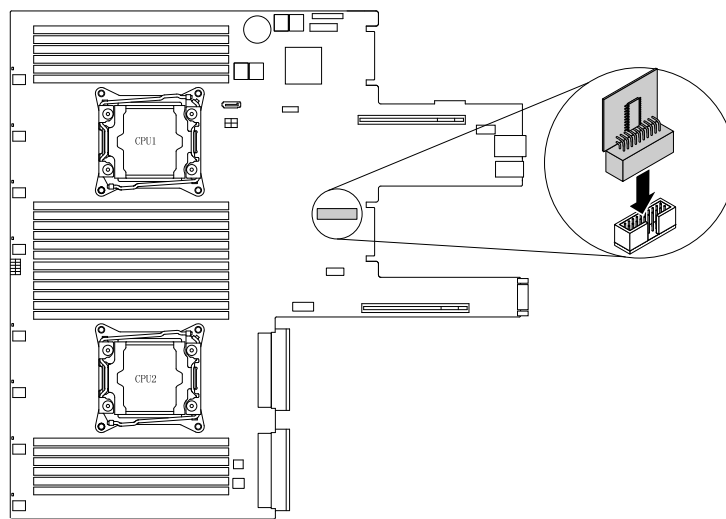

Figure 47. Installing the TPM

#### What to do next:

- To work with another piece of hardware, go to the appropriate section.
- To complete the installation, go to “Completing the parts replacement” on page 154. Then, you can configure the TPM function in the Setup Utility program. See “Configuring the TPM function” on page 52.

#### Removing the TPM

**Attention:** Do not open your server or attempt any repair before reading and understanding “Read this first: safety information” on page v and “Guidelines” on page 59.

This topic provides instructions on how to remove the TPM if the server has one installed.

Before you begin, print all the related instructions or ensure that you can view the PDF version on another computer for reference.

#### Notes:

- If you remove the TPM, the TPM function will be unavailable.
- Use any documentation that comes with the TPM and follow those instructions in addition to the instructions in this topic.



- Depending on the model, your server might look slightly different from the illustration in this topic.

To remove the TPM, do the following:

1. Remove all external media from the drives and turn off all attached devices and the server. Then, disconnect all power cords from electrical outlets and disconnect all cables that are connected to the server.
2. Prepare your server. See “Removing or extending the server from the rack cabinet” on page 61.
3. Remove the server cover. See “Removing the server cover” on page 61.
4. Locate the TPM on the system board and then remove the TPM from the TPM connector by lifting it straight up.

**Note:** Carefully handle the TPM by its edges.

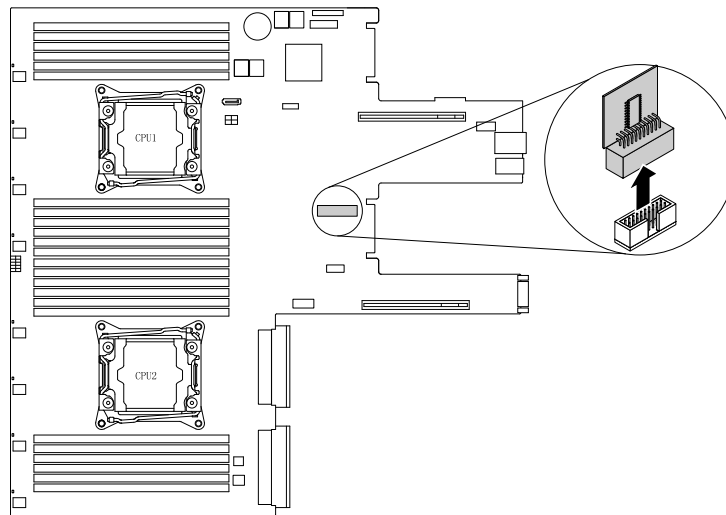

Figure 48. Removing the TPM

5. If you are instructed to return the old TPM, follow all packaging instructions and use any packaging materials that are supplied to you for shipping.

#### What to do next:

- To work with another piece of hardware, go to the appropriate section.
- To complete the removal procedure, go to “Completing the parts replacement” on page 154.

## Installing or removing the RAID 110i upgrade key

The Lenovo ThinkServer RAID 110i upgrade key (hereinafter referred to as RAID 110i key) activates RAID 5 for the onboard SATA software RAID. As a result, the capability of the system board is expanded. You can purchase a RAID 110i key from Lenovo and install it to the RAID upgrade key connector on the system board.

For a list of ThinkServer options, go to:

<http://lenovoquickpick.com/usa/home/thinkserver/rack-and-tower-server>

### Installing the RAID 110i key

**Attention:** Do not open your server or attempt any repair before reading and understanding “Read this first: safety information” on page v and “Guidelines” on page 59.

Before you begin, print all the related instructions or ensure that you can view the PDF version on another computer for reference.

**Note:** Use any documentation that comes with the RAID 110i key and follow those instructions in addition to the instructions in this topic.

To install the RAID 110i key, do the following:

1. Remove all external media from the drives and turn off all attached devices and the server. Then, disconnect all power cords from electrical outlets and disconnect all cables that are connected to the server.
2. Prepare your server. See “Removing or extending the server from the rack cabinet” on page 61.
3. Remove the server cover. See “Removing the server cover” on page 61.
4. Touch the static-protective package that contains the RAID 110i key to any unpainted surface on the outside of the server. Then, take the RAID 110i key out of the package.

**Note:** Carefully handle the RAID 110i key by its edges.

5. Locate the RAID upgrade key connector on the system board and then insert the RAID 110i key into the RAID upgrade key connector on the system board.

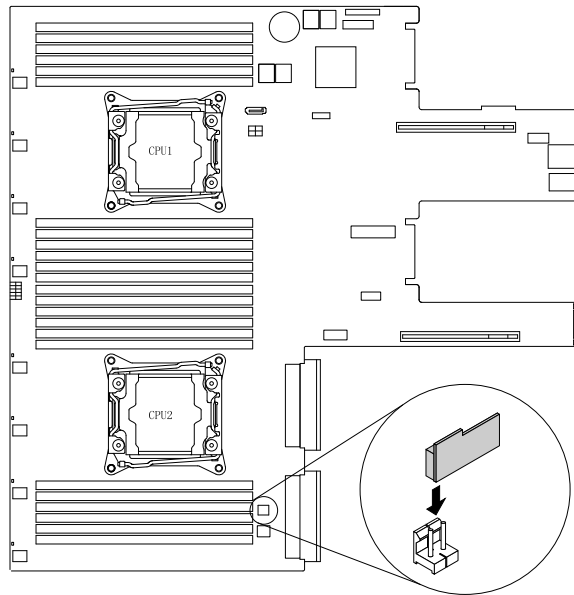

Figure 49. Installing the RAID 110i key

#### What to do next:

- To work with another piece of hardware, go to the appropriate section.
- To complete the installation, go to “Completing the parts replacement” on page 154.

#### Removing the RAID 110i key

**Attention:** Do not open your server or attempt any repair before reading and understanding “Read this first: safety information” on page v and “Guidelines” on page 59.

Before you begin, print all the related instructions or ensure that you can view the PDF version on another computer for reference.

**Notes:**

- If you remove the RAID 110i key, the onboard SATA software RAID function will be unavailable.
- Use any documentation that comes with the RAID 110i key and follow those instructions in addition to the instructions in this topic.

To remove the RAID 110i key, do the following:

1. Remove all external media from the drives and turn off all attached devices and the server. Then, disconnect all power cords from electrical outlets and disconnect all cables that are connected to the server.
2. Prepare your server. See “Removing or extending the server from the rack cabinet” on page 61.
3. Remove the server cover. See “Removing the server cover” on page 61.
4. Locate the RAID upgrade key connector on the system board. Then, remove the installed RAID 110i key by lifting it straight up.

**Note:** Carefully handle the RAID 110i key by its edges.

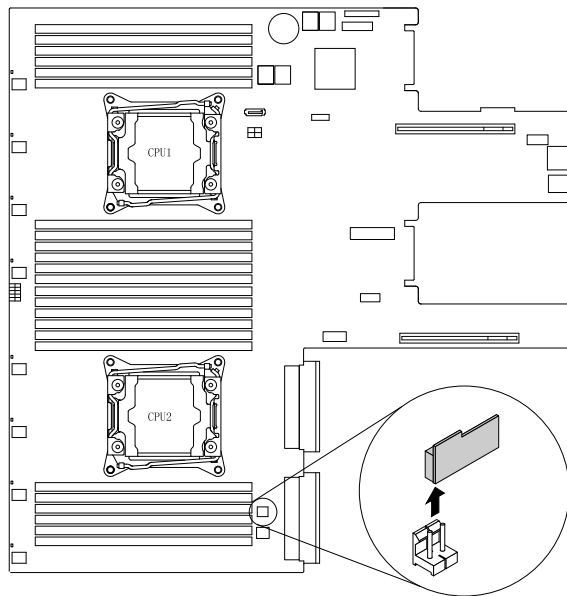

Figure 50. Removing the RAID 110i key

5. If you are instructed to return the old RAID 110i key, follow all packaging instructions and use any packaging materials that are supplied to you for shipping.

**What to do next:**

- To work with another piece of hardware, go to the appropriate section.
- To complete the removal procedure, go to “Completing the parts replacement” on page 154.

## Installing or removing the Lenovo ThinkServer RAID 510i/520i upgrade key

The following two RAID upgrade keys activate RAID 5 and RAID 50 levels for advanced SATA or SAS hardware RAID:

- Lenovo ThinkServer RAID 510i upgrade key (requires the Lenovo ThinkServer RAID 510i AnyRAID Adapter)
- Lenovo ThinkServer RAID 520i upgrade key (requires the Lenovo ThinkServer RAID 520i PCIe Adapter)

You can purchase a RAID upgrade key from Lenovo at:

<http://lenovoquickpick.com/usa/home/thinkserver/rack-and-tower-server>

**Note:** The illustrations in this topic show how to install and remove the RAID 510i upgrade key. The procedure for installing or removing the RAID 520i upgrade key is similar.

## Installing the RAID upgrade key

**Attention:** Do not open your server or attempt any repair before reading and understanding “Read this first: safety information” on page v and “Guidelines” on page 59.

Before you begin, print all the related instructions or ensure that you can view the PDF version on another computer for reference.

**Note:** Use any documentation that comes with the RAID upgrade key and follow those instructions in addition to the instructions in this topic.

To install the RAID upgrade key, do the following:

1. Remove all external media from the drives and turn off all attached devices and the server. Then, disconnect all power cords from electrical outlets and disconnect all cables that are connected to the server.
2. Prepare your server. See “Removing or extending the server from the rack cabinet” on page 61.
3. Remove the server cover. See “Removing the server cover” on page 61.
4. Locate the RAID 510i AnyRAID aAdapter or the RAID 520i PCIe adapter.

**Note:** If necessary, remove the RAID 510i AnyRAID adapter or the RAID 520i PCIe adapter first for easier operation. See “Replacing the AnyRAID adapter” on page 108 or “Removing a PCIe card” on page 96.

5. Touch the static-protective package that contains the RAID upgrade key to any unpainted surface on the outside of the server. Then, take the RAID upgrade key out of the package.

**Note:** Carefully handle the RAID upgrade key by its edges.

6. Do one of the following:
  - If you are installing the RAID 510i upgrade key, insert the key into the RAID upgrade key connector on the RAID 510i AnyRAID adapter. Ensure that the key is securely seated.
  - If you are installing the RAID 520i upgrade key, insert the key into the J3 connector on the RAID 520i PCIe adapter. Ensure that the key is securely seated.

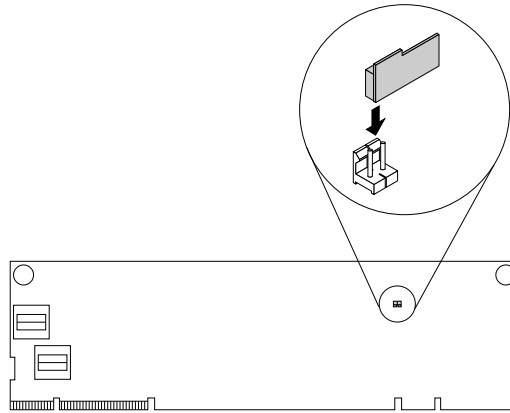

Figure 51. Installing the RAID 510i upgrade key

7. Reinstall the RAID 510i AnyRAID adapter or the RAID 520i PCIe adapter if you have removed it.

**What to do next:**

- To work with another piece of hardware, go to the appropriate section.
- To complete the installation, go to “Completing the parts replacement” on page 154. Then, the hardware RAID 5 and RAID 50 levels are available for your server if your server has the required number of hard disk drives installed. For information about how to configure the hardware RAID, refer to the *MegaRAID SAS Software User Guide* on the Lenovo Support Web site at: <http://www.lenovo.com/support>

## Removing the RAID upgrade key

**Attention:** Do not open your server or attempt any repair before reading and understanding “Read this first: safety information” on page v and “Guidelines” on page 59.

Before you begin, print all the related instructions or ensure that you can view the PDF version on another computer for reference.

**Attention:** Removing the RAID upgrade key might impact your RAID configurations. Back up your data before you begin to avoid any data loss due to a RAID configuration change.

**Notes:**

- If you remove the RAID upgrade key, the hardware RAID 5 and RAID 50 levels will be disabled.
- Use any documentation that comes with the RAID upgrade key and follow those instructions in addition to the instructions in this topic.

To remove the RAID upgrade key, do the following:

1. Remove all external media from the drives and turn off all attached devices and the server. Then, disconnect all power cords from electrical outlets and disconnect all cables that are connected to the server.
2. Prepare your server. See “Removing or extending the server from the rack cabinet” on page 61.
3. Remove the server cover. See “Removing the server cover” on page 61.
4. Locate the RAID upgrade key that you want to remove. Then, remove the RAID upgrade key from the RAID 510i AnyRAID adapter or the RAID 520i PCIe adapter.

**Note:** If necessary, remove the RAID 510i AnyRAID adapter or the RAID 520i PCIe adapter first for easier operation. After you remove the upgrade key, reinstall the adapter. See “Replacing the AnyRAID adapter” on page 108 or “Removing a PCIe card” on page 96.

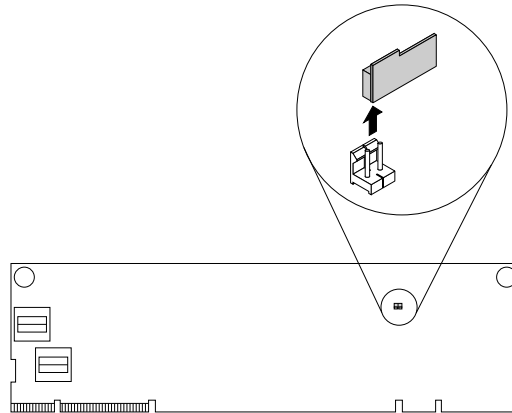

Figure 52. Removing the RAID 510i upgrade key

5. If you are instructed to return the old RAID upgrade key, follow all packaging instructions and use any packaging materials that are supplied to you for shipping.

**What to do next:**

- To work with another piece of hardware, go to the appropriate section.
- To complete the removal procedure, go to “Completing the parts replacement” on page 154. As the hardware RAID 5 and 50 levels are not available without the RAID upgrade key, you might need to reconfigure RAID for your server. For information about how to configure the hardware RAID, refer to the *MegaRAID SAS Software User Guide* on the Lenovo Support Web site at: <http://www.lenovo.com/support>

## Installing or removing the Thunderbolt Memory Module

This topic applies only to RAID adapters that support the TMM. The following two types of TMM are available:

- ThinkServer RAID 720i Modular Flash
- ThinkServer RAID 720i Modular DRAM Upgrade

The TMM works as the cache memory for the following adapters:

- RAID 720i AnyRAID Adapter
- RAID 720ix AnyRAID Adapter
- RAID 720i PCIe Adapter

You can purchase a TMM from the Lenovo Web site at:

<http://lenovoquickpick.com/usa/home/thinkserver/rack-and-tower-server>

**Note:** The illustrations in this topic show how to install and remove the TMM on the AnyRAID Adapter. For the RAID 720i PCIe Adapter, the procedure is similar.

### Installing the TMM

**Attention:** Do not open your server or attempt any repair before reading and understanding “Read this first: safety information” on page v and “Guidelines” on page 59.

Before you begin, print all the related instructions or ensure that you can view the PDF version on another computer for reference.

### Notes:

- Use any documentation that comes with the TMM and follow those instructions in addition to the instructions in this topic.
- Depending on the specific type, your AnyRAID adapter and TMM might look different from the illustration in this topic.

To install the TMM, do the following:

1. Remove all external media from the drives and turn off all attached devices and the server. Then, disconnect all power cords from electrical outlets and disconnect all cables that are connected to the server.
2. Prepare your server. See “Removing or extending the server from the rack cabinet” on page 61.
3. Remove the server cover. See “Removing the server cover” on page 61.
4. Locate the AnyRAID adapter or the RAID 720i PCIe adapter.
5. Align the two holes in the TMM with the two pins on the AnyRAID adapter or the RAID 720i PCIe adapter. Then, lower the TMM straight down until it is securely seated.

**Note:** If necessary, remove the AnyRAID adapter or the RAID 720i PCIe adapter first for easier operation. After you install the TMM, reinstall the adapter. See “Replacing the AnyRAID adapter” on page 108 or “Installing or removing a PCIe card” on page 93.

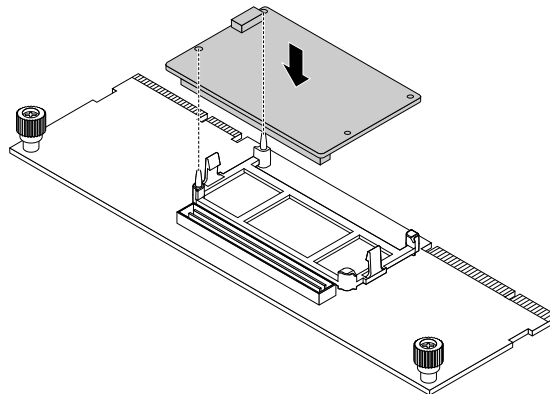

Figure 53. Installing the TMM

### What to do next:

- To work with another piece of hardware, go to the appropriate section.
- To complete the installation, go to “Completing the parts replacement” on page 154.

## Removing the TMM

**Attention:** Do not open your server or attempt any repair before reading and understanding “Read this first: safety information” on page v and “Guidelines” on page 59.

Before you begin, print all the related instructions or ensure that you can view the PDF version on another computer for reference.

**Note:** Use any documentation that comes with the flash module and follow those instructions in addition to the instructions in this topic.

To remove the TMM, do the following:

1. Remove all external media from the drives and turn off all attached devices and the server. Then, disconnect all power cords from electrical outlets and disconnect all cables that are connected to the server.
2. Prepare your server. See “Removing or extending the server from the rack cabinet” on page 61.
3. Remove the server cover. See “Removing the server cover” on page 61.
4. Locate the AnyRAID adapter or the RAID 720i PCIe adapter.
5. Pivot the two release tabs **1** outward and remove the TMM from the AnyRAID adapter or the RAID 720i PCIe adapter.

**Note:** If necessary, remove the AnyRAID adapter or the RAID 720i PCIe adapter first for easier operation. After you remove the TMM, reinstall the adapter. See “Replacing the AnyRAID adapter” on page 108 or “Installing or removing a PCIe card” on page 93.

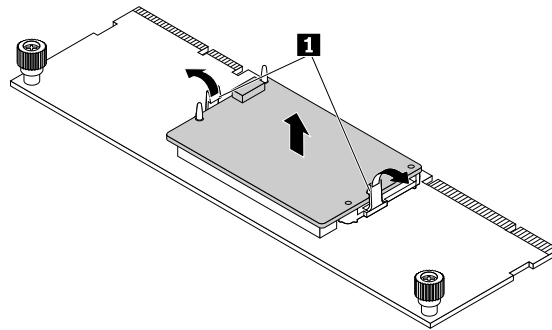

Figure 54. Removing the TMM

6. If you are instructed to return the old TMM, follow all packaging instructions and use any packaging materials that are supplied to you for shipping.

#### What to do next:

- To work with another piece of hardware, go to the appropriate section.
- To complete the removal procedure, go to “Completing the parts replacement” on page 154.

## Installing or removing the SD module

If you equip your server with an SD module, you can install up to two SD cards into the SD module for data storage. You can purchase an SD module and SD cards from Lenovo.

For a list of ThinkServer options, go to:

<http://lenovoquickpick.com/usa/home/thinkserver/rack-and-tower-server>

## Installing the SD module

**Attention:** Do not open your server or attempt any repair before reading and understanding “Read this first: safety information” on page v and “Guidelines” on page 59.

Before you begin, print all the related instructions or ensure that you can view the PDF version on another computer for reference.



**Note:** Use any documentation that comes with the SD module and follow those instructions in addition to the instructions in this topic.

To install the SD module, do the following:

1. Remove all external media from the drives and turn off all attached devices and the server. Then, disconnect all power cords from electrical outlets and disconnect all cables that are connected to the server.
2. Prepare your server. See “Removing or extending the server from the rack cabinet” on page 61.
3. Remove the server cover. See “Removing the server cover” on page 61.
4. Remove the riser card assembly 2. See “Replacing the riser card assembly” on page 147.
5. Locate the SD module connector on the system board. See “System board components” on page 35. Remove any parts and disconnect any cables that might impede your operation.
6. Touch the static-protective package that contains the SD module to any unpainted surface on the outside of the server. Then, take the SD module out of the package.

**Note:** Carefully handle the SD module by its edges.

7. Insert the SD card into the SD card slot. The card might stop before it is completely installed into the SD module. Ensure that you insert the card firmly until you hear a click.
8. Position the SD module on the system board. Ensure that the plastic pins on the system board pass through the corresponding holes in the SD module. Then, press the SD module downward so that it is secured by the latch **1**.

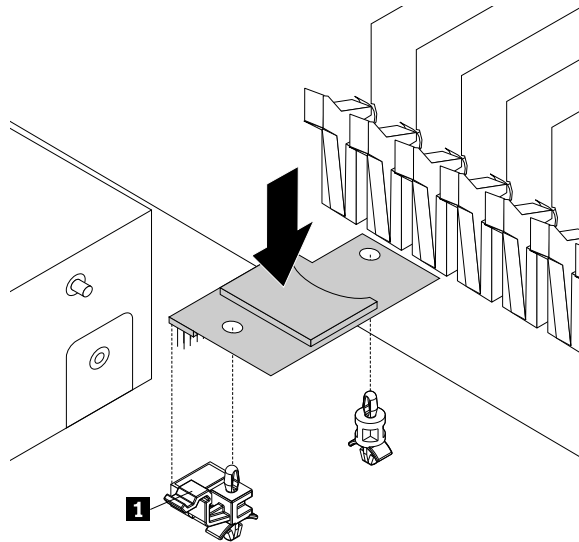

Figure 55. Installing the SD module

**What to do next:**

- To work with another piece of hardware, go to the appropriate section.
- To complete the installation, go to “Completing the parts replacement” on page 154.

**Removing the SD module**

**Attention:** Do not open your server or attempt any repair before reading and understanding “Read this first: safety information” on page v and “Guidelines” on page 59.

Before you begin, print all the related instructions or ensure that you can view the PDF version on another computer for reference.

**Note:** Use any documentation that comes with the SD module and follow those instructions in addition to the instructions in this topic.

To remove the SD module, do the following:

1. Remove all external media from the drives and turn off all attached devices and the server. Then, disconnect all power cords from electrical outlets and disconnect all cables that are connected to the server.
2. Prepare your server. See “Removing or extending the server from the rack cabinet” on page 61.
3. Remove the server cover. See “Removing the server cover” on page 61.
4. Remove the riser card assembly 2. See “Replacing the riser card assembly” on page 147.
5. Locate the SD module. See “Server components” on page 24.
6. Press the release latch **1** downward and lift the SD module straight up and off the system board.

**Note:** Carefully handle the SD module by its edges.

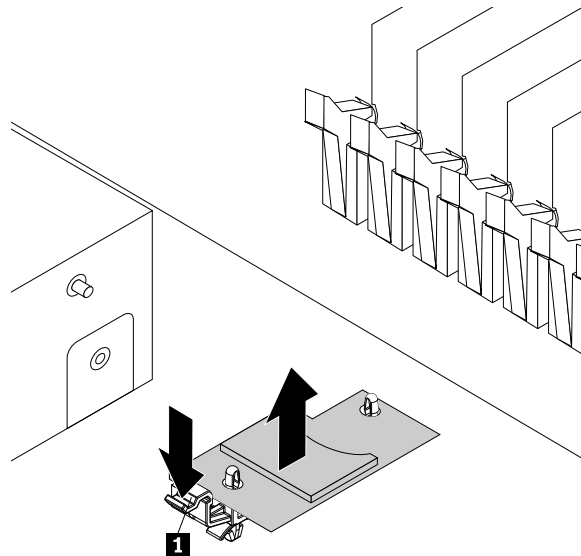

Figure 56. Removing the SD module

7. Push the SD card inward a little until you hear a click. Then, release it. The SD card ejects. Gently slide the card out of the card slot.
8. If you are instructed to return the old SD module, follow all packaging instructions and use any packaging materials that are supplied to you for shipping.

#### What to do next:

- To work with another piece of hardware, go to the appropriate section.
- To complete the removal procedure, go to “Completing the parts replacement” on page 154.

## Installing or removing the M.2 storage module

The M.2 storage module provides an easy way for data storage. You can install two M.2 storage drives into the M.2 storage module. You can purchase M.2 storage modules and M.2 storage drives from Lenovo.

For a list of ThinkServer options, go to:

<http://lenovoquickpick.com/usa/home/thinkserver/rack-and-tower-server>

## Installing the M.2 storage module

**Attention:** Do not open your server or attempt any repair before reading and understanding “Read this first: safety information” on page v and “Guidelines” on page 59.

Before you begin, print all the related instructions or ensure that you can view the PDF version on another computer for reference.

**Note:** Use any documentation that comes with the M.2 storage module and follow those instructions in addition to the instructions in this topic.

To install the M.2 storage module, do the following:

1. Remove all external media from the drives and turn off all attached devices and the server. Then, disconnect all power cords from electrical outlets and disconnect all cables that are connected to the server.
2. Prepare your server. See “Removing or extending the server from the rack cabinet” on page 61.
3. Remove the server cover. See “Removing the server cover” on page 61.
4. Remove the riser card assembly 2. See “Replacing the riser card assembly” on page 147.
5. On the system board, locate the three plastic pins for securing the M.2 storage module.
6. Touch the static-protective package that contains the M.2 storage module to any unpainted surface on the outside of the server. Then, take the M.2 storage module out of the package.

**Note:** Carefully handle the M.2 storage module by its edges.

7. Install the M.2 storage drive into the drive slot on the M.2 storage module. Then, install the screw to secure the M.2 storage drive.

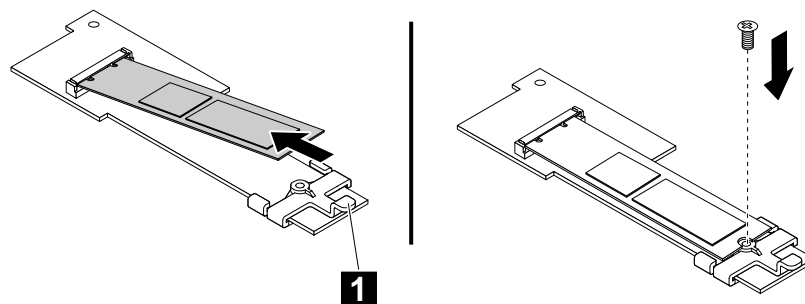

Figure 57. Installing the M.2 storage drive

8. Position the M.2 storage module on the system board so that the three plastic pins pass through the corresponding holes in the M.2 storage module. Then, press the M.2 storage module downward until it is secured by the latches **1**.

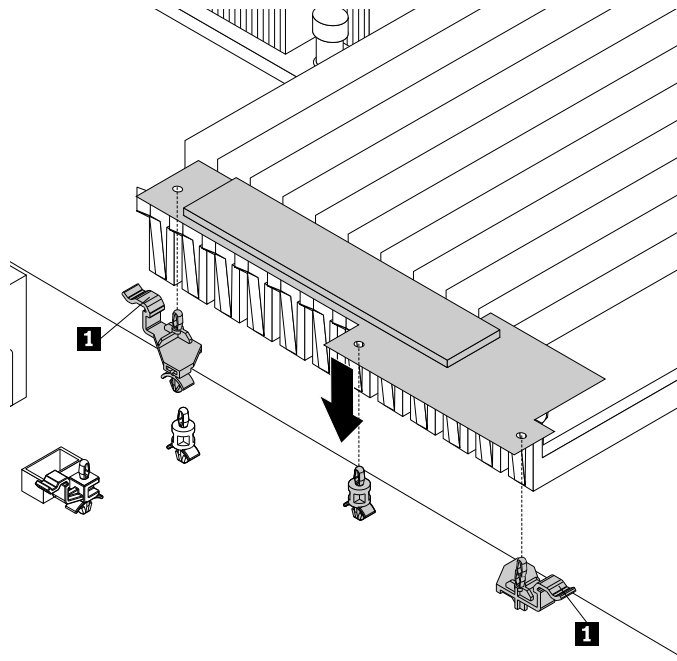

Figure 58. Installing the M.2 storage module

9. Connect the 6-pin signal cable of the M.2 storage module to the rear backplane signal connector on the system board. Then, connect the SATA signal cable of the M.2 storage module to one of the following connectors:
  - The SATA connector 1 (ports 4-7) on the system board if your server has no backplane and AnyRAID adapter installed. See “System board components” on page 35.
  - The SATA connector on the Lenovo ThinkServer RAID 720ix AnyRAID Adapter if one is installed. See “RAID adapter” on page 27.
  - The signal cable connector on the backplane for 3.5-inch drives if your server has one of the following AnyRAID adapter installed:
    - Lenovo ThinkServer RAID 110i AnyRAID Adapter
    - Lenovo ThinkServer RAID 510i AnyRAID Adapter
    - Lenovo ThinkServer RAID 720i AnyRAID Adapter
 See “Backplane for up to four 3.5-inch drives” on page 32.

**What to do next:**

- To work with another piece of hardware, go to the appropriate section.
- To complete the installation, go to “Completing the parts replacement” on page 154.

**Removing the M.2 storage module**

**Attention:** Do not open your server or attempt any repair before reading and understanding “Read this first: safety information” on page v and “Guidelines” on page 59.

Before you begin, print all the related instructions or ensure that you can view the PDF version on another computer for reference.

**Note:** Use any documentation that comes with the M.2 storage module and follow those instructions in addition to the instructions in this topic.

To remove the M.2 storage module, do the following:

1. Remove all external media from the drives and turn off all attached devices and the server. Then, disconnect all power cords from electrical outlets and disconnect all cables that are connected to the server.
2. Prepare your server. See “Removing or extending the server from the rack cabinet” on page 61.
3. Remove the server cover. See “Removing the server cover” on page 61.
4. Remove the riser card assembly 2. See “Replacing the riser card assembly” on page 147.
5. Locate the M.2 storage module and disconnect the cables.
6. Press the two latches  downward as shown and lift the M.2 storage module from the system board.

**Note:** Carefully handle the M.2 storage module by its edges.

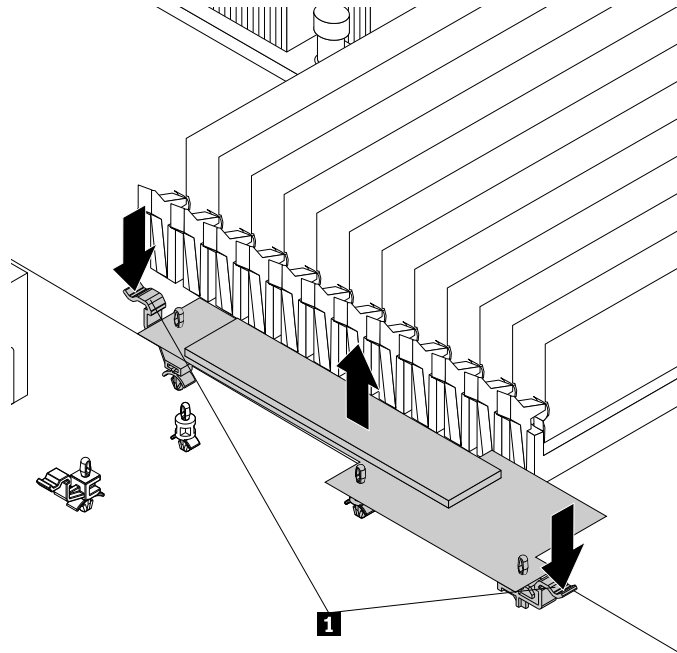

Figure 59. Removing the M.2 storage module

7. Remove the screw that secures the M.2 storage drive. Then, remove the M.2 storage drive.

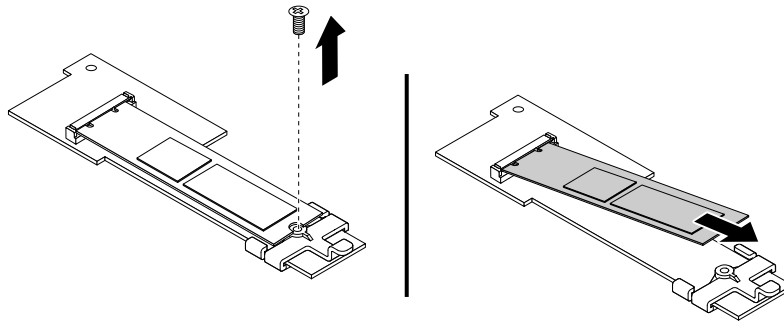

Figure 60. Removing the M.2 storage drive

8. If you are instructed to return the old M.2 storage module, follow all packaging instructions and use any packaging materials that are supplied to you for shipping.

**What to do next:**

- To work with another piece of hardware, go to the appropriate section.
- To complete the removal procedure, go to “Completing the parts replacement” on page 154.

## Installing or removing the AnyFabric adapter

The AnyFabric adapter provides expansion connectors to connect devices, such as solid-state drives and other expansion cards. You can purchase an AnyFabric adapter from Lenovo.

For a list of ThinkServer options, go to:

<http://lenovoquickpick.com/usa/home/thinkserver/rack-and-tower-server>

**Note:** If your server comes with the Lenovo ThinkServer RAID 110i AnyRAID Adapter, do not use the X710-4 AnyFabric adapter. The X710-4 AnyFabric adapter is not active in this situation.

### Installing the AnyFabric adapter

**Attention:** Do not open your server or attempt any repair before reading and understanding “Read this first: safety information” on page v and “Guidelines” on page 59.

Before you begin, print all the related instructions or ensure that you can view the PDF version on another computer for reference.

**Notes:**

- Use any documentation that comes with the AnyFabric adapter and follow those instructions in addition to the instructions in this topic.
- Depending on the model, your server might look slightly different from the illustration in this topic.

To install the AnyFabric adapter, do the following:

1. Remove all external media from the drives and turn off all attached devices and the server. Then, disconnect all power cords from electrical outlets and disconnect all cables that are connected to the server.
2. Prepare your server. See “Removing or extending the server from the rack cabinet” on page 61.
3. Remove the server cover. See “Removing the server cover” on page 61.
4. Locate the AnyFabric adapter connector on the system board. See “System board components” on page 35.

5. Remove the riser card assemblies. See “Replacing the riser card assembly” on page 147.
6. Press the metal shield that protects the AnyFabric adapter bay to the rear of the server to remove it. Store the shield in case that you later remove the AnyFabric adapter and need the shield to cover the bay.

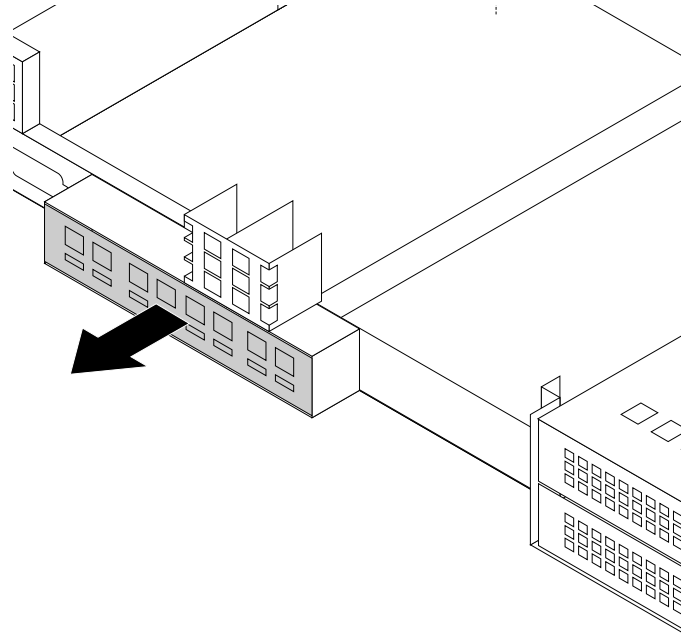

*Figure 61. Removing the protective shield for the AnyFabric adapter bay*

7. Touch the static-protective package that contains the AnyFabric adapter to any unpainted surface on the outside of the server. Then, take the AnyFabric adapter out of the package.

**Note:** Carefully handle the AnyFabric adapter by its edges.

8. Slide the AnyFabric adapter from the rear of the server to the front to connect the AnyFabric adapter to the AnyFabric adapter connector on the system board. Then, tighten the screw as shown to secure the AnyFabric adapter.

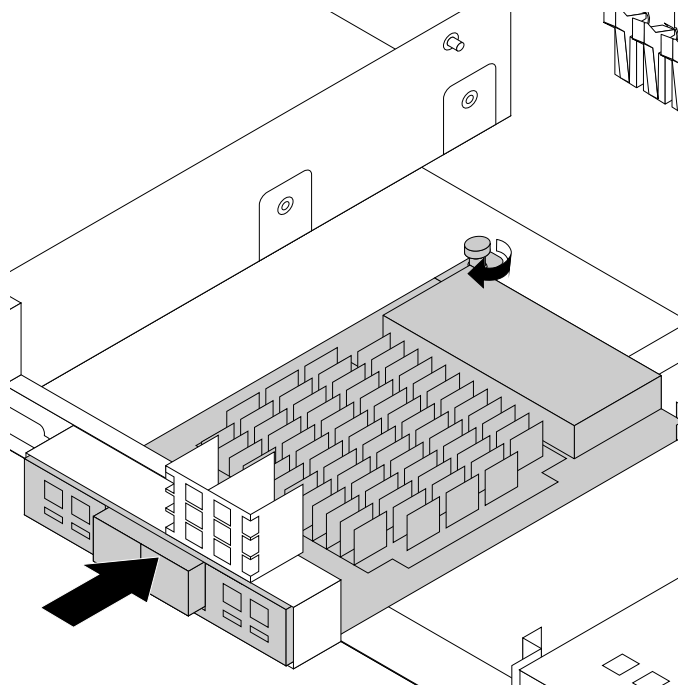

Figure 62. Installing the AnyFabric adapter

9. Reinstall the riser card assemblies. See “Replacing the riser card assembly” on page 147.

#### What to do next:

- To work with another piece of hardware, go to the appropriate section.
- To complete the installation, go to “Completing the parts replacement” on page 154.

### Removing the AnyFabric adapter

**Attention:** Do not open your server or attempt any repair before reading and understanding “Read this first: safety information” on page v and “Guidelines” on page 59.

Before you begin, print all the related instructions or ensure that you can view the PDF version on another computer for reference.

**Note:** Use any documentation that comes with the AnyFabric adapter and follow those instructions in addition to the instructions in this topic.

To remove the AnyFabric adapter, do the following:

1. Remove all external media from the drives and turn off all attached devices and the server. Then, disconnect all power cords from electrical outlets and disconnect all cables that are connected to the server.
2. Prepare your server. See “Removing or extending the server from the rack cabinet” on page 61.
3. Remove the server cover. See “Removing the server cover” on page 61.
4. Locate the AnyFabric adapter. See “Server components” on page 24.
5. Remove the riser card assemblies. See “Replacing the riser card assembly” on page 147.
6. Loosen the screw as shown and press the AnyFabric adapter to the rear of the server to disconnect the AnyFabric adapter from the system board. Then, remove the AnyFabric adapter from the rear of the server.



**Note:** Carefully handle the AnyFabric adapter by its edges.

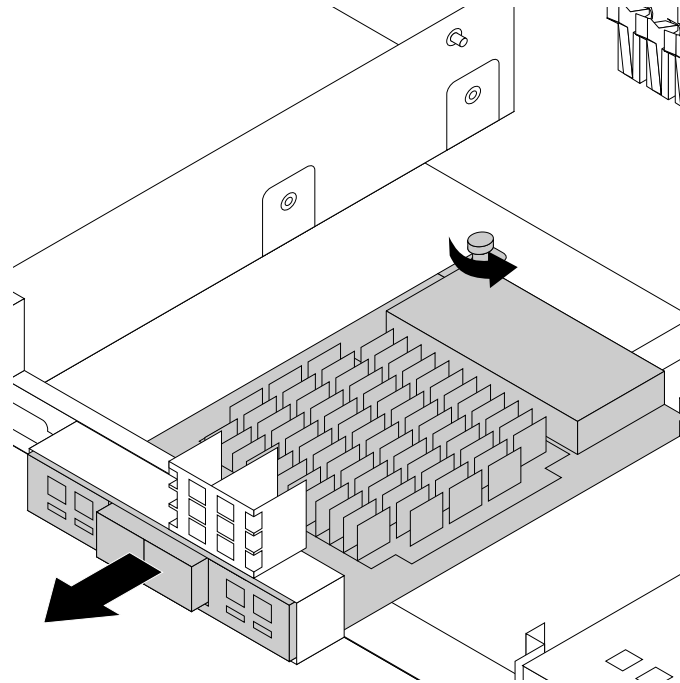

Figure 63. Removing the AnyFabric adapter

7. If you are instructed to return the old AnyFabric adapter, follow all packaging instructions and use any packaging materials that are supplied to you for shipping.
8. Reinstall the riser card assemblies. See “Replacing the riser card assembly” on page 147.

**What to do next:**

- To work with another piece of hardware, go to the appropriate section.
- To complete the removal procedure, go to “Completing the parts replacement” on page 154.

## Installing or removing the ThinkServer RAID Super Capacitor Module

The ThinkServer RAID Super Capacitor Module protects the cache memory on the installed ThinkServer RAID Adapter. You can purchase a ThinkServer RAID Super Capacitor Module from Lenovo.

For a list of ThinkServer options, go to:

<http://lenovoquickpick.com/usa/home/thinkserver/rack-and-tower-server>

### Installing the ThinkServer RAID Super Capacitor Module

**Attention:** Do not open your server or attempt any repair before reading and understanding “Read this first: safety information” on page v and “Guidelines” on page 59.

Before you begin, print all the related instructions or ensure that you can view the PDF version on another computer for reference.

**Notes:**

- You can install two ThinkServer RAID Super Capacitor Modules in your server.

- Use any documentation that comes with the ThinkServer RAID Super Capacitor Module and follow those instructions in addition to the instructions in this topic.

To install the ThinkServer RAID Super Capacitor Module, do the following:

1. Remove all external media from the drives and turn off all attached devices and the server. Then, disconnect all power cords from electrical outlets and disconnect all cables that are connected to the server.
2. Prepare your server. See “Removing or extending the server from the rack cabinet” on page 61.
3. Remove the server cover. See “Removing the server cover” on page 61.
4. Touch the static-protective package that contains the ThinkServer RAID Super Capacitor Module to any unpainted surface on the outside of the server. Then, take the ThinkServer RAID Super Capacitor Module out of the package.
5. Locate the place for installing the Super Capacitor Module in the server. See “Server components” on page 24.
6. Note the orientation of the ThinkServer RAID Super Capacitor Module. Then, lower the Super Capacitor Module and gently slide it until it is secured by the mounting studs on the chassis.

**Note:** Depending on your server model, refer to one of the following illustrations below.

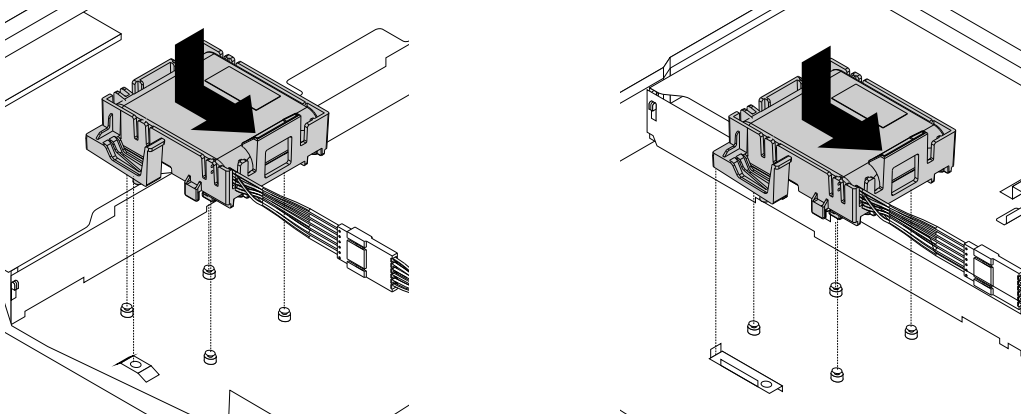

Figure 64. Installing the ThinkServer RAID Super Capacitor Module

7. Connect the ThinkServer RAID Super Capacitor Module to a RAID card.

**What to do next:**

- To work with another piece of hardware, go to the appropriate section.
- To complete the installation, go to “Completing the parts replacement” on page 154.

**Removing the ThinkServer RAID Super Capacitor Module**

**Attention:** Do not open your server or attempt any repair before reading and understanding “Read this first: safety information” on page v and “Guidelines” on page 59.

Before you begin, print all the related instructions or ensure that you can view the PDF version on another computer for reference.

**Note:** Use any documentation that comes with the ThinkServer RAID Super Capacitor Module and follow those instructions in addition to the instructions in this topic.

To remove the ThinkServer RAID Super Capacitor Module, do the following:

1. Remove all external media from the drives and turn off all attached devices and the server. Then, disconnect all power cords from electrical outlets and disconnect all cables that are connected to the server.
2. Prepare your server. See “Removing or extending the server from the rack cabinet” on page 61.
3. Remove the server cover. See “Removing the server cover” on page 61.
4. Disconnect the cable of the ThinkServer RAID Super Capacitor Module from the RAID card.
5. Gently lift the plastic tab **1** that secures the ThinkServer RAID Super Capacitor Module. Then, slide the ThinkServer RAID Super Capacitor Module as shown to completely remove it from the chassis.

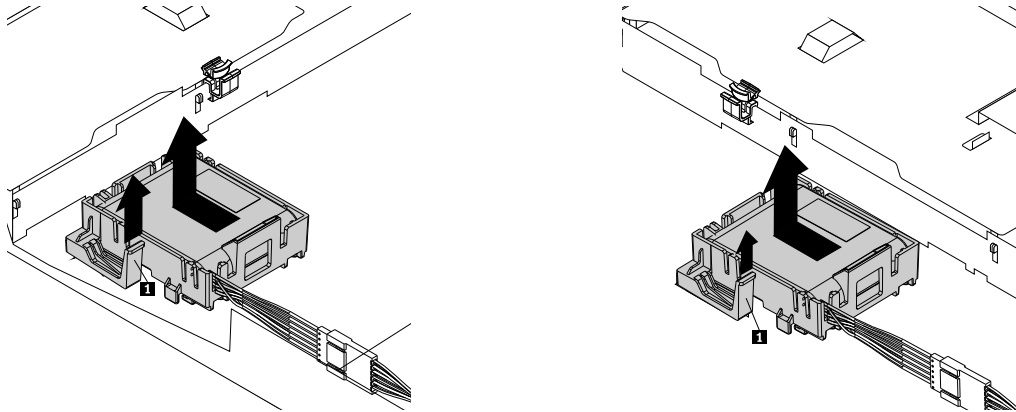

Figure 65. Removing the ThinkServer RAID Super Capacitor Module

6. If you are instructed to return the old ThinkServer RAID Super Capacitor Module, follow all packaging instructions and use any packaging materials that are supplied to you for shipping.

#### What to do next:

- To work with another piece of hardware, go to the appropriate section.
- To complete the removal procedure, go to “Completing the parts replacement” on page 154.

## Installing or removing a PCIe card

This topic provides instructions on how to install or remove a PCIe card, such as an Ethernet card, a RAID card, an interposer card, or any other supported PCIe cards.

#### Notes:

- The PCIe card is extremely sensitive to ESD. Ensure that you read and understand “Handling static-sensitive devices” on page 60 first and carefully perform the operation.
- The Lenovo ThinkServer RAID 520i PCIe Adapter and Lenovo ThinkServer RAID 720i PCIe Adapter only can be installed in PCIe slot 1 (the rightmost PCIe slot on the rear of the server). See “Rear view of the server” on page 21.

### Installing a PCIe card

**Attention:** Do not open your server or attempt any repair before reading and understanding “Read this first: safety information” on page v and “Guidelines” on page 59.

Before you begin, print all the related instructions or ensure that you can view the PDF version on another computer for reference.

To install a PCIe card on the riser card assembly, do the following:

1. Remove all external media from the drives and turn off all attached devices and the server. Then, disconnect all power cords from electrical outlets and disconnect all cables that are connected to the server.
2. Prepare your server. See “Removing or extending the server from the rack cabinet” on page 61.
3. Remove the server cover. See “Removing the server cover” on page 61.
4. Remove the riser card assembly on which you want to install the PCIe card. See “Replacing the riser card assembly” on page 147.
5. Locate an appropriate PCIe slot for installing the PCIe card and then pivot the card latch to the open position.

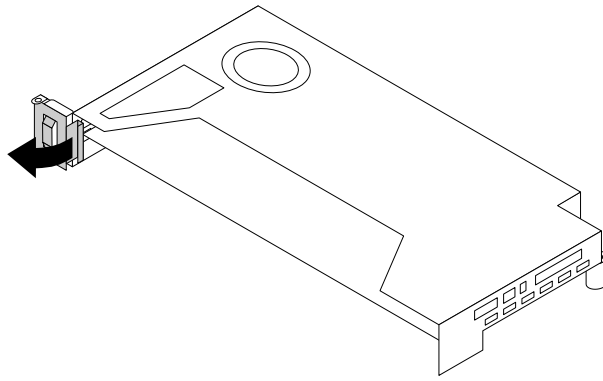

*Figure 66. Opening the PCIe card latch*

**Note:** If you are installing the ThinkServer RAID 720i PCIe Adapter, also remove the PCIe card holder. Press the clip as shown and remove the holder from the riser card assembly.

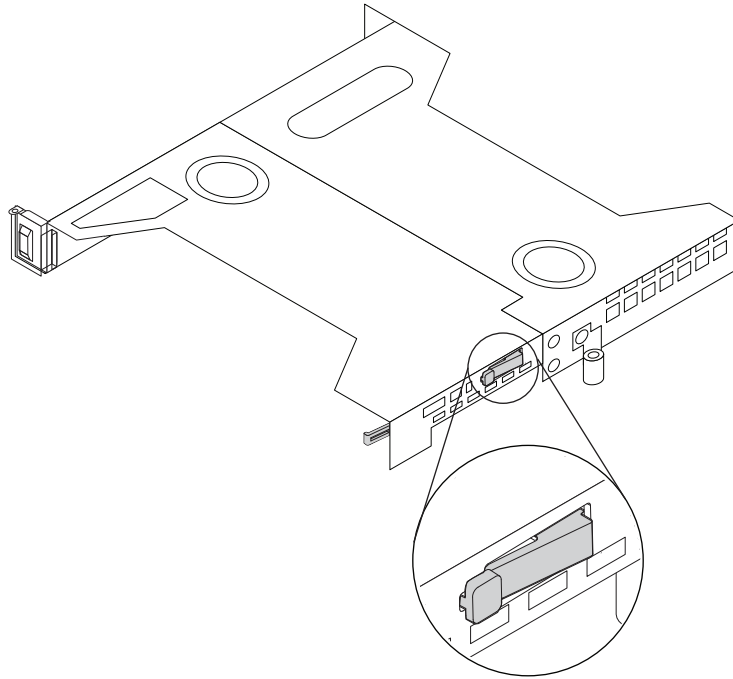

Figure 67. Removing the PCIe card holder

6. Remove the PCIe slot bracket from the riser card assembly. Store the bracket in case that you later remove the PCIe card and need the bracket to cover the place.

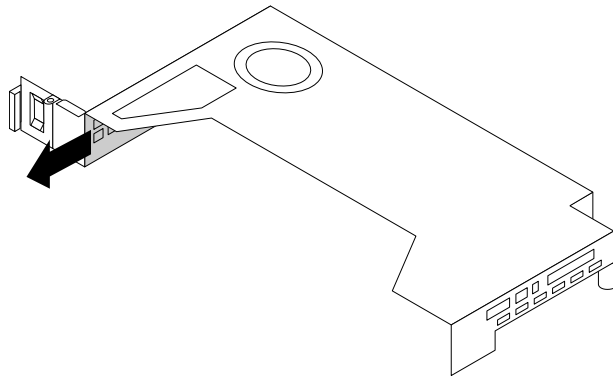

Figure 68. Removing a PCIe slot bracket

7. Touch the static-protective package that contains the PCIe card to any unpainted surface on the outside of the server. Then, take the PCIe card out of the package.

**Note:** Carefully handle the PCIe card by its edges.

8. Carefully press the PCIe card straight into the PCIe slot until it is securely seated.

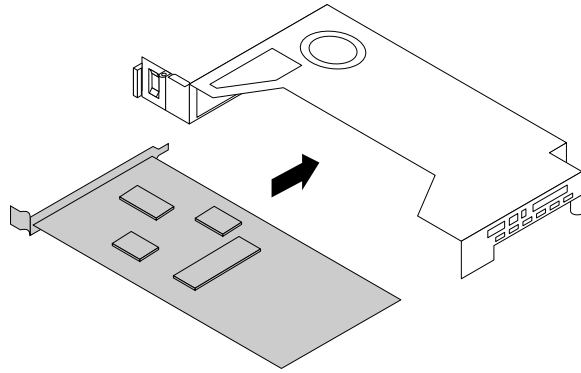

Figure 69. Installing a PCIe card

9. Pivot the card latch to the closed position to secure the PCIe card in position.

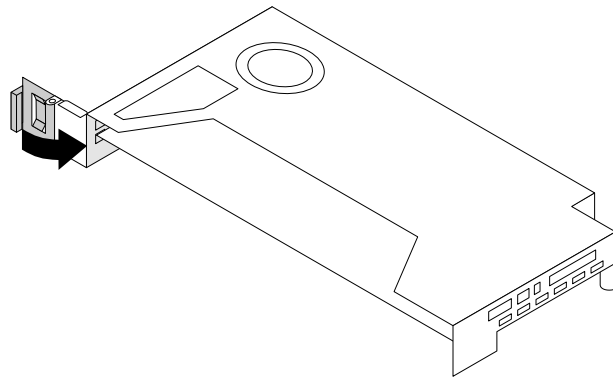

Figure 70. Pivoting the card latch to the closed position

10. Depending on the type of the PCIe card, you might need to connect any required cables. Refer to the documentation that comes with the PCIe card for specific information.
11. Reinstall the riser card assembly with the PCIe card to the system board. See “Replacing the riser card assembly” on page 147.

#### What to do next:

- To work with another piece of hardware, go to the appropriate section.
- To complete the installation, go to “Completing the parts replacement” on page 154. Then, continue with the following procedure to install the PCIe card driver if required.

#### Removing a PCIe card

**Attention:** Do not open your server or attempt any repair before reading and understanding “Read this first: safety information” on page v and “Guidelines” on page 59.

Before you begin, print all the related instructions or ensure that you can view the PDF version on another computer for reference.

To remove a PCIe card from the riser card assembly, do the following:

1. Remove all external media from the drives and turn off all attached devices and the server. Then, disconnect all power cords from electrical outlets and disconnect all cables that are connected to the server.

2. Prepare your server. See “Removing or extending the server from the rack cabinet” on page 61.
3. Remove the server cover. See “Removing the server cover” on page 61.
4. Remove the riser card assembly and lay it upside down on a flat, clean, and static-protective surface. See “Replacing the riser card assembly” on page 147.
5. Locate the PCIe card you want to remove. Then, pivot the card latch to the open position.

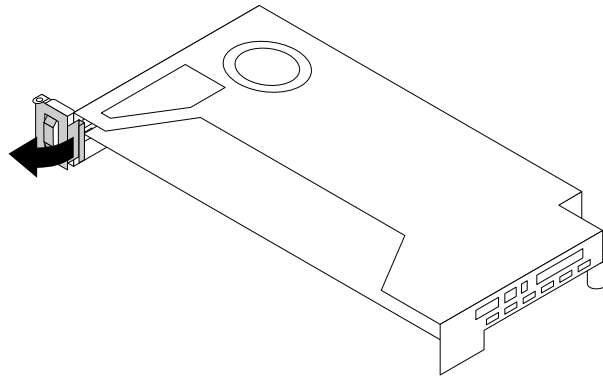

Figure 71. Pivoting the card latch to the open position

6. Grasp the PCIe card by its edges and carefully pull it out of the PCIe slot on the riser card assembly.

**Note:** The PCIe card might fit tightly into the PCIe slot. If necessary, alternate moving each side of the PCIe card a small and equal amount until it is completely removed from the slot.

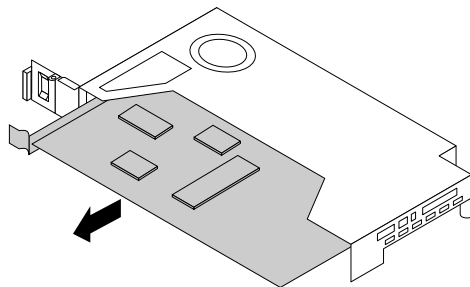

Figure 72. Removing the PCIe card

7. Install a new PCIe card to replace the old one or install a PCIe card slot bracket to cover the place. See “Installing a PCIe card” on page 93.
8. Reinstall the riser card assembly. See “Replacing the riser card assembly” on page 147.
9. If you are instructed to return the old PCIe card, follow all packaging instructions and use any packaging materials that are supplied to you for shipping.

**What to do next:**

- To work with another piece of hardware, go to the appropriate section.
- To complete the removal procedure, go to “Completing the parts replacement” on page 154.

## Installing or removing the serial port module

The serial port module provides a serial port for connecting compatible devices.

You can purchase a serial port module from Lenovo at:

## Installing the serial port module

**Attention:** Do not open your server or attempt any repair before reading and understanding “Read this first: safety information” on page v and “Guidelines” on page 59.

Before you begin, print all the related instructions or ensure that you can view the PDF version on another computer for reference.

**Note:** Use any documentation that comes with the serial port module and follow those instructions in addition to the instructions in this topic.

To install the serial port module, do the following:

1. Remove all external media from the drives and turn off all attached devices and the server. Then, disconnect all power cords from electrical outlets and disconnect all cables that are connected to the server.
2. Prepare your server. See “Removing or extending the server from the rack cabinet” on page 61.
3. Remove the server cover. See “Removing the server cover” on page 61.
4. Locate the PCIe slot for installing the serial port module. See “Rear view of the server” on page 21.
5. Remove the riser card assembly on which you want to install the serial port module. See “Replacing the riser card assembly” on page 147.
6. Pivot the card latch to the open position.

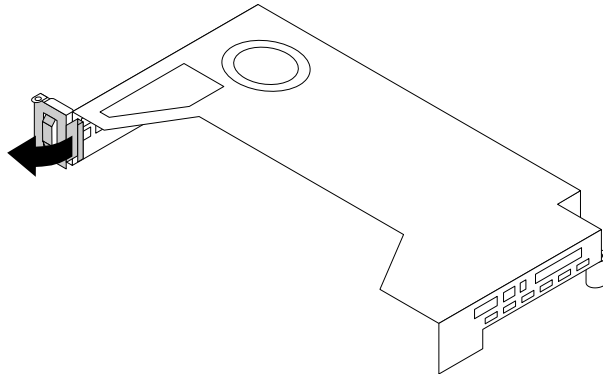

Figure 73. Opening the PCIe card latch

7. Remove the PCIe slot bracket from the riser card assembly. Store the bracket in case that you later remove the serial port module and need the bracket to cover the place.



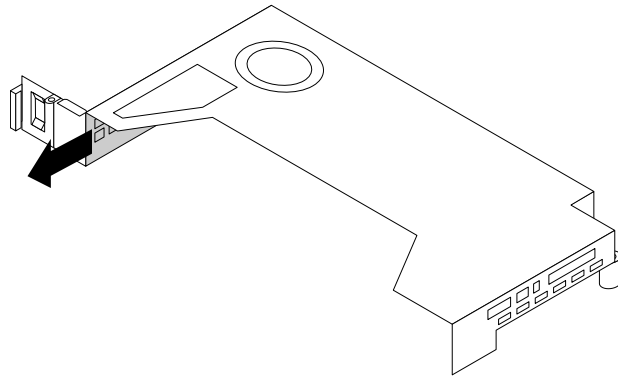

Figure 74. Removing a PCIe slot bracket

8. Carefully press the serial port module straight into the slot until it is securely seated.

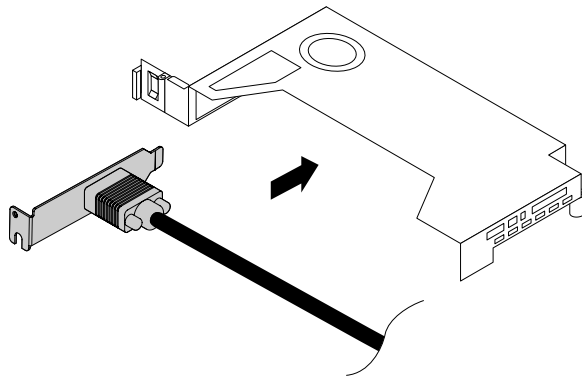

Figure 75. Installing the serial port module

9. Connect the cable of the serial port module to the serial-port-module connector on the system board. See “System board components” on page 35.
10. Pivot the card latch to the closed position to secure the serial port module in position.

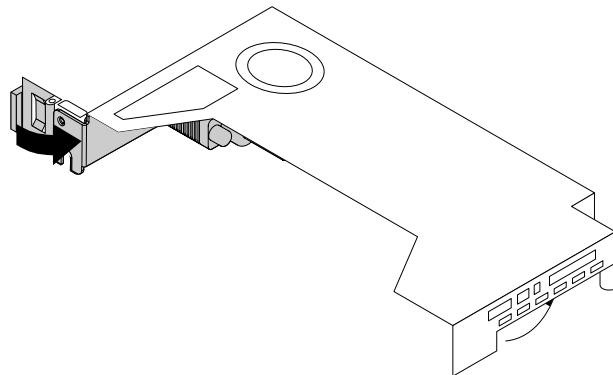

Figure 76. Pivoting the card latch to the closed position

11. Reinstall the riser card assembly with the serial port module to the system board. See “Replacing the riser card assembly” on page 147.

**What to do next:**

- To work with another piece of hardware, go to the appropriate section.
- To complete the installation, go to “Completing the parts replacement” on page 154. Then, continue with the following procedure to install the PCIe card driver if required.

## Removing the serial port module

**Attention:** Do not open your server or attempt any repair before reading and understanding “Read this first: safety information” on page v and “Guidelines” on page 59.

Before you begin, print all the related instructions or ensure that you can view the PDF version on another computer for reference.

**Note:** Use any documentation that comes with the serial port module and follow those instructions in addition to the instructions in this topic.

To remove the serial port module from the riser card assembly, do the following:

1. Remove all external media from the drives and turn off all attached devices and the server. Then, disconnect all power cords from electrical outlets and disconnect all cables that are connected to the server.
2. Prepare your server. See “Removing or extending the server from the rack cabinet” on page 61.
3. Remove the server cover. See “Removing the server cover” on page 61.
4. Locate the serial port module. See “Rear view of the server” on page 21.
5. Disconnect the serial-port-module cable from the system board.
6. Remove the riser card assembly installed with the serial port module and lay it upside down on a flat, clean, and static-protective surface. See “Replacing the riser card assembly” on page 147.
7. Pivot the card latch to the open position.

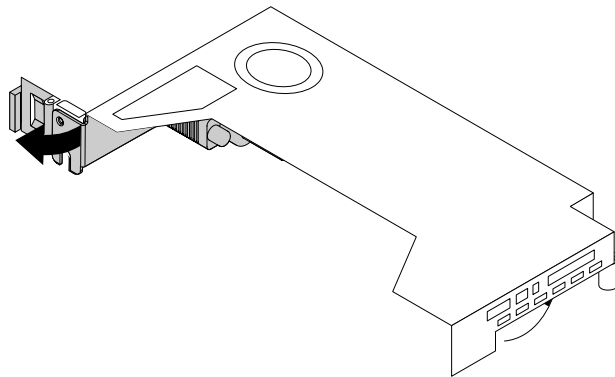

*Figure 77. Pivoting the card latch to the open position*

8. Pull the serial port module out of the PCIe slot on the riser card assembly.

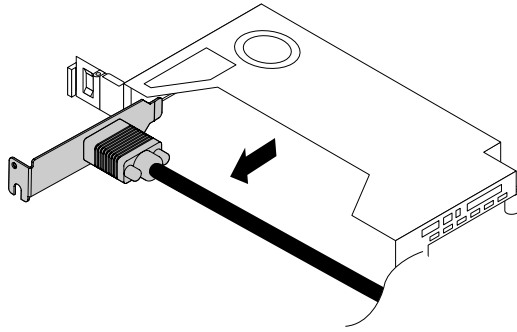

Figure 78. Removing the serial port module

9. Install a new serial port module, a PCIe card, or a slot bracket to cover the place. See “Installing a PCIe card” on page 93.
10. Reinstall the riser card assembly. See “Replacing the riser card assembly” on page 147.
11. If you are instructed to return the serial port module, follow all packaging instructions and use any packaging materials that are supplied to you for shipping.

**What to do next:**

- To work with another piece of hardware, go to the appropriate section.
- To complete the removal procedure, go to “Completing the parts replacement” on page 154.

## Installing or removing the optical module

The optical module enables you to connect two network devices with optical fiber cables. The optical module is needed only on some PCIe cards.

**Note:** The optical module is extremely sensitive to ESD. Ensure that you read and understand “Handling static-sensitive devices” on page 60 first and carefully perform the operation.

### Installing the optical module

**Attention:** Do not open your server or attempt any repair before reading and understanding “Read this first: safety information” on page v and “Guidelines” on page 59.

Before you begin, print all the related instructions or ensure that you can view the PDF version on another computer for reference.

**Notes:**

- The optical module and the PCIe card might look different from the illustration in this topic.
- Before you install the optical module, ensure that the PCIe card that requires the optical module is installed in the server. See “Installing a PCIe card” on page 93.

To install the optical module, do the following:

1. Locate the two holes at the rear of the PCIe card for installing the optical module.
2. Touch the static-protective package that contains the optical module to any unpainted surface on the outside of the server. Then, take the optical module out of the package.
3. With the optical module handle in the open position, insert the optical module into one of the two holes in the PCIe card.

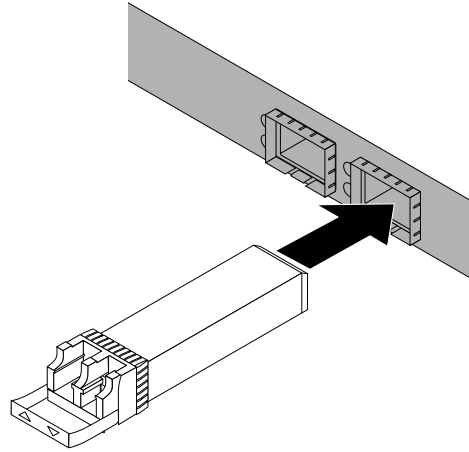

Figure 79. Installing the optical module

4. Pivot the optical module handle to the closed position to secure the optical module in place.

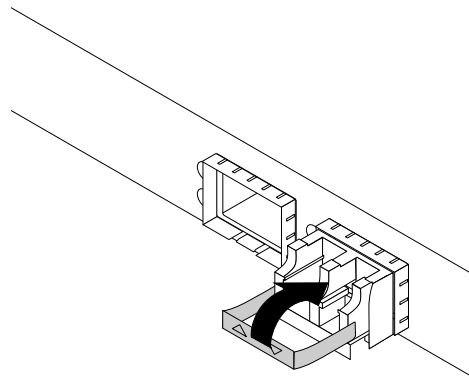

Figure 80. Pivoting the optical module handle to the closed position

**What to do next:**

- To work with another piece of hardware, go to the appropriate section.
- To complete the installation, go to “Completing the parts replacement” on page 154.

**Removing the optical module**

**Attention:** Do not open your server or attempt any repair before reading and understanding “Read this first: safety information” on page v and “Guidelines” on page 59.

Before you begin, print all the related instructions or ensure that you can view the PDF version on another computer for reference.

**Note:** The optical module and the PCIe card might look different from the illustration in this topic.

To remove the optical module, do the following:

1. Locate the optical module at the rear of your server.
2. Pivot the optical module handle to the open position.

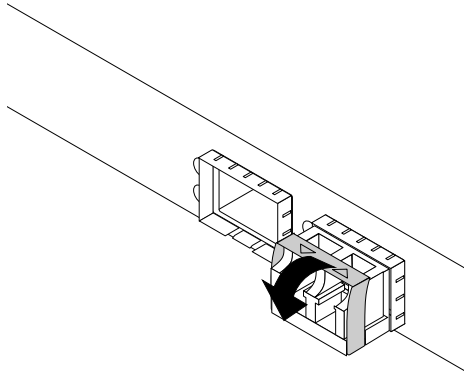

*Figure 81. Pivoting the optical module handle*

3. Gently pull the optical module out from the PCIe card.

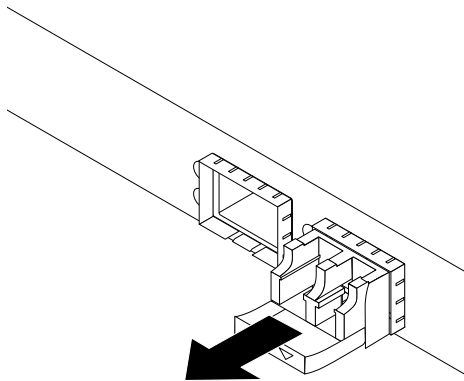

*Figure 82. Removing the optical module*

4. If you are instructed to return the old optical module, follow all packaging instructions and use any packaging materials that are supplied to you for shipping.

**What to do next:**

- To work with another piece of hardware, go to the appropriate section.
- To complete the removal procedure, go to “Completing the parts replacement” on page 154.

## Installing or removing the rear backplane/cage kit

The rear backplane/cage kit enables you to install up to two 2.5-inch hard disk drives for your server models with 3.5-inch drives. You can purchase a rear backplane/cage kit from Lenovo.

### Installing the rear backplane/cage kit

**Attention:** Do not open your server or attempt any repair before reading and understanding “Read this first: safety information” on page v and “Guidelines” on page 59.

Before you begin, print all the related instructions or ensure that you can view the PDF version on another computer for reference.

**Note:** Use any documentation that comes with the rear backplane/cage kit and follow those instructions in addition to the instructions in this topic.

To install the rear backplane/cage kit, do the following:

1. Remove all external media from the drives and turn off all attached devices and the server. Then, disconnect all power cords from electrical outlets and disconnect all cables that are connected to the server.
2. Prepare your server. See “Removing or extending the server from the rack cabinet” on page 61.
3. Remove the server cover. See “Removing the server cover” on page 61.
4. Locate the rear backplane/cage kit bay. See “Server components” on page 24.
5. Lift the metal shield that protects the rear backplane/cage kit bay. Store the shield in case that you later remove the kit and need the shield to cover the bay.

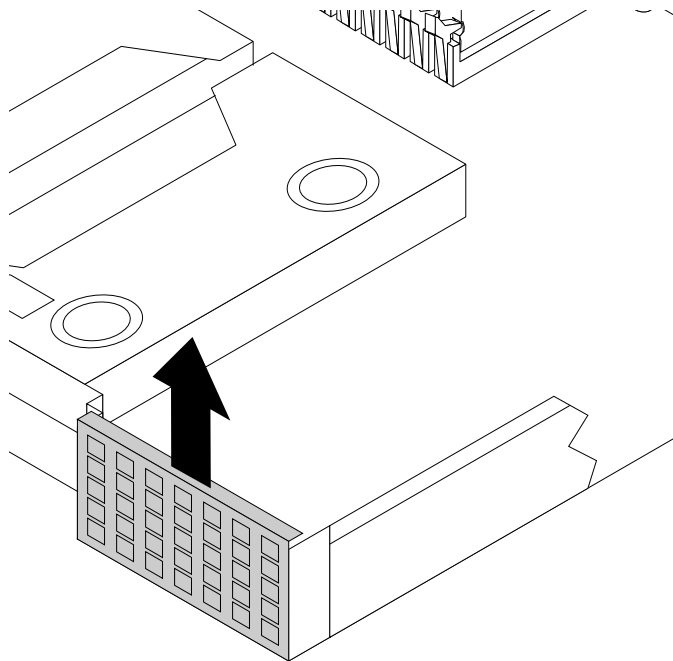

Figure 83. Removing the protective shield for the rear backplane/cage kit bay

6. Touch the static-protective package that contains the components of the rear backplane/cage kit to any unpainted surface on the outside of the server. Then, take the components out of the package.
7. Install the rear backplane to the cage. See “Replacing the rear backplane” on page 106.

- Slide the rear backplane/cage kit to the rear of the server so that the kit is engaged to the rear of the chassis. Align the two screws of the kit with the corresponding holes in the system board. Then, tighten the screws to secure the kit to the system board.

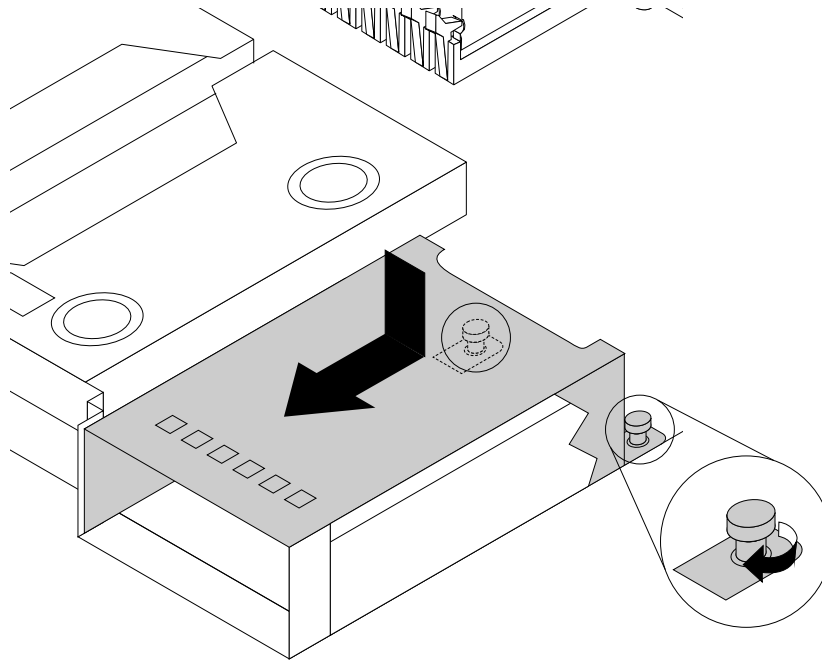

Figure 84. Installing the rear backplane/cage kit

- Install 2.5-inch hot-swap hard disk drives or dummy trays (if any) to the rear backplane/cage kit. See “Installing or replacing a hot-swap hard disk drive” on page 126.
- Connect cables to the rear backplane. See “Rear backplane for up to two 2.5-inch drives” on page 34.

#### What to do next:

- To work with another piece of hardware, go to the appropriate section.
- To complete the installation, go to “Completing the parts replacement” on page 154.

#### Removing the rear backplane/cage kit

**Attention:** Do not open your server or attempt any repair before reading and understanding “Read this first: safety information” on page v and “Guidelines” on page 59.

Before you begin, print all the related instructions or ensure that you can view the PDF version on another computer for reference.

**Note:** Use any documentation that comes with the rear backplane/cage kit and follow those instructions in addition to the instructions in this topic.

To remove the rear backplane/cage kit, do the following:

- Remove all external media from the drives and turn off all attached devices and the server. Then, disconnect all power cords from electrical outlets and disconnect all cables that are connected to the server.
- Prepare your server. See “Removing or extending the server from the rack cabinet” on page 61.
- Remove the server cover. See “Removing the server cover” on page 61.

4. Locate the rear backplane/cage kit. See “Server components” on page 24.
5. Remove the installed 2.5-inch hot-swap hard disk drives and dummy trays (if any) from the rear backplane/cage kit. See “Installing or replacing a hot-swap hard disk drive” on page 126.
6. Disconnect the cables from the rear backplane.
7. Loosen the screws and slide the rear backplane/cage kit to the front of the server to disengage it from the chassis. Then, lift the kit from the system board.

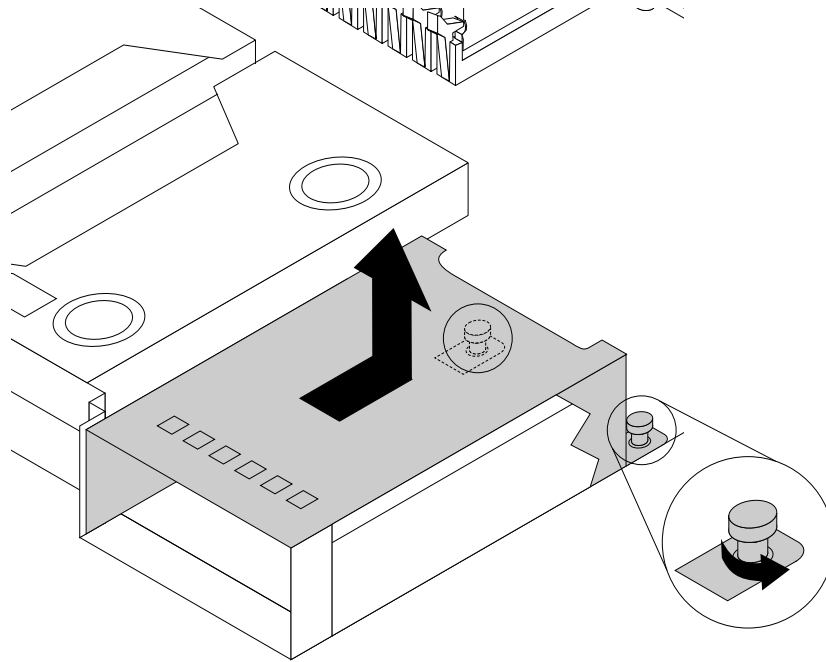

Figure 85. Removing the rear backplane/cage kit

8. If you are instructed to return the old rear backplane/cage kit, follow all packaging instructions and use any packaging materials that are supplied to you for shipping.

#### What to do next:

- To work with another piece of hardware, go to the appropriate section.
- To complete the removal procedure, go to “Completing the parts replacement” on page 154.

## Replacing the rear backplane

**Attention:** Do not open your server or attempt any repair before reading and understanding “Read this first: safety information” on page v and “Guidelines” on page 59.

Before you begin, print all the related instructions or ensure that you can view the PDF version on another computer for reference.

To replace the rear backplane, do the following:

1. Remove all external media from the drives and turn off all attached devices and the server. Then, disconnect all power cords from electrical outlets and disconnect all cables that are connected to the server.
2. Prepare your server. See “Removing or extending the server from the rack cabinet” on page 61.



3. Remove all the installed hot-swap hard disk drives and dummy trays (if any) from the rear backplane/cage kit. See “Installing or replacing a hot-swap hard disk drive” on page 126.
4. Record the cable routing and cable connections and then disconnect cables from the rear backplane.
5. Remove the rear backplane/cage kit. See “Removing the rear backplane/cage kit” on page 105.
6. Remove the two screws that secure the backplane to the cage. Then, lift the backplane from the cage.

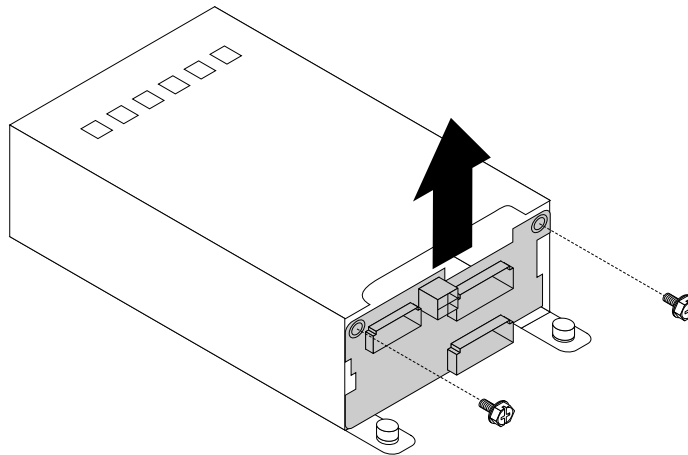

Figure 86. Removing the rear backplane

7. Touch the static-protective package that contains the new rear backplane to any unpainted surface on the outside of the server. Then, remove the new backplane from the package.

**Note:** Carefully handle the backplane by its edges.

8. Note the orientation of the new backplane. Align the screw holes in the new backplane with the corresponding ones in the cage. Then, install the two screws to secure the backplane.

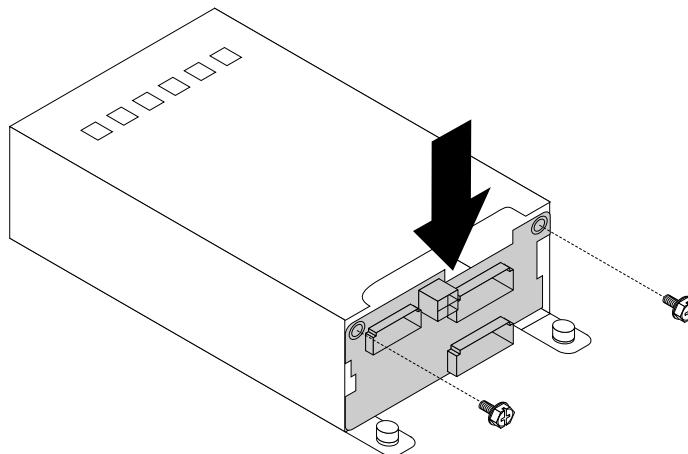

Figure 87. Installing the rear backplane

9. Install the rear backplane/cage kit to the chassis. See “Installing the rear backplane/cage kit” on page 104.
10. Reinstall all the hot-swap hard disk drives and dummy trays (if any) in the rear backplane/cage kit. See “Installing or replacing a hot-swap hard disk drive” on page 126.
11. Refer to your note to connect the cables to the new backplane.

12. If you are instructed to return the old backplane, follow all packaging instructions and use any packaging materials that are supplied to you for shipping.

**What to do next:**

- To work with another piece of hardware, go to the appropriate section.
- To complete the replacement, go to “Completing the parts replacement” on page 154.

## Replacing the AnyRAID adapter

**Attention:** Do not open your server or attempt any repair before reading and understanding “Read this first: safety information” on page v and “Guidelines” on page 59.

Before you begin, print all the related instructions or ensure that you can view the PDF version on another computer for reference.

**Notes:**

- Use any documentation that comes with the new AnyRAID adapter and follow those instructions in addition to the instructions in this topic.
- Depending on the model, your AnyRAID adapter might look different from the illustrations in this topic.

To replace the AnyRAID adapter, do the following:

1. Remove all external media from the drives and turn off all attached devices and the server. Then, disconnect all power cords from electrical outlets and disconnect all cables that are connected to the server.
2. Prepare your server. See “Removing or extending the server from the rack cabinet” on page 61.
3. Remove the server cover. See “Removing the server cover” on page 61.
4. Locate the AnyRAID adapter. See “Server components” on page 24.
5. Loosen the two screws and grasp the AnyRAID adapter by its edges and carefully pull it out.

**Note:** The AnyRAID adapter might fit tightly into the slot. If necessary, alternate moving each side of the AnyRAID adapter a small and equal amount until it is removed from the slots.

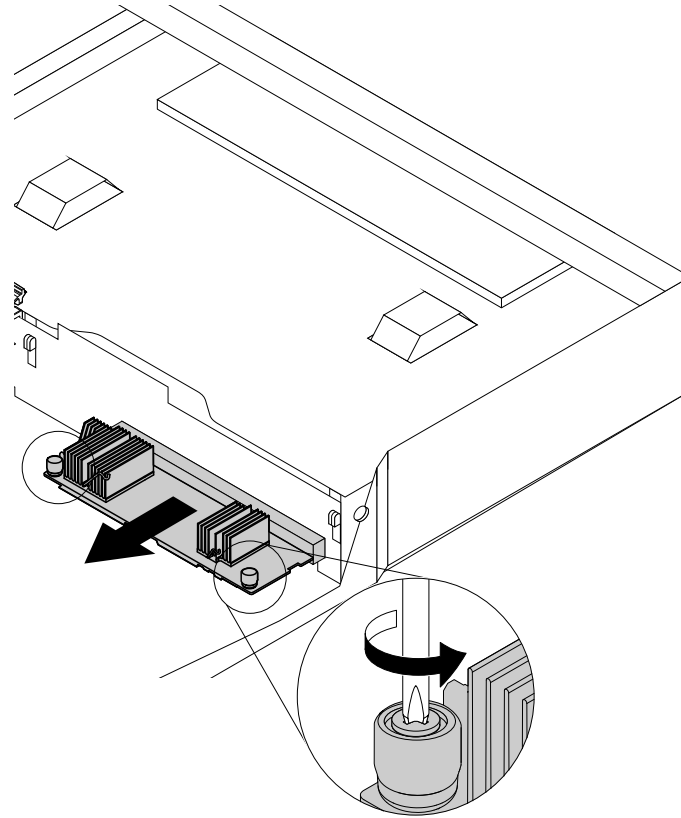

Figure 88. Removing the AnyRAID adapter

6. Touch the static-protective package that contains the new AnyRAID adapter to any unpainted surface on the outside of the server. Then, take the new AnyRAID adapter out of the package.

**Note:** Carefully handle the AnyRAID adapter by its edges.

7. Position the new AnyRAID adapter near the backplane. Then, gently press the AnyRAID adapter straight into the AnyRAID adapter slot until it is securely seated.

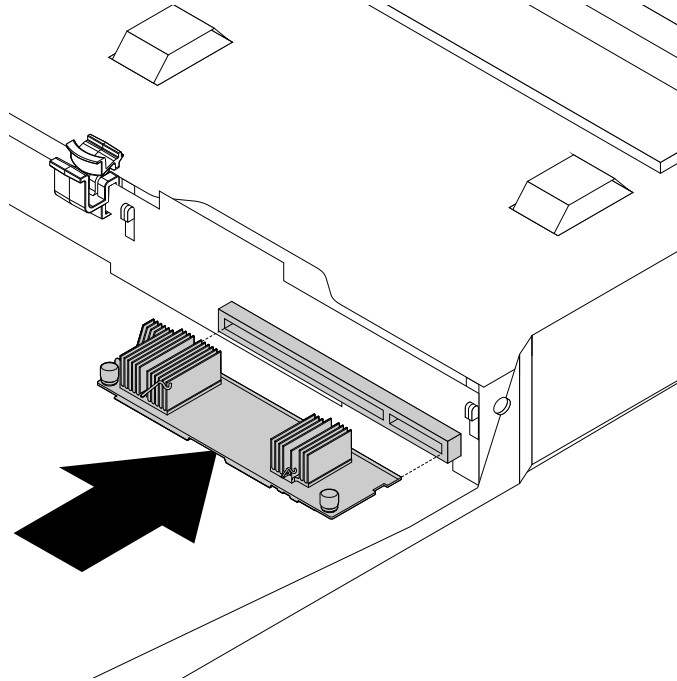

Figure 89. Installing the AnyRAID adapter

8. Tighten the two screws to secure the AnyRAID adapter.

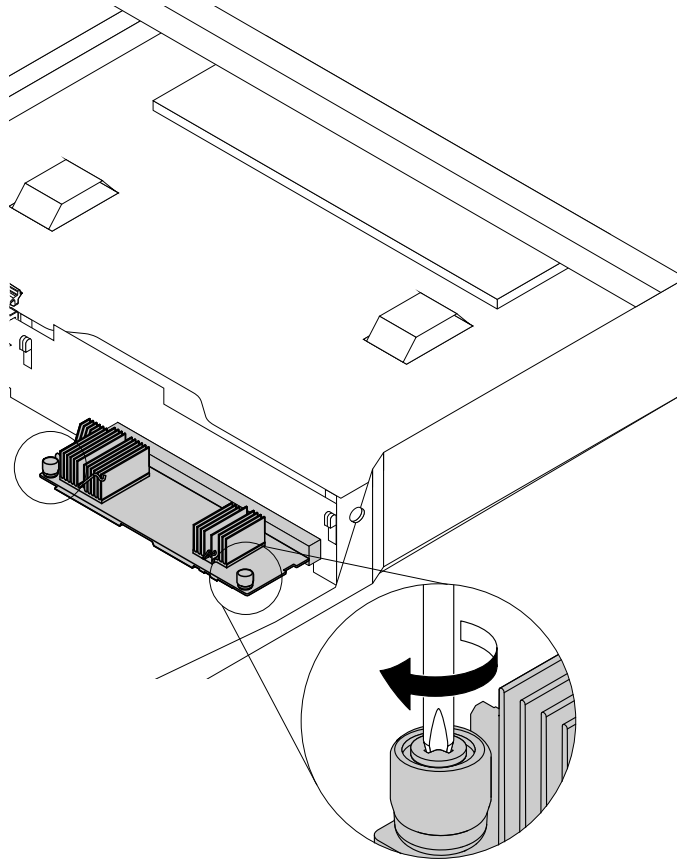

Figure 90. Tightening the screws

9. If you are instructed to return the old AnyRAID adapter, follow all packaging instructions and use any packaging materials that are supplied to you for shipping.

**What to do next:**

- To work with another piece of hardware, go to the appropriate section.
- To complete the replacement, go to “Completing the parts replacement” on page 154.

## Installing or removing the intrusion switch

The intrusion switch informs you that the server cover is not properly installed or closed by creating an event in the system event log (SEL). You can purchase an intrusion switch from Lenovo.

### Installing the intrusion switch

**Attention:** Do not open your server or attempt any repair before reading and understanding “Read this first: safety information” on page v and “Guidelines” on page 59.

Before you begin, print all the related instructions or ensure that you can view the PDF version on another computer for reference.

**Note:** Use any documentation that comes with the intrusion switch and follow those instructions in addition to the instructions in this topic.

To install the intrusion switch, do the following:

1. Remove all external media from the drives and turn off all attached devices and the server. Then, disconnect all power cords from electrical outlets and disconnect all cables that are connected to the server.
2. Prepare your server. See “Removing or extending the server from the rack cabinet” on page 61.
3. Remove the server cover. See “Removing the server cover” on page 61.
4. Touch the static-protective package that contains the intrusion switch to any unpainted surface on the outside of the server. Then, take the intrusion switch out of the package.
5. Press the tab  outward as shown and then lower the intrusion switch until it is secured in the socket.

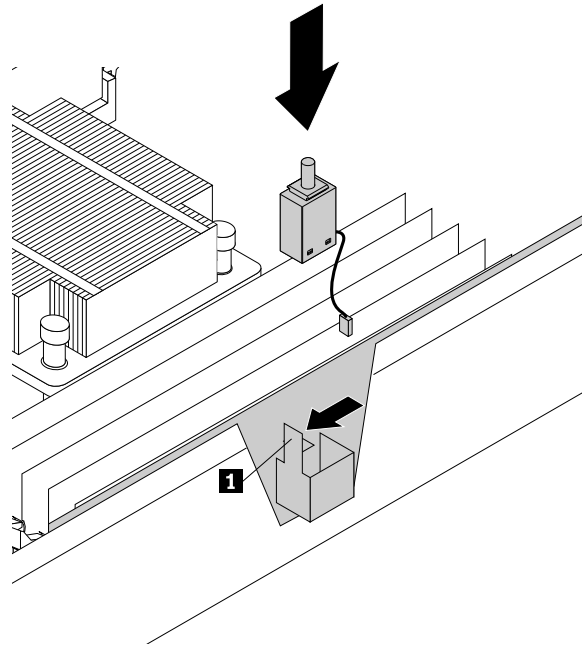

Figure 91. Installing the intrusion switch

6. Connect the intrusion switch cable to the intrusion switch connector on the system board. See “System board components” on page 35.

**What to do next:**

- To work with another piece of hardware, go to the appropriate section.
- To complete the installation, go to “Completing the parts replacement” on page 154.

### Removing the intrusion switch

**Attention:** Do not open your server or attempt any repair before reading and understanding “Read this first: safety information” on page v and “Guidelines” on page 59.

Before you begin, print all the related instructions or ensure that you can view the PDF version on another computer for reference.

**Notes:**

- If you remove the intrusion switch, you will not get the warning message when logging in to your server with the cover removed.
- Use any documentation that comes with the intrusion switch and follow those instructions in addition to the instructions in this topic.

To remove the intrusion switch, do the following:

1. Remove all external media from the drives and turn off all attached devices and the server. Then, disconnect all power cords from electrical outlets and disconnect all cables that are connected to the server.
2. Prepare your server. See “Removing or extending the server from the rack cabinet” on page 61.
3. Remove the server cover. See “Removing the server cover” on page 61.
4. Locate the intrusion switch and disconnect the cable from the system board.

5. Press the tab **1** outward and lift the intrusion switch out of the socket.

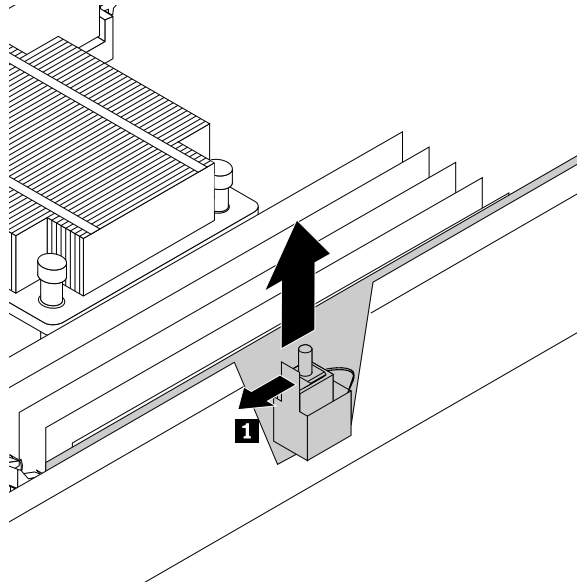

Figure 92. Removing the intrusion switch

6. If you are instructed to return the old intrusion switch, follow all packaging instructions and use any packaging materials that are supplied to you for shipping.

#### What to do next:

- To work with another piece of hardware, go to the appropriate section.
- To complete the removal procedure, go to “Completing the parts replacement” on page 154.

## Installing or replacing a heat sink

**Attention:** Do not open your server or attempt any repair before reading and understanding “Read this first: safety information” on page v and “Guidelines” on page 59.

Before you begin, print all the related instructions or ensure that you can view the PDF version on another computer for reference.

#### CAUTION:



**The heat sink might be very hot. Turn off the server and wait several minutes to let the server cool before removing the server cover.**

**Note:** Use any documentation that comes with the heat sink and follow those instructions in addition to the instructions in this topic.

To install or replace a heat sink, do the following:

1. Remove all external media from the drives and turn off all attached devices and the server. Then, disconnect all power cords from electrical outlets and disconnect all cables that are connected to the server.

2. Prepare your server. See “Removing or extending the server from the rack cabinet” on page 61.
3. Remove the server cover. See “Removing the server cover” on page 61.
4. Remove the cooling shroud. See “Removing and reinstalling the cooling shroud” on page 64.
5. Locate the heat sink you want to replace or the place for installing the second heat sink. See “Server components” on page 24.
6. If you are replacing a heat sink, remove the four screws that secure the heat sink to the system board. It is recommended that you carefully remove the four screws from the system board using the following method to avoid any possible damage to the system board.
  - a. Partially remove screw **1**, then completely remove screw **3**, and then return to screw **1** and completely remove it.
  - b. Partially remove screw **2**, then completely remove screw **4**, and then return to screw **2** and completely remove it.

**Note:** The four screws are integrated parts of the heat sink. Do not try to remove the four screws from the heat sink.

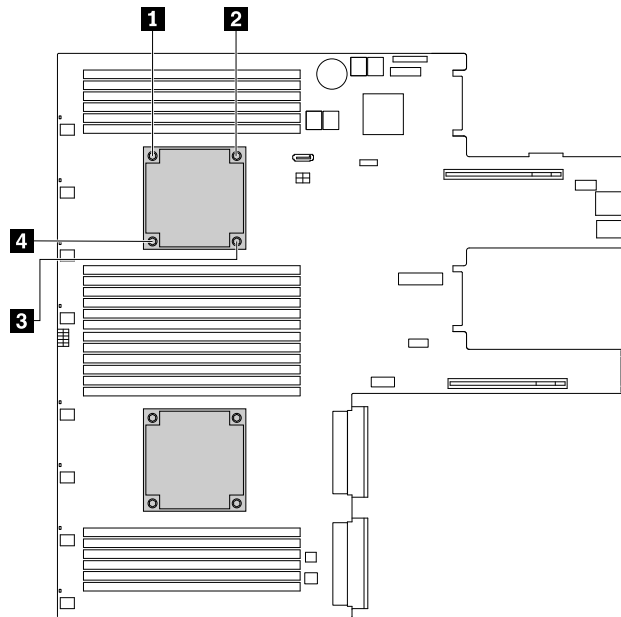

Figure 93. Removing the heat sink

7. Gently twist the heat sink to free it from the microprocessor and then lift the heat sink off the system board.
8. Lay aside the old heat sink. Touch the static-protective package that contains the new heat sink to any unpainted surface on the outside of the server. Then, take the new heat sink out of the package.

**Notes:**

- If you are replacing a heat sink, use a cleaning pad that might come with the new heat sink to wipe the thermal grease from the top of the microprocessor before installing the new heat sink. Dispose of the cleaning pad after all of the thermal grease is removed from the microprocessor.
  - When handling the new heat sink, do not touch the thermal grease on the bottom of it.
9. Remove any protective cover that protects the thermal grease on the bottom of the new heat sink. Then, place the new heat sink on the system board so that the four screws on the new heat sink are aligned with the corresponding mounting studs on the system board.



10. Install the four screws to secure the new heat sink on the system board. It is recommended that you carefully install the four screws using the following method to avoid any possible damage to the system board.
  - a. Partially tighten screw **1**, then firmly tighten screw **3**, and then return to screw **1** and firmly tighten it. Do not over-tighten the screws.
  - b. Partially tighten screw **2**, then firmly tighten screw **4**, and then return to screw **2** and firmly tighten it. Do not over-tighten the screws.

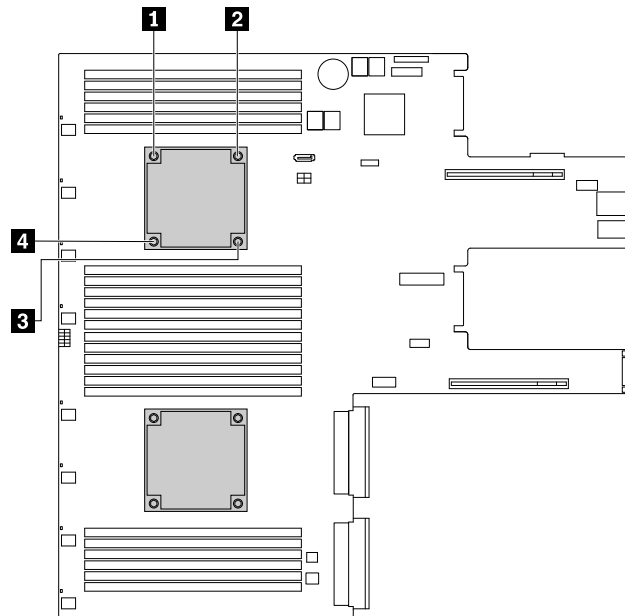

Figure 94. Installing the screws to secure the heat sink

11. If you are instructed to return the old heat sink, follow all packaging instructions and use any packaging materials that are supplied to you for shipping.

#### What to do next:

- To work with another piece of hardware, go to the appropriate section.
- To complete the installation or replacement, go to “Completing the parts replacement” on page 154.

## Installing or replacing the microprocessor

This topic provides instructions on how to install or replace the microprocessor.

### Installing the second microprocessor

**Attention:** Do not open your server or attempt any repair before reading and understanding “Read this first: safety information” on page v and “Guidelines” on page 59.

Depending on the model, your server might come with one or two microprocessors. For server models with one microprocessor, the microprocessor is installed in the microprocessor socket 1 and the microprocessor socket 2 is protected by a plastic socket cover. You can purchase a microprocessor option kit from Lenovo and install the second microprocessor to expand system capabilities.

Before you begin, print all the related instructions or ensure that you can view the PDF version on another computer for reference.

**CAUTION:**



**The heat sinks and microprocessors might be very hot. Turn off the server and wait several minutes to let the server cool before removing the server cover.**

**Notes:**

- Ensure that you install the correct type of microprocessor option your server supports. See “Features” on page 7. When two microprocessors are installed, both must have the same core voltage and core speed.
- Use any documentation that comes with the microprocessor option kit and follow those instructions in addition to the instructions in this topic.
- Your microprocessor, socket, and socket cover might look slightly different from the illustrations in this topic.

To install the second microprocessor, do the following:

1. Remove all external media from the drives and turn off all attached devices and the server. Then, disconnect all power cords from electrical outlets and disconnect all cables that are connected to the server.
2. Prepare your server. See “Removing or extending the server from the rack cabinet” on page 61.
3. Remove the server cover. See “Removing the server cover” on page 61.
4. Remove the cooling shroud. See “Removing and reinstalling the cooling shroud” on page 64.
5. Locate the microprocessor socket 2 on the system board. See “System board components” on page 35.
6. Open the small handle **1** first by gently pressing down the handle a little bit and then pushing the handle inward to release it from the secured position. Then, open the other small handle **2** in the same way.

**Note:** There are two marks on the microprocessor retainer. Open the small handle marked with **1** first and then open the other small handle marked with **2**. Always follow the correct sequence when you open the small handles.

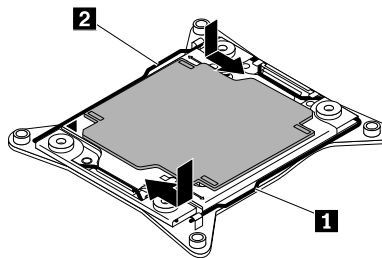

*Figure 95. Opening the handles*

7. Gently press the microprocessor retainer to open it. Ensure that the small handles and the microprocessor retainer are in the fully open position.

**Note:** Do not drop anything onto the microprocessor socket while it is exposed. The socket pins must be kept as clean as possible.

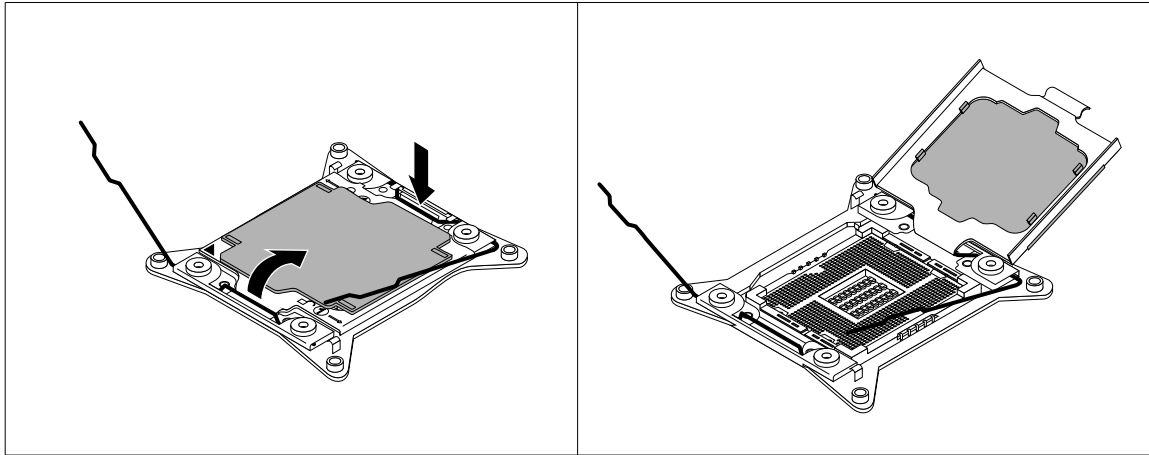

Figure 96. Opening the microprocessor retainer

8. Touch the static-protective package that contains the new microprocessor to any unpainted surface on the outside of the server. Then, remove the new microprocessor from the package.
9. Remove the new microprocessor from the protective cover that protects the gold contacts on the bottom of the new microprocessor. Do not touch the pins on the microprocessor socket and the gold contacts on the bottom of the new microprocessor.

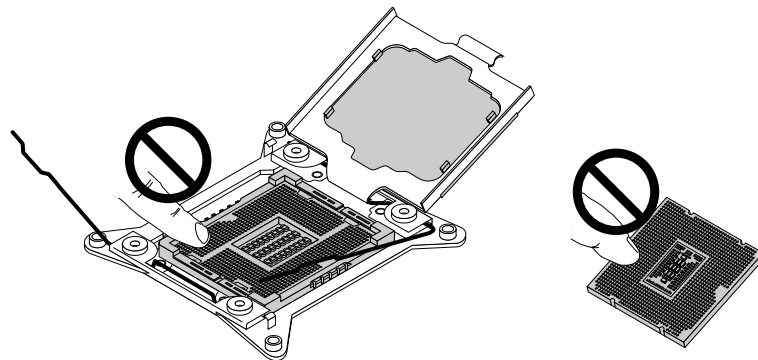

Figure 97. Do not touch the pins

10. Note the orientation of the new microprocessor. Hold the new microprocessor by its edges and align the notches **1** on it with the tabs **2** in the microprocessor socket. Then, carefully lower the new microprocessor straight down into the microprocessor socket.

**Note:** The small triangle **3** on one corner of the new microprocessor is the microprocessor orientation indicator. The new microprocessor is in the correct orientation when this indicator faces the beveled corner **4** of the microprocessor socket.

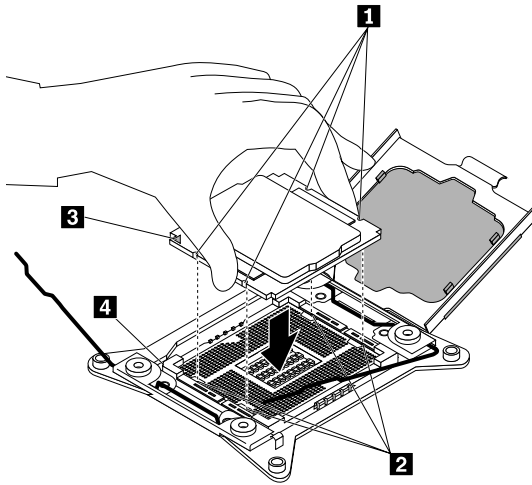

Figure 98. Installing the microprocessor

11. Remove the plastic microprocessor socket cover. Store the microprocessor socket cover in case that you later remove the microprocessor and need the socket cover to protect the pins on the socket.

**Note:** Do not remove the socket cover until you install a microprocessor into the socket. If you remove the microprocessor, install the socket cover or a new microprocessor immediately.

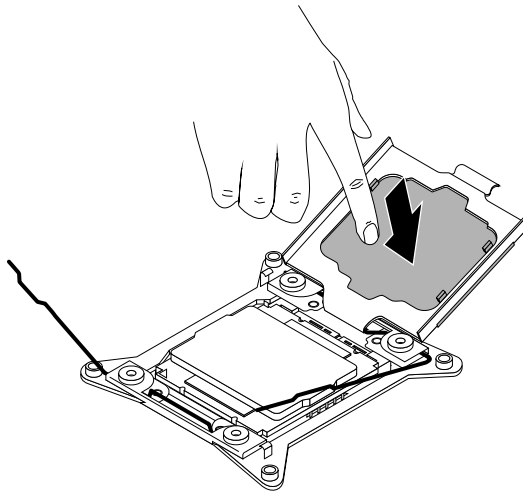

Figure 99. Removing the microprocessor socket cover

12. Close the microprocessor retainer. Then, close the small handle **1** first and then close the small handle **2** to lock the retainer into position and secure the new microprocessor in the socket.

**Note:** There are two marks on the microprocessor retainer. Open the small handle marked with **1** first and then open the other small handle marked with **2**. Always follow the correct sequence when you open the small handles.

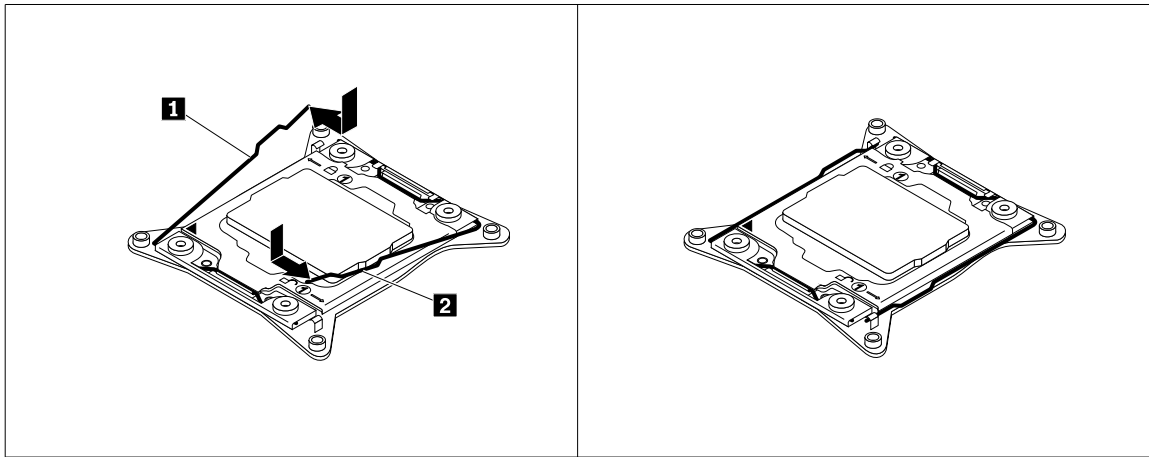

Figure 100. Securing the microprocessor in the socket

13. Install the new heat sink that comes with the microprocessor option kit. See “Installing or replacing a heat sink” on page 113.

**What to do next:**

- To work with another piece of hardware, go to the appropriate section.
- To complete the installation, go to “Completing the parts replacement” on page 154.

**Replacing the microprocessor**

**Attention:** Do not open your server or attempt any repair before reading and understanding “Read this first: safety information” on page v and “Guidelines” on page 59.

**CAUTION:**



**The heat sink and microprocessor might be very hot. Turn off the server and wait several minutes to let the server cool before removing the server cover.**

Before you begin, print all the related instructions or ensure that you can view the PDF version on another computer for reference.

**Notes:**

- Ensure that the new microprocessor is the correct type your server supports. See “Memory module installation rules” on page 66. When two microprocessors are installed, both must have the same core voltage and core speed.
- Use any documentation that comes with the microprocessor option kit and follow those instructions in addition to the instructions in this topic.
- Your microprocessor, socket, and socket cover might look slightly different from the illustrations in this topic.

To replace the microprocessor, do the following:

1. Remove all external media from the drives and turn off all attached devices and the server. Then, disconnect all power cords from electrical outlets and disconnect all cables that are connected to the server.

2. Prepare your server. See “Removing or extending the server from the rack cabinet” on page 61.
3. Remove the server cover. See “Removing the server cover” on page 61.
4. Remove the cooling shroud. See “Removing and reinstalling the cooling shroud” on page 64.
5. Remove the heat sink. See “Installing or replacing a heat sink” on page 113.
6. Locate the microprocessor socket. Open the small handle **1** first by gently pressing down the handle a little bit and then pushing the handle inward to release it from the secured position. Then, open the other small handle **2** in the same way.

**Note:** There are two marks on the microprocessor retainer. Open the small handle marked with **1** first and then open the other small handle marked with **2**. Always follow the correct sequence when you open the small handles.

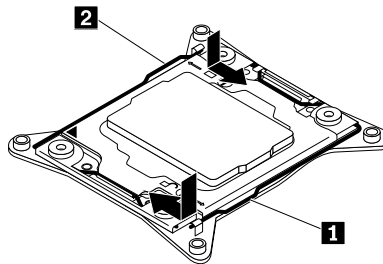

Figure 101. Opening the handles

7. Gently press the microprocessor retainer as shown to open it. Ensure that the small handles and the microprocessor retainer are in the fully open position.

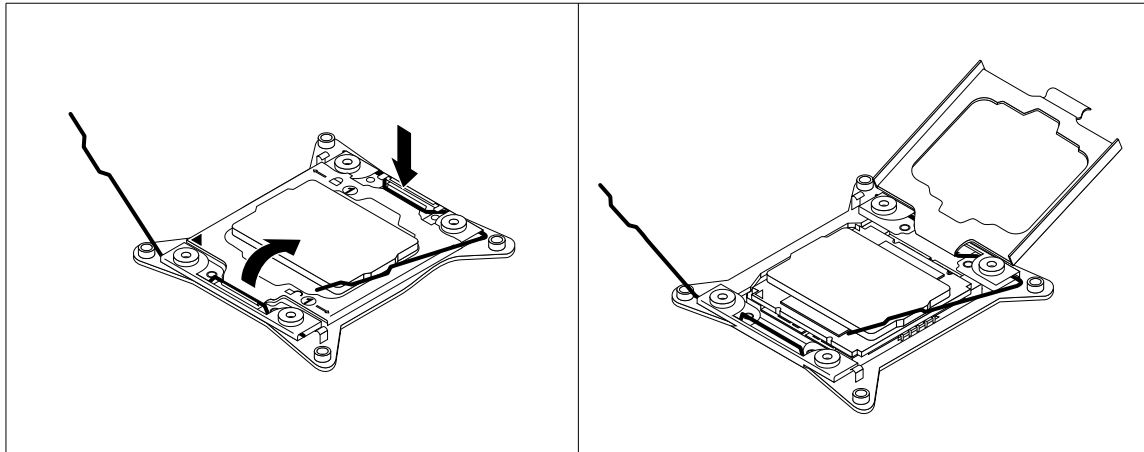

Figure 102. Opening the microprocessor retainer

8. Touch only the edges of the microprocessor and carefully lift it straight up and out of the microprocessor socket. Place the old microprocessor on a static-protective surface.

**Notes:**

- a. Do not touch the gold contacts on the bottom of the microprocessor.
- b. Do not drop anything onto the microprocessor socket while it is exposed. The socket pins must be kept as clean as possible.

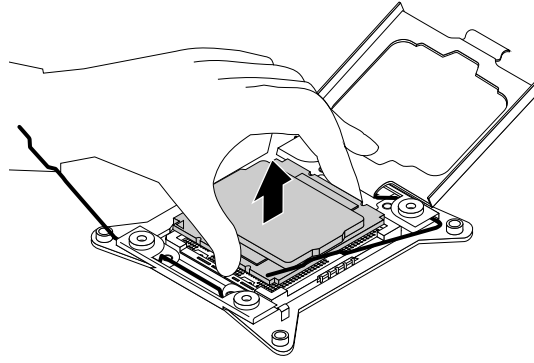

Figure 103. Removing the microprocessor

9. Touch the static-protective package that contains the new microprocessor to any unpainted surface on the outside of the server. Then, remove the new microprocessor from the package.
10. Remove the new microprocessor from the protective cover that protects the gold contacts on the bottom of the new microprocessor. Do not touch the pins on the microprocessor socket and the gold contacts on the bottom of the new microprocessor.

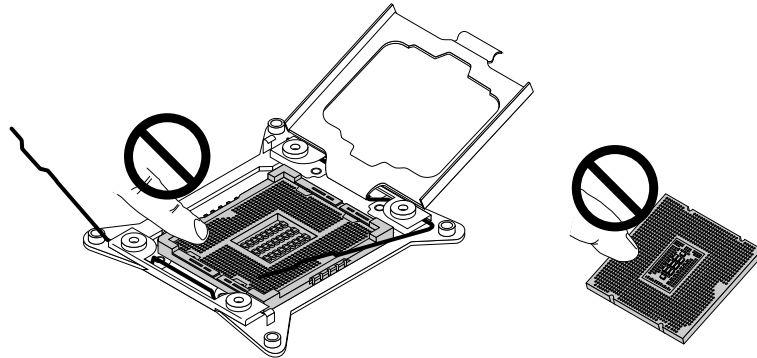

Figure 104. Do not touch the pins

11. Note the orientation of the new microprocessor. Hold the new microprocessor by its edges and align the notches **1** on it with the tabs **2** in the microprocessor socket. Then, carefully lower the new microprocessor straight down into the microprocessor socket.

**Note:** The small triangle **3** on one corner of the new microprocessor is the microprocessor orientation indicator. The new microprocessor is in the correct orientation when this indicator faces the beveled corner **4** of the microprocessor socket.

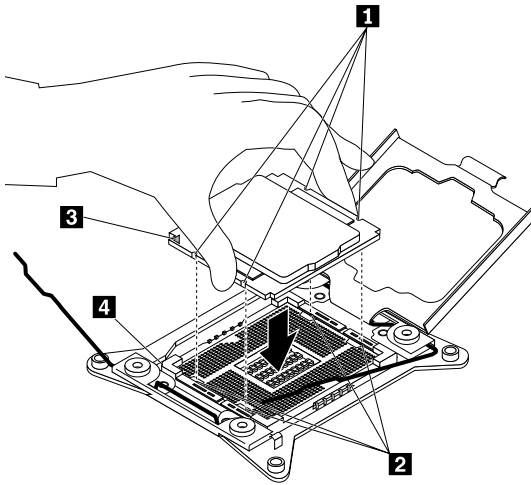

Figure 105. Installing the microprocessor

12. Close the microprocessor retainer. Close the small handle **1** first. Then, close the small handle **2** to lock the retainer into position and secure the new microprocessor in the socket.

**Note:** There are two marks on the microprocessor retainer. Ensure that you close the small handle marked with **1** first and then close the small handle marked with **2**. Always follow the correct sequence when you close the small handles.

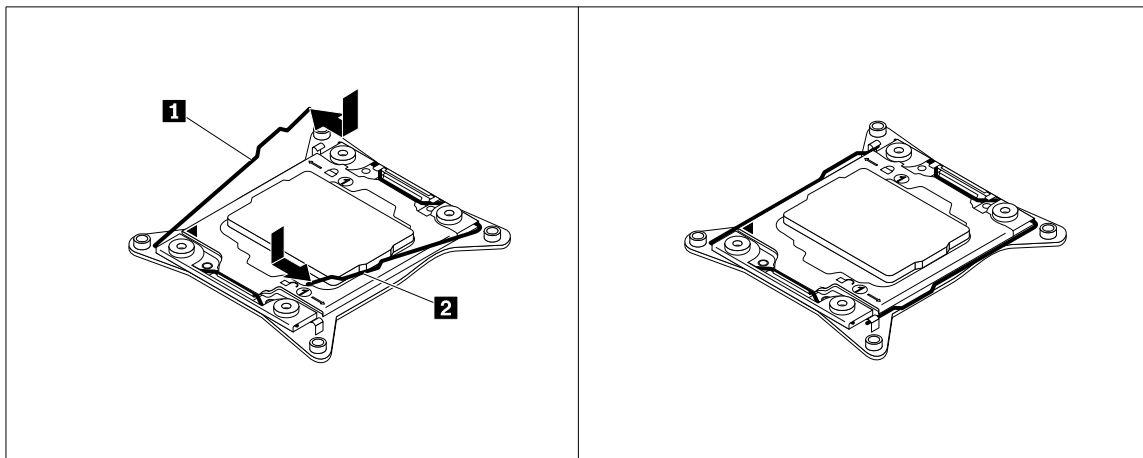

Figure 106. Securing the microprocessor in the socket

13. Use a cleaning pad to wipe the thermal grease from the removed heat sink. Dispose of the cleaning pad after all of the thermal grease is removed.
14. Use one of the following methods to apply appropriate amount of thermal grease to the top of the newly installed microprocessor in the shape of a cross or a circle as shown. Using too much or too less thermal grease can cause a thermal problem due to imperfect contact with the components.

**Notes:**

- Do not touch the thermal grease.
- Keep the thermal grease off the system board.



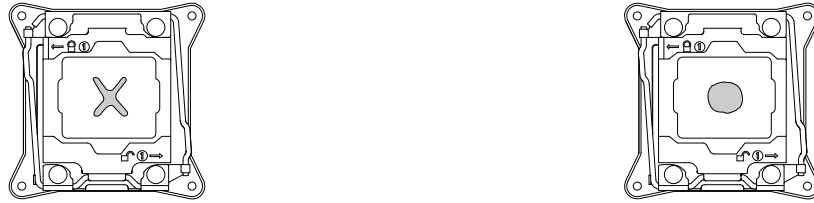

Figure 107. Applying the thermal grease to the top of the microprocessor

15. Reinstall the heat sink. See “Installing or replacing a heat sink” on page 113.
16. If you are instructed to return the old microprocessor, follow all packaging instructions and use any packaging materials that are supplied to you for shipping.

**What to do next:**

- To work with another piece of hardware, go to the appropriate section.
- To complete the replacement, go to “Completing the parts replacement” on page 154.

## Installing or replacing a hot-swap redundant power supply

Depending on the model, your server might come with one or two hot-swap redundant power supplies. When the server is populated with two hot-swap redundant power supplies, the server can withstand a power loss from either power supply. This helps you avoid significant interruption to the operation of the server when a power supply fails. You can replace the failing hot-swap redundant power supply without turning off the server.

Some server models come with only one power supply. You can purchase a hot-swap redundant power supply from the Lenovo Web site at:

<http://lenovoquickpick.com/usa/home/thinkserver/rack-and-tower-server>

**CAUTION:**

**Hazardous moving parts. Keep fingers and other body parts away.**

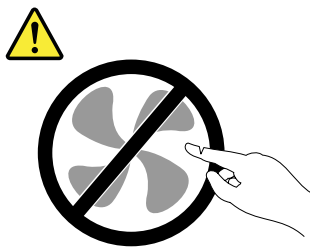

**CAUTION:**

**Never remove the cover on a power supply or any part that has the following label attached.**



**Hazardous voltage, current, and energy levels are present inside any component that has this label attached. There are no serviceable parts inside these components. If you suspect a problem with one of these parts, contact a service technician.**

**Notes:**

- To maintain the EMI integrity and cooling of the server, install a new power supply as soon as you remove the failing one. Cover the other bay with a shield if you just use one power supply to provide power.
- Use any documentation that comes with the new power supply and follow those instructions in addition to the instructions in this topic.

### Installing a hot-swap redundant power supply

**Attention:** Do not open your server or attempt any repair before reading and understanding “Read this first: safety information” on page v and “Guidelines” on page 59.

Before you begin, print all the related instructions or ensure that you can view the PDF version on another computer for reference.

To install a hot-swap redundant power supply, do the following:

1. Touch the static-protective package that contains the new hot-swap redundant power supply to any unpainted surface on the outside of the server. Then, take the new hot-swap redundant power supply out of the package.
2. If you are installing a power supply, locate the bay for the power supply in the rear of your server. Insert your index finger and thumb into the holes in the metal shield that protects the bay and pull the shield out of the chassis. Store the shield in case that you later remove the power supply and need the shield to cover the bay.

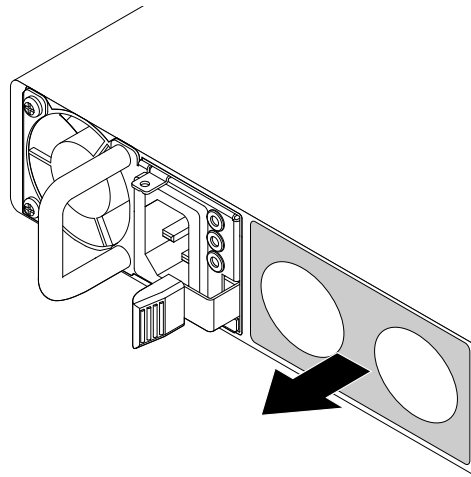

*Figure 108. Removing the protective shield for the power supply bay*

3. Note the orientation of the new hot-swap redundant power supply and then slide the new hot-swap redundant power supply into the chassis until it snaps into position.

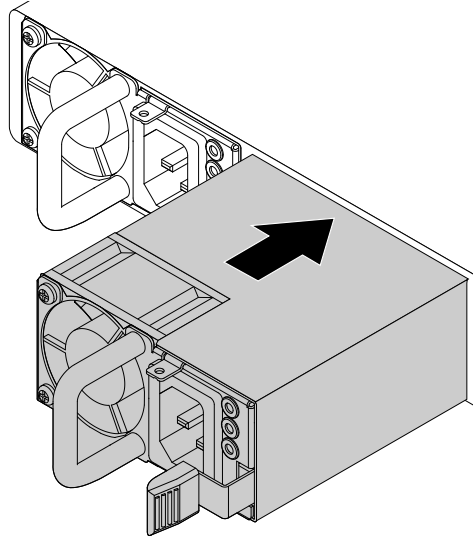

Figure 109. Installing a hot-swap redundant power supply

4. Connect the power cord to the power connector on the new hot-swap redundant power supply. Then, check the status LED near the power connector. When the LED is lit in green, it indicates that the hot-swap redundant power supply is working correctly. When the LED is lit in amber, it indicates that the hot-swap redundant power supply is likely to fail or has failed. You need to reinstall or replace it.

## Replacing a hot-swap redundant power supply

**Attention:** Do not open your server or attempt any repair before reading and understanding “Read this first: safety information” on page v and “Guidelines” on page 59.

Before you begin, print all the related instructions or ensure that you can view the PDF version on another computer for reference.

**Note:** Use any documentation that comes with the hot-swap redundant power supply and follow those instructions in addition to the instructions in this topic.

To replace a hot-swap redundant power supply, do the following:

1. Locate the failing hot-swap redundant power supply in the rear of your server. Then, disconnect the power cord from the failing hot-swap redundant power supply.
2. Press the tab **1** inward and carefully pull the handle **2** to slide the hot-swap redundant power supply out of the chassis.

**Note:** Do not use too much force. You can first carefully slide the hot-swap redundant power supply a little bit out to release it from the secured position. Then, completely slide it out of the chassis.

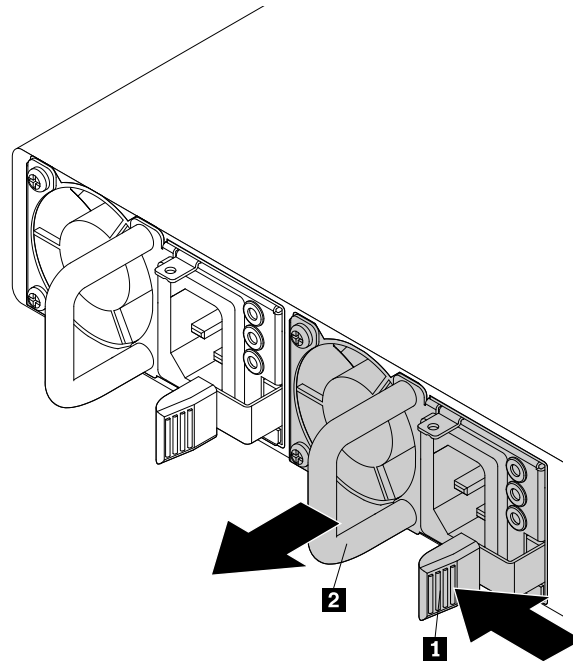

Figure 110. Removing a hot-swap redundant power supply

3. Install a new hot-swap redundant power supply. See “Installing a hot-swap redundant power supply” on page 124.
4. If you are instructed to return the old hot-swap redundant power supply, follow all packaging instructions and use any packaging materials that are supplied to you for shipping.

## Installing or replacing a hot-swap hard disk drive

**Attention:** Do not open your server or attempt any repair before reading and understanding “Read this first: safety information” on page v and “Guidelines” on page 59.

You can install or replace a hot-swap hard disk drive without turning off the server, which helps you avoid significant interruption to the operation of the system.

For a list of the ThinkServer hard disk drive options, go to:

<http://lenovoquickpick.com/usa/home/thinkserver/rack-and-tower-server>

The EMI integrity and cooling of the server are protected by having all drive bays covered or occupied. The number of the installed hard disk drives in your server varies depending on the server model. The vacant bays are occupied by dummy hard-disk-drive trays. When you install a hot-swap hard disk drive, save the removed dummy hard-disk-drive tray from the drive bay in case that you later remove the hot-swap hard disk drive and need the dummy tray to cover the place.

**Attention:** An unoccupied drive bay without any other protection might impact the EMI integrity and cooling of the server, which might result in overheating or component damage. To maintain the EMI integrity and cooling of the server, install a new hot-swap hard disk drive as soon as you remove the failing one or the dummy tray.

Before you begin, review the following hard disk drive installation rules:

- Follow the order of the hard-disk-drive bays when installing a hard disk drive. See “Front view of the server” on page 17 to locate the hard-disk-drive bays in your server.
- For RAID configuration, the hard disk drives must be the same type with the same capacity if they are within a single RAID array. For more information, see “Configuring RAID” on page 54.

Before you begin, print all the related instructions or ensure that you can view the PDF version on another computer for reference.

**Notes:**

- Depending on the model, your server might come with 3.5-inch hot-swap hard disk drives or 2.5-inch hot-swap hard disk drives. The illustrations in this topic are based on server models with 3.5-inch hot-swap hard disk drives. For other models, the replacement procedure is similar.
- Use any documentation that comes with the hot-swap hard disk drive and follow those instructions in addition to the instructions in this topic.

To install or replace a hot-swap hard disk drive, do the following:

1. Locate the appropriate hard-disk-drive bay. See “Front view of the server” on page 17.
2. Press the release button **1** to open the handle of the hot-swap hard disk drive or the dummy tray.

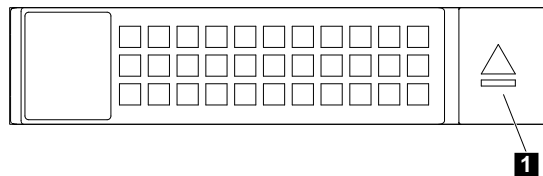

Figure 111. Opening the handle of a hard disk drive

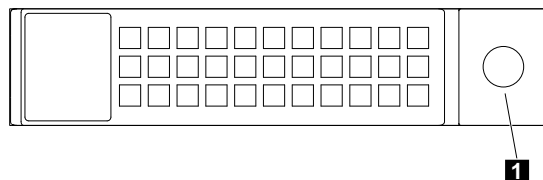

Figure 112. Opening the handle of a dummy hard-disk-drive tray

3. Pull the handle and carefully slide the hot-swap hard disk drive or the dummy tray out of the front of the chassis.

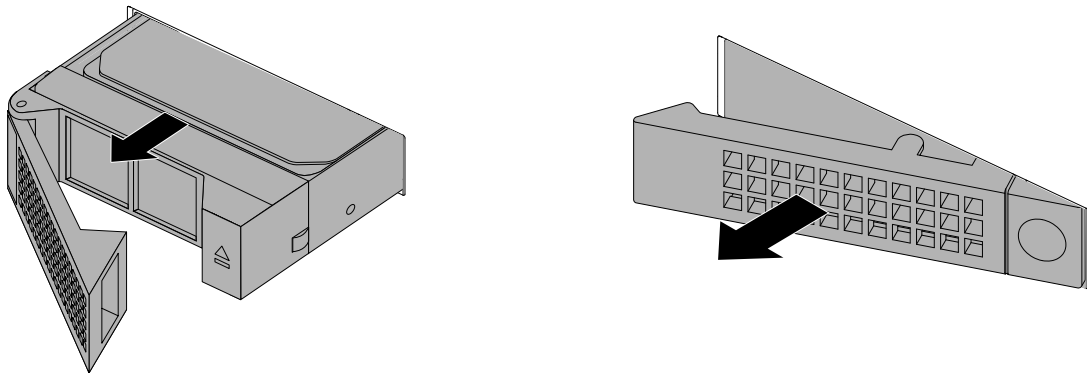

Figure 113. Removing the hot-swap hard disk drive or the dummy tray

4. Touch the static-protective package that contains the new hot-swap hard disk drive to any unpainted surface on the outside of the server. Then, take the new hot-swap hard disk drive out of the package.

**Note:** Do not touch the circuit board on the hard disk drive.

5. Slide the new hot-swap hard disk drive into the drive bay from the front until it snaps into position and then completely close the handle.

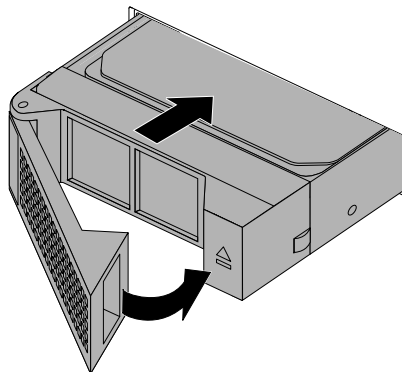

Figure 114. Installing the hot-swap hard disk drive

6. Check the hot-swap hard-disk-drive status LEDs to ensure that the hard disk drive is operating correctly. You might have to restart the server for the newly installed hard disk drive to be recognized. See “Hot-swap-drive status LEDs” on page 41. If the hard disk drive is faulty, you need to reinstall or replace it until it is operating correctly.
7. Do one of the following:
  - If you are installing a hot-swap hard disk drive, save the removed dummy hard-disk-drive tray in case that you later remove the hot-swap hard disk drive and need a dummy tray to cover the drive bay.

- If you are replacing a hot-swap hard disk drive and are instructed to return the old hot-swap hard disk drive, follow all packaging instructions and use any packaging materials that are supplied to you for shipping.

**What to do next:**

- To work with another piece of hardware, go to the appropriate section.
- To configure RAID, go to “Configuring RAID” on page 54.

## Installing or replacing an easy-swap drive

**Attention:** Do not open your server or attempt any repair before reading and understanding “Read this first: safety information” on page v and “Guidelines” on page 59.

This topic applies only to server models that have easy-swap drives installed. See “Features” on page 7 for information about the supported easy-swap drives.

For a list of ThinkServer options, go to:

<http://lenovoquickpick.com/usa/home/thinkserver/rack-and-tower-server>

The EMI integrity and cooling of the server are protected by having all drive bays covered or occupied. The number of the installed drives in your server varies depending on the server model. The vacant bays are either covered by an EMI-protective panel or occupied by dummy trays. When installing a drive, save the removed dummy tray in case that you later remove the drive and need the dummy tray to cover the place.

**Attention:** An unoccupied drive bay without any other protection might impact the EMI integrity and cooling of the server, which might result in overheating or component damage. To maintain the EMI integrity and cooling of the server, install a new drive as soon as you remove the failing one or the dummy tray.

Before you begin, print all the related instructions or ensure that you can view the PDF version on another computer for reference.

**Notes:**

- You must turn off the server before installing or replacing an easy-swap drive to avoid data lost.
- Use any documentation that comes with the drive and follow those instructions in addition to the instructions in this topic.

To install or replace an easy-swap drive, do the following:

1. Review the following installation rules:
  - When you install drives, follow the order of the drive bay numbers. See “Front view of the server” on page 17 to locate the drive bays in your server.
  - For RAID configuration, the drives must be the same type with the same capacity if they are within a single RAID array. For more information, see “Configuring RAID” on page 54.
2. Remove all external media from the drives and turn off all attached devices and the server. Then, disconnect all power cords from electrical outlets and disconnect all cables that are connected to the server.
3. Prepare your server. See “Removing or extending the server from the rack cabinet” on page 61.
4. Locate the appropriate easy-swap-drive bay. See “Front view of server models with 2.5-inch drives” on page 18.
5. Use a screwdriver to turn the handle lock **1** to the unlocked position. The handle opens automatically.

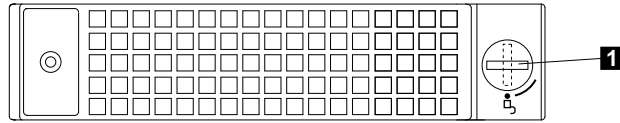

Figure 115. Opening the handle of the easy-swap drive or the dummy tray

6. Pull the handle and carefully slide the easy-swap drive or the dummy tray out of the front of the chassis.

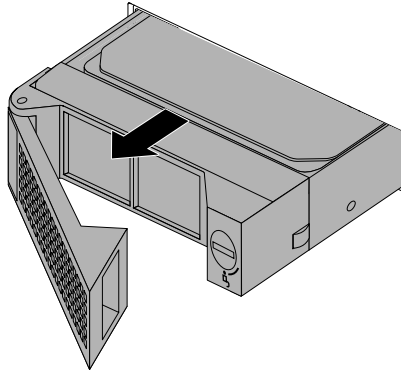

Figure 116. Removing the easy-swap drive or the dummy tray

7. Do one of the following:
  - If you are replacing an easy-swap drive, remove the four screws to remove the failing drive from the drive tray.

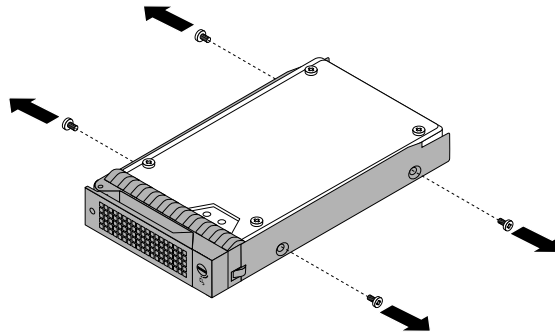

Figure 117. Removing the drive from the drive tray

- If you are installing an easy-swap drive, go to the next step.
8. Touch the static-protective package that contains the new easy-swap drive to any unpainted surface on the outside of the server. Then, take the new easy-swap drive out of the package.
  9. Align the holes in the drive tray with the corresponding ones on the new easy-swap drive. Then, install the four screws to secure the drive to the drive tray.



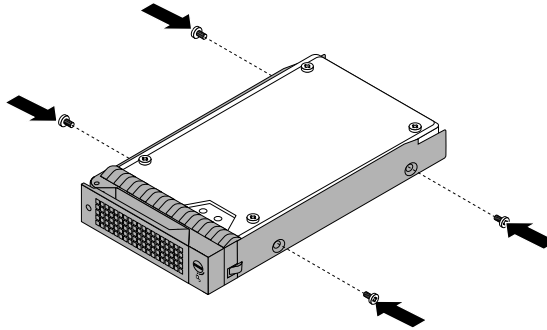

Figure 118. Installing the drive to the drive tray

10. Slide the new easy-swap drive into the drive bay from the front until it snaps into position, and then close the handle.

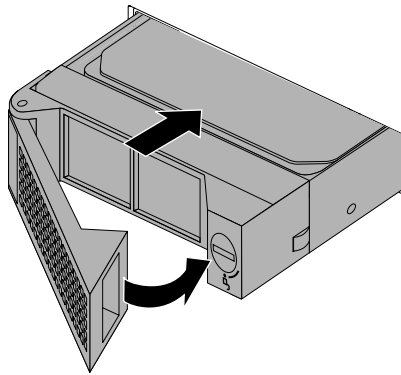

Figure 119. Installing the easy-swap drive

11. Do one of the following:
  - If you are installing a drive, save the removed dummy tray in case that you later remove the drive and need a dummy tray to cover the drive bay.
  - If you are replacing a drive and are instructed to return the old drive, follow all packaging instructions and use any packaging materials that are supplied to you for shipping.

**What to do next:**

- To work with another piece of hardware, go to the appropriate section.
- To configure RAID, go to “Configuring RAID” on page 54.

## Installing or replacing a 2.5-inch drive

You can install or replace a hot-swap 2.5-inch drive without turning off the server, which helps you avoid significant interruption to the operation of the system.

For a list of ThinkServer drive options, go to:

<http://lenovoquickpick.com/usa/home/thinkserver/rack-and-tower-server>

The EMI integrity and cooling of the server are protected by having all drive bays covered or occupied. The number of the installed drives in your server varies depending on the server model. The vacant bays are occupied by dummy hard-disk-drive trays. When you install a hot-swap drive, save the removed dummy hard-disk-drive tray from the drive bay in case that you later remove the hot-swap drive and need the dummy tray to cover the place.

**Attention:** An unoccupied drive bay without any other protection might impact the EMI integrity and cooling of the server, which might result in overheating or component damage. To maintain the EMI integrity and cooling of the server, install a new hot-swap drive as soon as you remove the failing one or the dummy tray.

Before you begin, review the following drive installation rules:

- Follow the order of the hard-disk-drive bays when installing a 2.5-inch drive. See “Server components” on page 24 to locate the hard-disk-drive bays in your server.
- For RAID configuration, the 2.5-inch drives must be the same type with the same capacity if they are within a single RAID array. For more information, see “Configuring RAID” on page 54.

Before you begin, print all the related instructions or ensure that you can view the PDF version on another computer for reference.

**Notes:**

- Depending on the model, your server might come with 3.5-inch hot-swap hard disk drives or 2.5-inch drives. The illustrations in this topic are based on server models with 3.5-inch hot-swap hard disk drives. For other models, the replacement procedure is similar.
- Depending on the model, your server might look slightly different from the illustrations in this topic.
- Use any documentation that comes with the 2.5-inch drive and follow those instructions in addition to the instructions in this topic.

### Installing a 2.5-inch drive into a 3.5-inch hard-disk-drive bay

**Attention:** Do not open your server or attempt any repair before reading and understanding “Read this first: safety information” on page v and “Guidelines” on page 59.

Before you begin, print all the related instructions or ensure that you can view the PDF version on another computer for reference.

**Note:** Ensure that you have a 3.5-inch to 2.5-inch drive adapter and a 3.5-inch drive bracket available before the installation.

To install a 2.5-inch drive into a 3.5-inch hard-disk-drive bay, do the following:

1. Locate the appropriate hard-disk-drive bay. See “Front view of the server” on page 17.
2. Press the release button **1** to open the handle of the dummy hard-disk-drive tray.

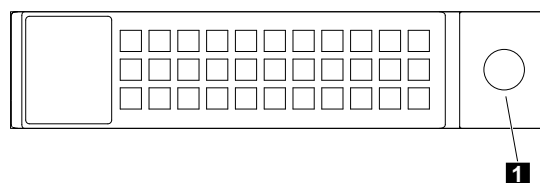

Figure 120. Opening the handle of the dummy hard-disk-drive tray

3. Pull the handle and carefully slide the dummy hard-disk-drive tray out of the front of the chassis.

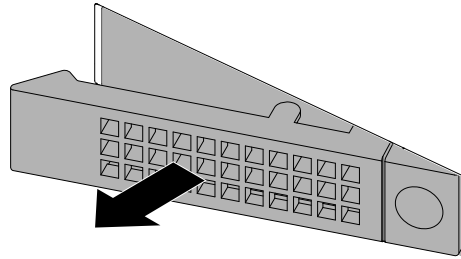

Figure 121. Removing the dummy hard-disk-drive tray

4. Touch the static-protective package that contains the 2.5-inch drive to any unpainted surface on the outside of the server. Then, take the 2.5-inch drive out of the package.

**Note:** Do not touch the circuit board on the 2.5-inch drive.

5. Position the 2.5-inch drive into the 3.5-inch to 2.5-inch drive adapter as shown in the following illustration.

Figure 122. Positioning the 2.5-inch drive into the drive adapter

6. Align the two screw holes in the 2.5-inch drive with the corresponding holes in the drive adapter. Then, install the two screws to secure the 2.5-inch drive to the drive adapter.

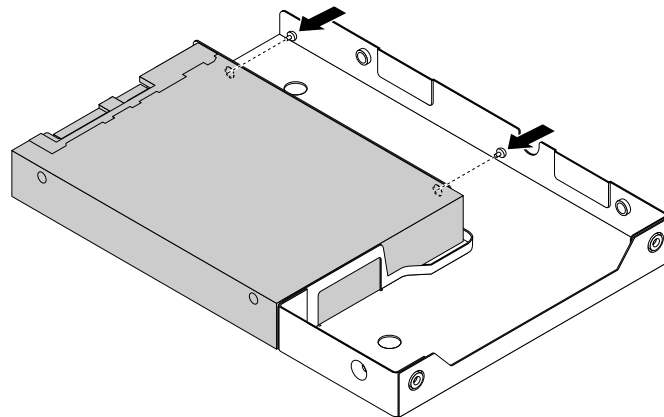

Figure 123. Installing the screws to secure the 2.5-inch drive to the drive adapter

7. Position the drive adapter with the 2.5-inch drive into the 3.5-inch drive bracket.
8. Align the screw holes in the drive adapter and the 2.5-inch drive with the corresponding holes in the drive bracket. Then, install the five screws to secure the drive adapter and the 2.5-inch drive to the bracket.

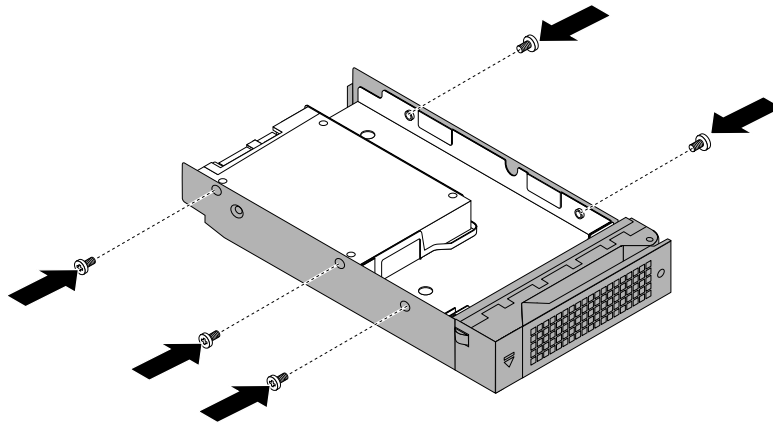

Figure 124. Installing the screws to secure the drive adapter and the 2.5-inch drive to the bracket

9. Slide the bracket with the 2.5-inch drive into the drive bay from the front until it snaps into position and then completely close the handle.

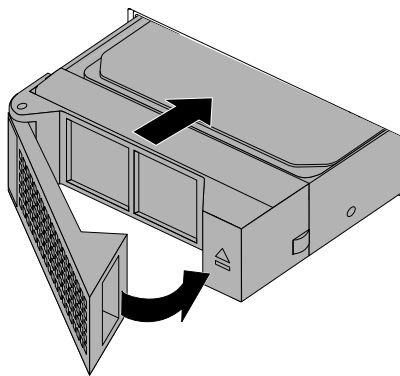

Figure 125. Installing the bracket with the 2.5-inch drive

10. Check the drive status LEDs to ensure that the 2.5-inch drive is operating correctly. You might have to restart the server for the newly installed 2.5-inch drive to be recognized. See “Hot-swap-drive status LEDs” on page 41. If the 2.5-inch drive is faulty, reinstall or replace it until it is operating correctly.
11. Save the removed dummy hard-disk-drive tray in case that you later remove the 2.5-inch drive and need a dummy tray to cover the drive bay.

**What to do next:**

- To work with another piece of hardware, go to the appropriate section.
- To configure RAID, go to “Configuring RAID” on page 54.
- To complete the installation, go to “Completing the parts replacement” on page 154.

**Replacing a 2.5-inch drive from a 3.5-inch hard-disk-drive bay**

**Attention:** Do not open your server or attempt any repair before reading and understanding “Read this first: safety information” on page v and “Guidelines” on page 59.

Before you begin, print all the related instructions or ensure that you can view the PDF version on another computer for reference.

To replace a 2.5-inch drive from a 3.5-inch hard-disk-drive bay, do the following:

1. Locate the appropriate hard-disk-drive bay. See “Front view of the server” on page 17.
2. Press the release button **1** to open the handle of the 3.5-inch drive bracket.

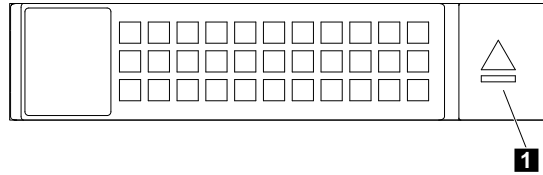

Figure 126. Opening the handle of the 3.5-inch drive bracket

3. Pull the handle and carefully slide the bracket with the 2.5-inch drive out of the front of the chassis.

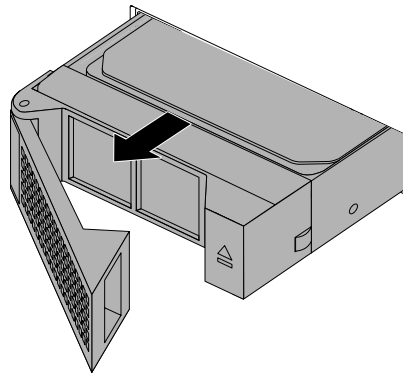

Figure 127. Removing the bracket with the 2.5-inch drive

4. Remove the five screws that secure the 2.5-inch drive and the 3.5-inch to 2.5-inch drive adapter. Then, remove the drive adapter with the 2.5-inch drive from the bracket.

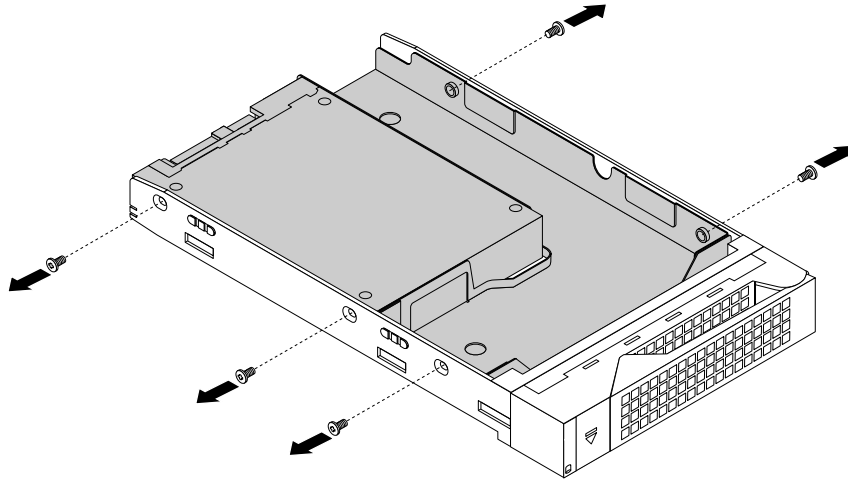

Figure 128. Removing the screws that secure the 2.5-inch drive and the drive adapter

5. Remove the two screws that secure the 2.5-inch drive.

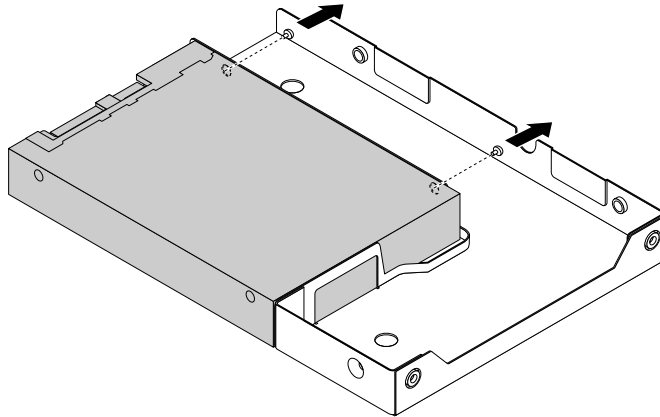

Figure 129. Removing the screws that secure the 2.5-inch drive

6. Lift the 2.5-inch drive up to remove it from the drive adapter.

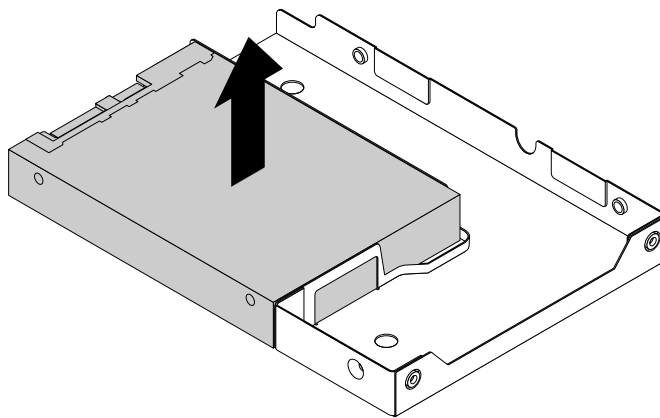

Figure 130. Removing the 2.5-inch drive from the drive adapter

7. Install a new 2.5-inch drive. See “Installing a 2.5-inch drive into a 3.5-inch hard-disk-drive bay” on page 132.
8. If you are instructed to return the old 2.5-inch drive, follow all packaging instructions and use any packaging materials that are supplied to you for shipping.

**What to do next:**

- To work with another piece of hardware, go to the appropriate section.
- To configure RAID, go to “Configuring RAID” on page 54.
- To complete the replacement, go to “Completing the parts replacement” on page 154.

## Installing or replacing the optical drive

**Attention:** Do not open your server or attempt any repair before reading and understanding “Read this first: safety information” on page v and “Guidelines” on page 59.

Before you begin, print all the related instructions or ensure that you can view the PDF version on another computer for reference.

**CAUTION:**

**When laser products (such as CD-ROMs, DVD drives, fiber optic devices, or transmitters) are installed, note the following:**

- **Do not remove the covers. Removing the covers of the laser product could result in exposure to hazardous laser radiation. There are no serviceable parts inside the device.**
- **Use of controls or adjustments or performance of procedures other than those specified herein might result in hazardous radiation exposure.**



**Some laser products contain an embedded Class 3A or Class 3B laser diode. Note the following: Laser radiation when open. Do not stare into the beam, do not view directly with optical instruments, and avoid direct exposure to the beam.**

**Notes:**

- Depending on the model, your server might look slightly different from the illustrations in this topic.
- Use any documentation that comes with the new optical drive and follow those instructions in addition to the instructions in this topic.

To install or replace the optical drive, do the following:

1. Remove all external media from the drives and turn off all attached devices and the server. Then, disconnect all power cords from electrical outlets and disconnect all cables that are connected to the server.
2. Prepare your server. See “Removing or extending the server from the rack cabinet” on page 61.
3. Remove the server cover. See “Removing the server cover” on page 61.
4. Locate the optical drive or dummy optical drive. See “Server components” on page 24.
5. If you are replacing the optical drive, disconnect the signal cable and the power cable from the rear of the optical drive. Press the release button inward and then slide the optical drive out from the front of the server.

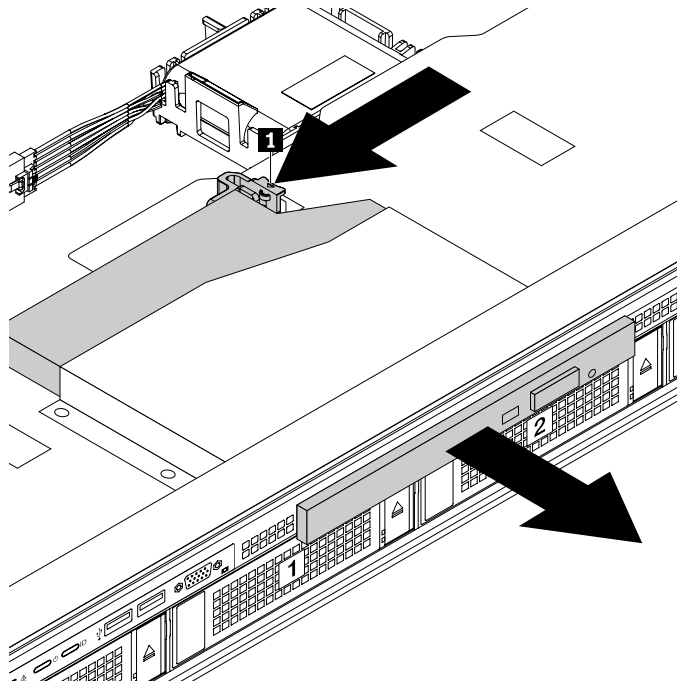

Figure 131. Removing the optical drive

6. Touch the static-protective package that contains the new optical drive to any unpainted surface on the outside of the server. Then, take the new optical drive out of the package.
7. Slide the new optical drive into the drive bay from the front until it is secured by the release button **1**.

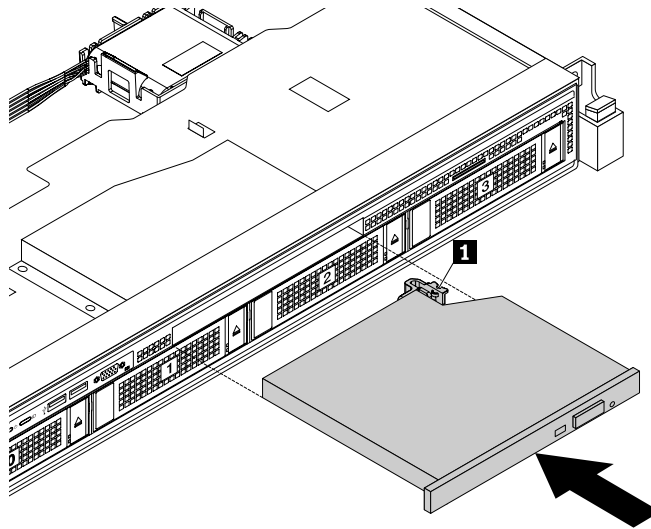

Figure 132. Installing the optical drive

8. Connect the connector **1** to the rear of the optical drive.



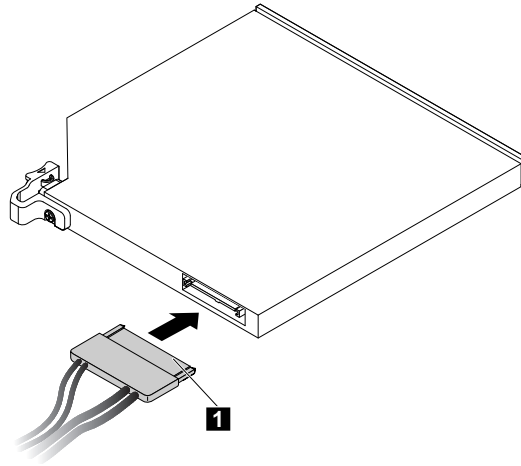

Figure 133. Connecting the connector **1** to the rear of the optical drive

9. If necessary, connect the other end of the signal cable to the SATA connector for the optical drive on the system board. See “System board components” on page 35.
10. If you are instructed to return the old optical drive, follow all packaging instructions and use any packaging materials that are supplied to you for shipping.

**What to do next:**

- To work with another piece of hardware, go to the appropriate section.
- To complete the installation or replacement, go to “Completing the parts replacement” on page 154.

## Connecting an external tape drive

**Attention:** Do not open your server or attempt any repair before reading and understanding “Read this first: safety information” on page v and “Guidelines” on page 59.

Before you begin, print all the related instructions or ensure that you can view the PDF version on another computer for reference.

**Notes:**

- Depending on the model, your tape drive might look slightly different from the illustrations in this topic.
- Use any documentation that comes with the tape drive and follow those instructions in addition to the instructions in this topic.

To connect an external tape drive, do the following:

1. Connect one end of the Y cable to the USB 3.0 connector on the rear of the external tape drive. Then, connect the other end of the Y cable to two available USB connectors on the server.

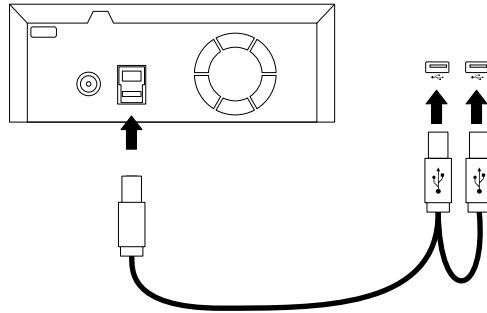

Figure 134. Connecting the external tape drive

2. Verify if the tape drive works correctly.

## Replacing the hot-swap hard-disk-drive backplane

**Attention:** Do not open your server or attempt any repair before reading and understanding “Read this first: safety information” on page v and “Guidelines” on page 59.

Before you begin, print all the related instructions or ensure that you can view the PDF version on another computer for reference.

### Notes:

- The hot-swap hard-disk-drive backplane is sensitive to ESD. Ensure that you read and understand “Handling static-sensitive devices” on page 60 first and carefully perform the operation.
- Depending on the model, your server might look slightly different from the illustrations in this topic.
- The illustrations in the following procedure show the backplane for 3.5-inch hard disk drives. For the backplane for 2.5-inch hard disk drives, the replacement procedure is similar.

To replace the hot-swap hard-disk-drive backplane, do the following:

1. Remove all external media from the drives and turn off all attached devices and the server. Then, disconnect all power cords from electrical outlets and disconnect all cables that are connected to the server.
2. Prepare your server. See “Removing or extending the server from the rack cabinet” on page 61.
3. Remove the server cover. See “Removing the server cover” on page 61.
4. Remove the cooling shroud. See “Removing and reinstalling the cooling shroud” on page 64.
5. Locate the hot-swap hard-disk-drive backplane. See “Server components” on page 24.
6. Remove all the installed hot-swap hard disk drives and dummy trays (if any) from the hard-disk-drive bays. See “Installing or replacing a hot-swap hard disk drive” on page 126.
7. Record the cable connections on the backplane and then disconnect all the cables from the backplane.
8. Press the two latches  in the direction as shown until the latches are disengaged from the chassis. Carefully lift the backplane straight up a little bit so that the small hooks on the chassis are aligned with the corresponding holes in the backplane. Then, move the backplane to the rear of the chassis to release the backplane from the hooks.

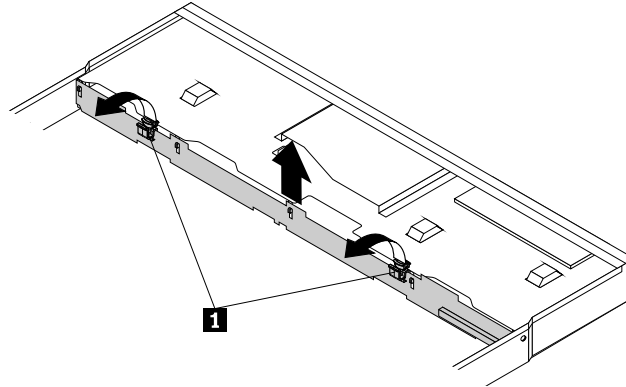

Figure 135. Removing the hot-swap hard-disk-drive backplane

9. Touch the static-protective package that contains the new hot-swap hard-disk-drive backplane to any unpainted surface on the outside of the server. Then, remove the new backplane from the package.

**Note:** Carefully handle the backplane by its edges.

10. Note the orientation of the new backplane. Ensure that the small hooks **1** on the chassis pass through the corresponding holes in the new backplane. Then, carefully press the new backplane straight down so that it is secured by the latches **2** on the backplane.

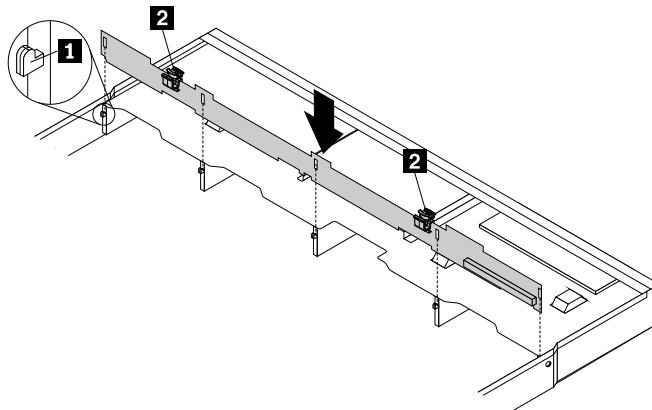

Figure 136. Installing the hot-swap hard-disk-drive backplane

11. Reinstall all the hot-swap hard disk drives and dummy trays (if any) on the backplane. See “Installing or replacing a hot-swap hard disk drive” on page 126.
12. Refer to your note to reconnect the cables to the backplane.
13. If you are instructed to return the old hot-swap hard-disk-drive backplane, follow all packaging instructions and use any packaging materials that are supplied to you for shipping.

**What to do next:**

- To work with another piece of hardware, go to the appropriate section.
- To complete the replacement, go to “Completing the parts replacement” on page 154.

## Replacing a system fan

**Attention:** Do not open your server or attempt any repair before reading and understanding “Read this first: safety information” on page v and “Guidelines” on page 59.

Your server supports up to eight hot-swap system fans. This design helps you to avoid significant cooling problems when a system fan fails and you can replace a hot-swap system fan without turning off the server.

### CAUTION:

**Hazardous moving parts. Keep fingers and other body parts away.**

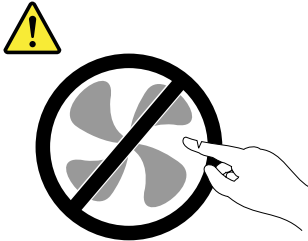

Before you begin, print all the related instructions or ensure that you can view the PDF version on another computer for reference.

**Note:** Depending on the model, your server might look slightly different from the illustrations in this topic.

To replace a system fan, do the following:

1. Prepare your server. See “Removing or extending the server from the rack cabinet” on page 61.
2. Remove the server cover. See “Removing the server cover” on page 61.
3. Remove the cooling shroud. See “Removing and reinstalling the cooling shroud” on page 64.
4. Locate the system fans. View the system fan error LEDs on the system board to locate the failing system fan. See “System board switches” on page 38.
5. Grasp the top of the system fan with your index finger and thumb and then lift the system fan out of the server.

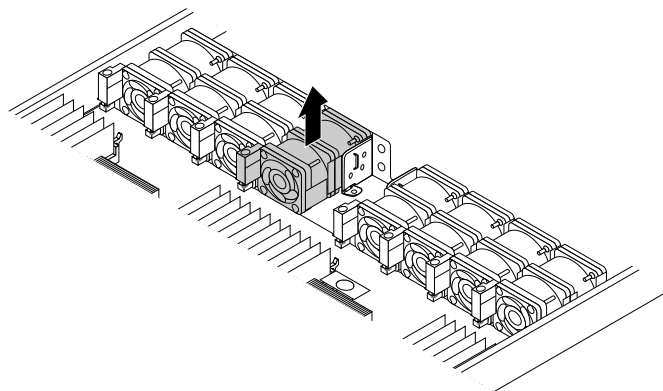

Figure 137. Removing the system fan

6. Touch the static-protective package that contains the new system fan to any unpainted surface on the outside of the server. Then, remove the new system fan from the package.

7. Position the new system fan so that the system fan connector on the bottom of the new system fan is aligned with the system fan connector on the system board. Then, press the new system fan straight down until it is seated into place.

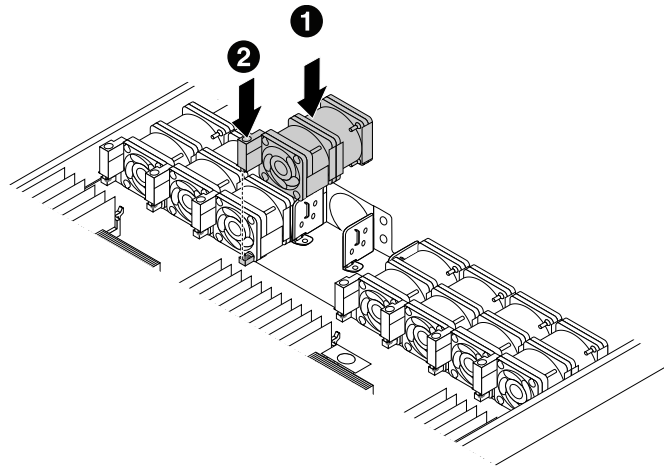

Figure 138. Installing the system fan

8. If you are instructed to return the old system fan, follow all packaging instructions and use any packaging materials that are supplied to you for shipping.

**What to do next:**

- To work with another piece of hardware, go to the appropriate section.
- To complete the replacement, go to “Completing the parts replacement” on page 154.

## Replacing the front panel board

**Attention:** Do not open your server or attempt any repair before reading and understanding “Read this first: safety information” on page v and “Guidelines” on page 59.

Before you begin, print all the related instructions or ensure that you can view the PDF version on another computer for reference.

**Notes:**

- Depending on the model, your server might look slightly different from the illustrations in this topic.
- The illustrations in the following procedure show the front panel board for 3.5-inch hard disk drives. For the front panel board for 2.5-inch hard disk drives, the replacement procedure is similar.
- The front panel board is extremely sensitive to ESD. Ensure that you read and understand “Handling static-sensitive devices” on page 60 first and carefully perform the operation.

To replace the front panel board, do the following:

1. Remove all external media from the drives and turn off all attached devices and the server. Then, disconnect all power cords from electrical outlets and disconnect all cables that are connected to the server.
2. Prepare your server. See “Removing or extending the server from the rack cabinet” on page 61.
3. Remove the server cover. See “Removing the server cover” on page 61.
4. Locate the front panel board.

5. Disconnect the front-panel-board cables from the system board. See “System board components” on page 35.
6. Remove the two screws that secure the front panel board and then carefully remove the front panel board from the chassis.

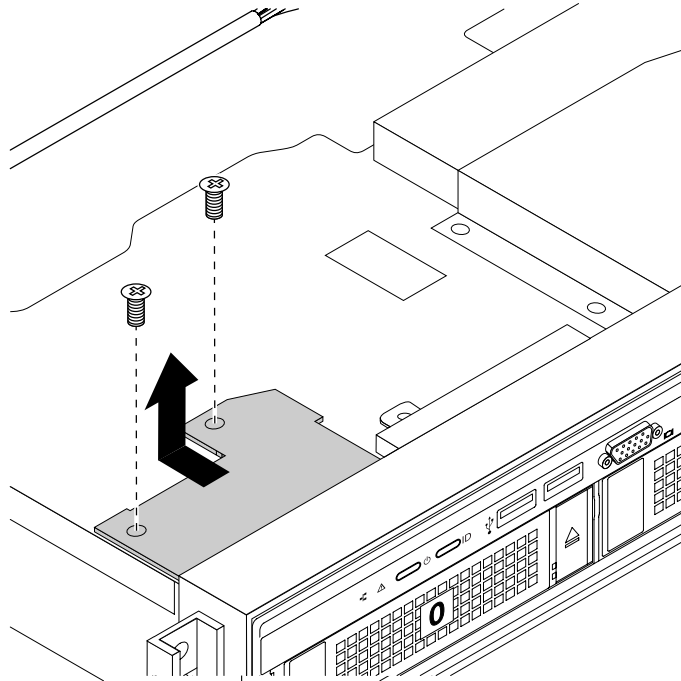

*Figure 139. Removing the front panel board*

7. Touch the static-protective package that contains the new front panel board to any unpainted surface on the outside of the server. Then, take the new front panel board out of the package.

**Note:** Carefully handle the front panel board by its edges.

8. Carefully position the new front panel board so that the two screw holes in the new front panel board are aligned with the corresponding mounting studs on the chassis. Then, install the screws to secure the front panel board in place.

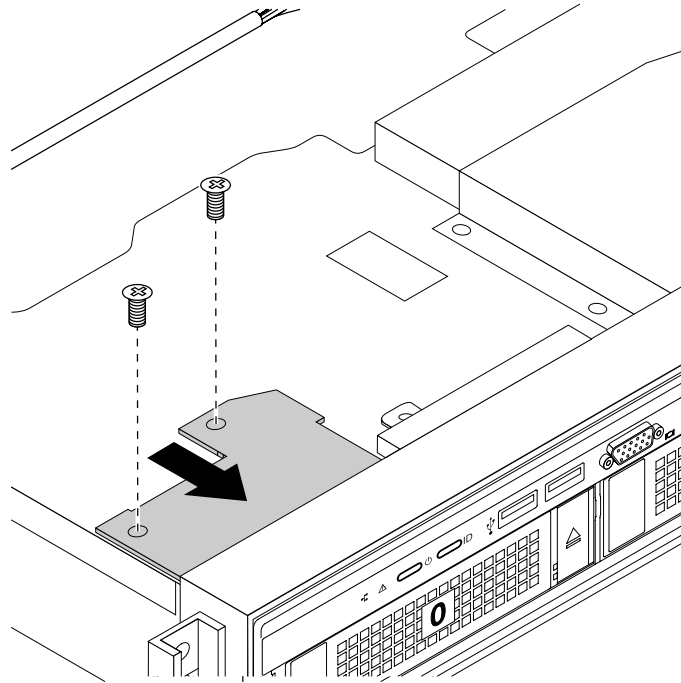

Figure 140. Installing the front panel board

9. Connect the front-panel-board cables to the system board. See “System board components” on page 35.
10. If you are instructed to return the old front panel board, follow all packaging instructions and use any packaging materials that are supplied to you for shipping.

**What to do next:**

- To work with another piece of hardware, go to the appropriate section.
- To complete the replacement, go to “Completing the parts replacement” on page 154.

## Replacing the front VGA and USB module

**Attention:** Do not open your server or attempt any repair before reading and understanding “Read this first: safety information” on page v and “Guidelines” on page 59.

Before you begin, print all the related instructions or ensure that you can view the PDF version on another computer for reference.

To replace the front VGA and USB module, do the following:

1. Remove all external media from the drives and turn off all attached devices and the server. Then, disconnect all power cords from electrical outlets and disconnect all cables that are connected to the server.
2. Prepare your server. See “Removing or extending the server from the rack cabinet” on page 61.
3. Remove the server cover. See “Removing the server cover” on page 61.
4. Locate the front VGA and USB module. See “Server components” on page 24.
5. Disconnect the cable of the front VGA and USB module from the system board.
6. Remove the screw that secures the front VGA and USB module and then remove the module from the chassis as shown.

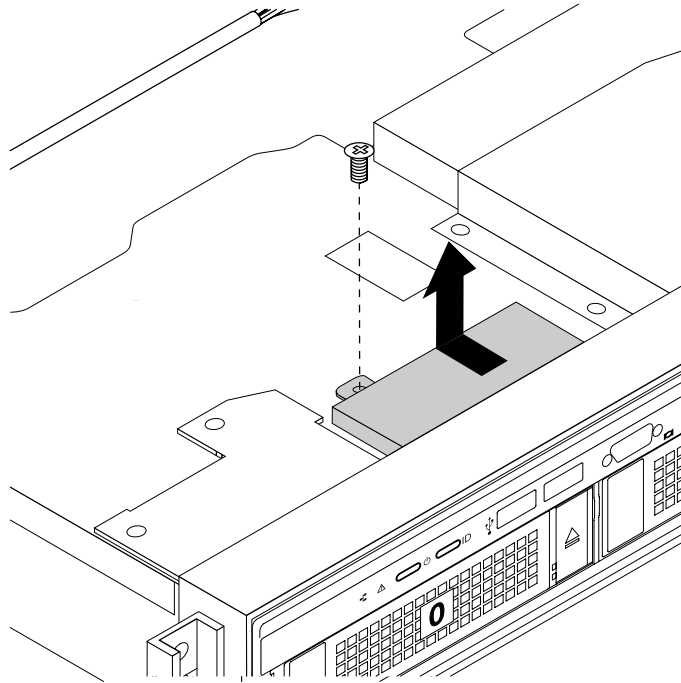

Figure 141. Removing the front VGA and USB module

7. Touch the static-protective package that contains the new front VGA and USB module to any unpainted surface on the outside of the server. Then, take the new module out of the package.
8. Carefully position the new front VGA and USB module on the chassis. Ensure that the VGA and USB connectors are inserted into the corresponding holes in the front bezel. Align the screw hole in the new module with the corresponding mounting stud on the chassis. Then, install the screw to secure the module.

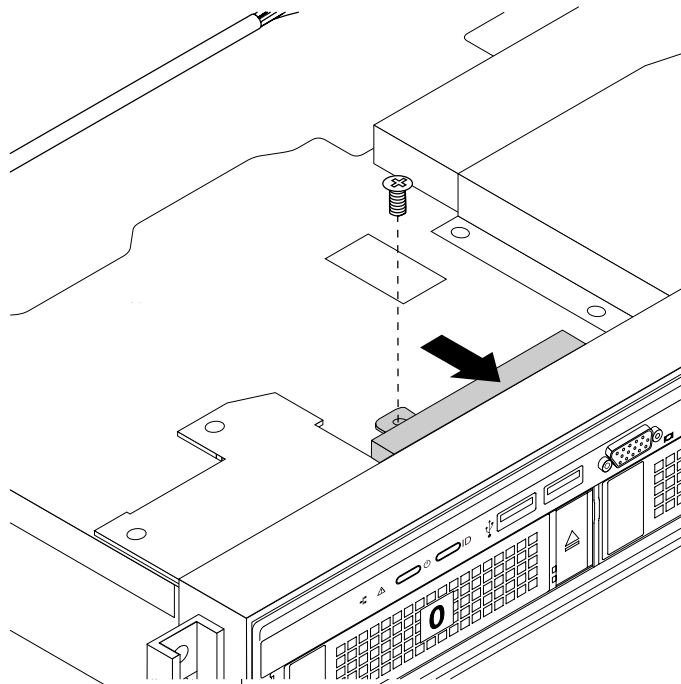

Figure 142. Installing the front VGA and USB module



9. Connect the cable of the front VGA and USB module to the front panel connector 2 on the system board. See “System board components” on page 35.
10. If you are instructed to return the old front VGA and USB module, follow all packaging instructions and use any packaging materials that are supplied to you for shipping.

**What to do next:**

- To work with another piece of hardware, go to the appropriate section.
- To complete the replacement, go to “Completing the parts replacement” on page 154.

## Replacing the riser card assembly

**Attention:** Do not open your server or attempt any repair before reading and understanding “Read this first: safety information” on page v and “Guidelines” on page 59.

Before you begin, print all the related instructions or ensure that you can view the PDF version on another computer for reference.

**Note:** Use any documentation that comes with the new riser card assembly and follow those instructions in addition to the instructions in this topic.

To replace the riser card assembly, do the following:

1. Remove all external media from the drives and turn off all attached devices and the server. Then, disconnect all power cords from electrical outlets and disconnect all cables that are connected to the server.
2. Prepare your server. See “Removing or extending the server from the rack cabinet” on page 61.
3. Remove the server cover. See “Removing the server cover” on page 61.
4. Locate the riser card assembly that you want to remove. See “Server components” on page 24.
5. Grasp the riser card assembly that you want to replace by its edges and carefully lift it straight up and off the chassis.

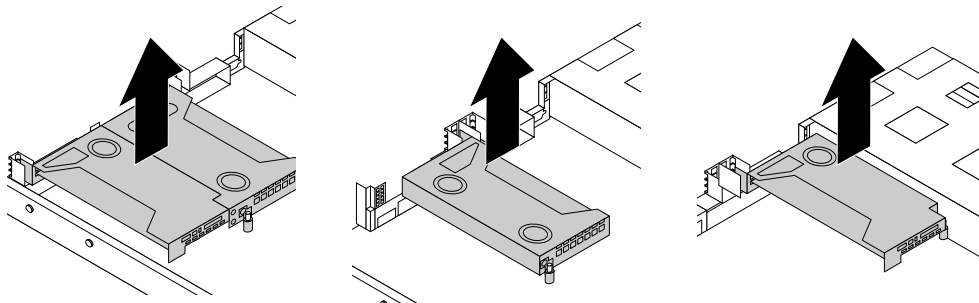

Figure 143. Removing the riser card assembly

6. If there is any PCIe card (such as an Ethernet card) installed on the riser card assembly, record the cable connections, and then disconnect all cables from the card to completely remove the riser card assembly out of the chassis. Then, remove the PCIe card from the riser card assembly. See “Removing a PCIe card” on page 96.
7. Remove the two screws that secure the failing riser card. Then, remove the failing riser card from the bracket.

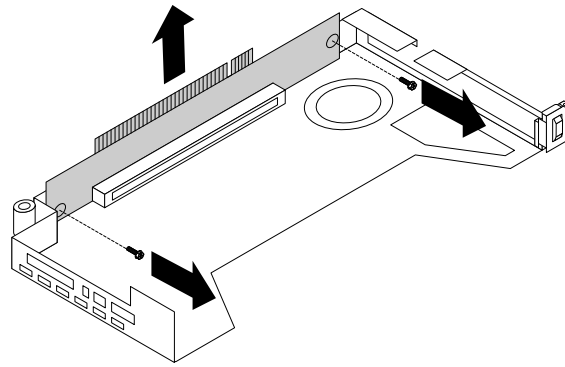

Figure 144. Removing the riser card

8. Touch the static-protective package that contains the new riser card to any unpainted surface on the outside of the server. Then, remove the new riser card from the package.
9. Align the screw holes in the new riser card with the corresponding ones in the bracket. Then, install the two screws to secure the riser card to the bracket.

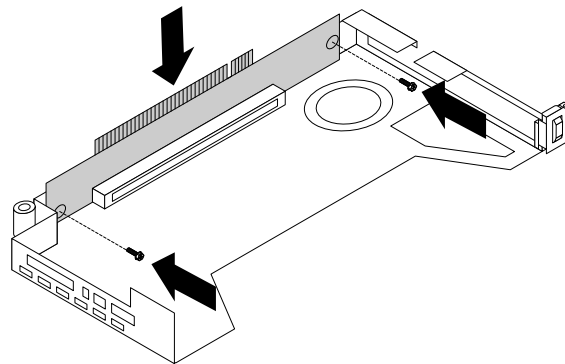

Figure 145. Installing the riser card

10. Reinstall the PCIe card on the new riser card assembly.
11. Position the new riser card assembly on the chassis and align it with the riser card slot on the system board. Align the mounting studs on the system board with the corresponding holes in the riser card assembly. Then, carefully press the riser card assembly straight down into the chassis until it is fully seated.

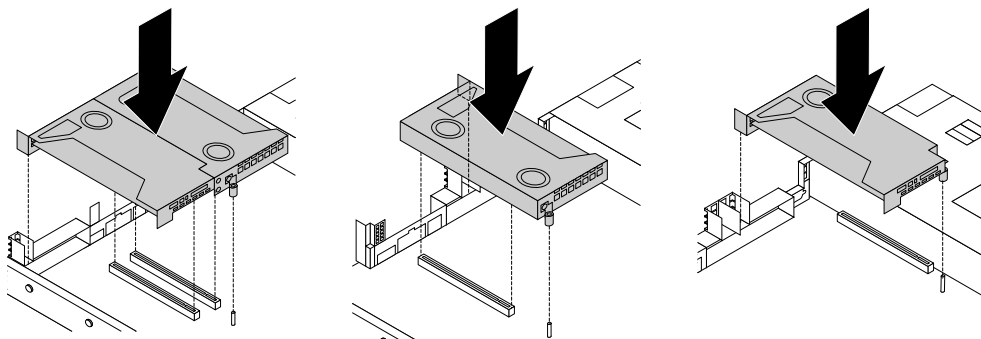

Figure 146. Installing the riser card assembly

12. Reinstall any parts or reconnect any cables that you have removed.

13. If you are instructed to return the old riser card assembly, follow all packaging instructions and use any packaging materials that are supplied to you for shipping.

**What to do next:**

- To work with another piece of hardware, go to the appropriate section.
- To complete the replacement, go to “Completing the parts replacement” on page 154.

## Replacing the coin-cell battery

**Attention:** Do not open your server or attempt any repair before reading and understanding “Read this first: safety information” on page v and “Guidelines” on page 59.

Your server has a special type of memory that maintains the date, time, and configuration information for built-in features. The coin-cell battery keeps the information active when you turn off the server. The coin-cell battery normally requires no charging or maintenance throughout its life; however, no battery lasts forever. If the coin-cell battery fails, the date, time, and configuration information, including passwords, are lost and an error message is displayed when you turn on the server.



**Danger of explosion if battery is incorrectly replaced.**

**When replacing the lithium coin cell battery, use only the same or an equivalent type that is recommended by the manufacturer. The battery contains lithium and can explode if not properly used, handled, or disposed of.**

**Do not:**

- **Throw or immerse into water**
- **Heat to more than 100°C (212°F)**
- **Repair or disassemble**

**Dispose of the battery as required by local ordinances or regulations.**

**The following statement applies to users in the state of California, U.S.A.**

**California Perchlorate Information:**

**Products containing manganese dioxide lithium coin cell batteries may contain perchlorate.**

**Perchlorate Material - special handling may apply, See <http://www.dtsc.ca.gov/hazardouswaste/perchlorate>**

Before you begin, print all the related instructions or ensure that you can view the PDF version on another computer for reference.

To replace the coin-cell battery, do the following:

**Note:** After you replace the coin-cell battery, you must reset passwords, reset system date and time, and reconfigure the server.

1. Remove all external media from the drives and turn off all attached devices and the server. Then, disconnect all power cords from electrical outlets and disconnect all cables that are connected to the server.
2. Prepare your server. See “Removing or extending the server from the rack cabinet” on page 61.
3. Remove the server cover. See “Removing the server cover” on page 61.
4. Locate the coin-cell battery. See “System board components” on page 35.

**Note:** If there is any PCIe card installed on the riser card assembly, it might block your access to the coin-cell battery. In this case, you need to carefully lift the riser card assembly up so that you can access the coin-cell battery. You do not need to disconnect any cables from the riser card assembly or completely remove the riser card assembly.

5. Remove the old coin-cell battery.

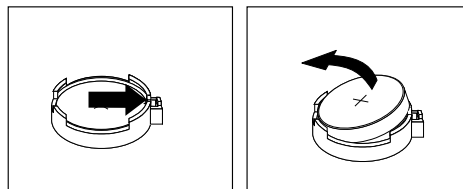

Figure 147. Removing the coin-cell battery

6. Install a new coin-cell battery.

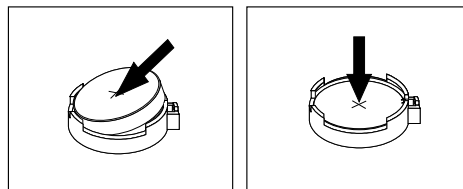

Figure 148. Installing the coin-cell battery

7. If you have lifted up the riser card assembly, reinstall it into the chassis. See “Replacing the riser card assembly” on page 147.
8. Dispose of the old coin-cell battery as required by local ordinances or regulations.

#### What to do next:

- To work with another piece of hardware, go to the appropriate section.
- To complete the replacement, go to “Completing the parts replacement” on page 154.

**Note:** After you replace the system board battery, you must reset passwords, reset system date and time, and reconfigure the server. See Chapter 5 “Configuring the server” on page 47.

## For service technician only: replacing the system board

**Attention:** This procedure must be performed only by trained service personnel of Lenovo. Do not open your server or attempt any repair before reading and understanding “Read this first: safety information” on page v and “Guidelines” on page 59.

#### CAUTION:

**Hazardous moving parts. Keep fingers and other body parts away.**

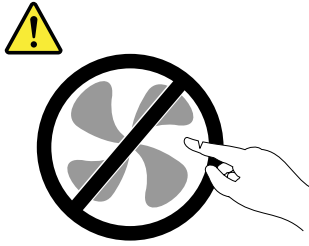

**CAUTION:**



**The heat sinks and microprocessors might be very hot. Turn off the server and wait several minutes to let the server cool before removing the server cover.**

Before you begin, print all the related instructions or ensure that you can view the PDF version on another computer for reference.

**Note:** Depending on the model, your server might look slightly different from the illustrations in this topic.

To replace the system board, do the following:

1. Remove all external media from the drives and turn off all attached devices and the server. Then, disconnect all power cords from electrical outlets and disconnect all cables that are connected to the server.
2. Prepare your server. See “Removing or extending the server from the rack cabinet” on page 61.
3. Remove the server cover. See “Removing the server cover” on page 61.
4. Remove the cooling shroud. See “Removing the cooling shroud” on page 64.
5. Remove the system fans. See “Replacing a system fan” on page 142.
6. Record the component locations, cable connections, and cable routing in the server.
7. Remove the two riser card assemblies. See “Replacing the riser card assembly” on page 147.
8. Remove the rear backplane/cage kit. See “Removing the rear backplane/cage kit” on page 105.
9. Remove the AnyFabric adapter if one is installed. See “Removing the AnyFabric adapter” on page 90.
10. Remove all memory modules. See “Removing a memory module” on page 70.
11. Remove the TSM Premium module if one is installed. See “Removing the TSM Premium module” on page 72.
12. Remove the TPM if one is installed. See “Installing or removing the ThinkServer Trusted Platform Module” on page 73.
13. Remove the SD module if one is installed. See “Removing the SD module” on page 83.
14. Remove the M.2 storage module if one is installed. See “Removing the M.2 storage module” on page 86.
15. Remove the coin-cell battery. See “Replacing the coin-cell battery” on page 149.
16. Remove the heat sinks. See “Installing or replacing a heat sink” on page 113.
17. Disconnect all cables from the system board.
18. Lift the release pin **1** and the lifting handle **2** to disengage the system board from the chassis. Then, move the system board to the front of the server and carefully pivot the system board upward to remove it out of the chassis.

**Note:** Carefully handle the system board by the release pin **1** and the lifting handle **2**.

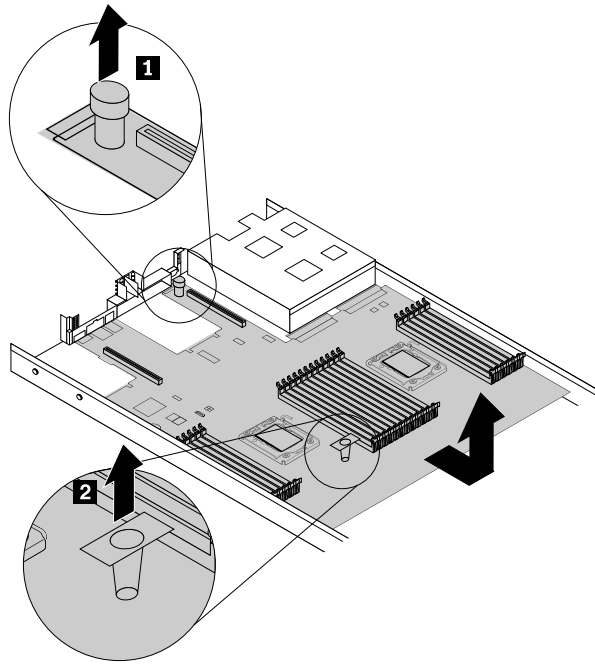

Figure 149. Removing the system board

19. Place the old system board on a clean, flat, and static-protective surface. Touch the static-protective package that contains the new system board to any unpainted surface on the outside of the server. Then, take the new system board out of the package.
20. Install the new system board into the chassis and press the system board to the rear of the server. Ensure that:
  - The new system board is engaged by the mounting stud on the chassis.
  - The rear connectors on the new system board are inserted into the corresponding holes in the rear panel.

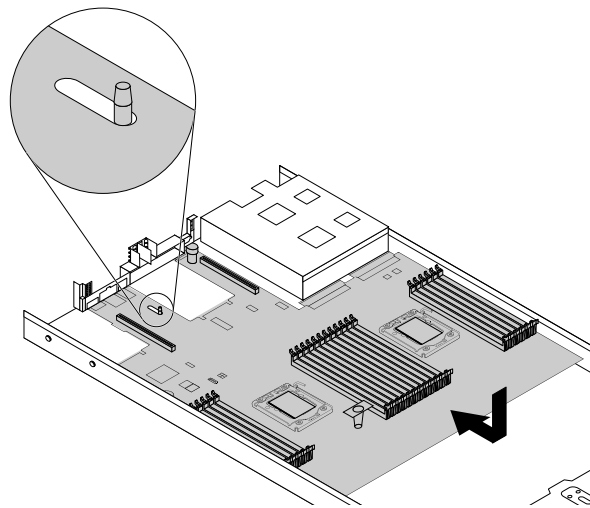

Figure 150. Installing the system board

21. Remove the microprocessors from the old system board and install them on the new system board. See “Installing or replacing the microprocessor” on page 115.

**Note:** Do not drop anything onto the microprocessor socket on the old system board while it is exposed. The socket pins must be kept as clean as possible.

22. Use a cleaning pad to wipe the thermal grease from the heat sinks and the top of the microprocessors. Dispose of the cleaning pad after all of the thermal grease is removed.
23. Use one of the following methods to apply appropriate amount of thermal grease to the top of the microprocessors in the shape of a cross or a circle as shown. Using too much or too less thermal grease can cause a thermal problem due to imperfect contact with the components.

**Notes:**

- Do not touch the thermal grease.
- Keep the thermal grease off the system board.



Figure 151. Applying the thermal grease to the top of the microprocessor

24. Install the heat sinks on the new system board. See “Installing or replacing a heat sink” on page 113.
25. Reinstall all parts that you have removed one by one in the reversed sequence as you remove them. Connect all cables to the new system board. Refer to the information that you have noted down and the related topics in “Installing, removing, or replacing hardware” on page 62.
26. If you are instructed to return the old system board, follow all packaging instructions and use any packaging materials that are supplied to you for shipping.

The old system board must be returned with two microprocessor socket covers to protect the pins on the microprocessor sockets during shipping and handling. Use the microprocessor socket covers removed from the new system board.

To install a microprocessor socket cover on the old system board, do the following:

1. Close the microprocessor retainer. Close the small handle **1** first and then close the small handle **2**. Ensure that the retainer is locked into position and the new microprocessor is securely seated in the socket.

**Note:** There are two marks on the microprocessor retainer. Ensure that you close the small handle marked with **1** first and then close the small handle marked with **2**. Always follow the correct sequence when you close the small handles.

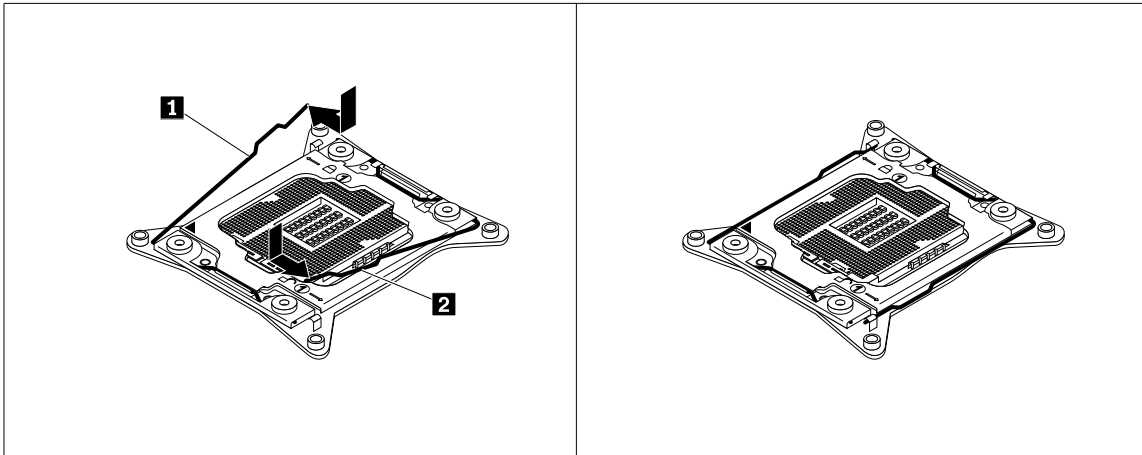

Figure 152. Securing the microprocessor retainer

- Position the microprocessor socket cover above the microprocessor socket so that the small triangle **1** on the socket cover faces the small triangle **2** on the microprocessor retainer. Then, carefully press the socket cover straight down into the socket until it snaps into position.

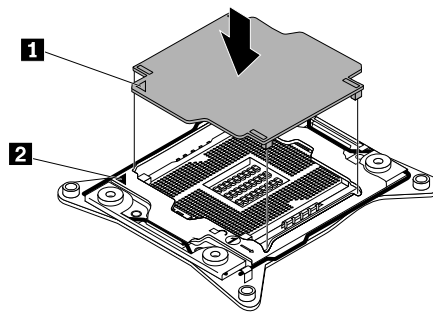

Figure 153. Installing the microprocessor socket cover

#### What to do next:

- To work with another piece of hardware, go to the appropriate section.
- To complete the replacement, go to “Completing the parts replacement” on page 154.
- After a system board is replaced, do the following:
  - Start the Setup Utility program by pressing the F1 key, and then check the BIOS and BMC version.
  - Go to <http://www.lenovo.com/drivers> and follow the instructions on the Web page to download the latest version of firmware. Then, install the firmware to your server.
  - Update the machine type, model number, and serial number of the system board. Either you will be prompted to do this while upgrading the BIOS, or you can locate the files for updating the VPD within the DOS BIOS package. For some servers, the VPD utility is available for download at: <http://www.lenovo.com/drivers>.

---

## Completing the parts replacement

This topic provides instructions to help you complete the parts replacement and turn on your server.



To complete the parts replacement, you must properly route the cables inside the server, reinstall the server cover, reconnect all the external cables and, for some devices, update the firmware and run the Setup Utility program to do further setup.

## Reinstalling the server cover and reconnecting cables

**Attention:** Do not open your server or attempt any repair before reading and understanding “Read this first: safety information” on page v and “Guidelines” on page 59.

This topic provides instructions on how to reinstall the server cover and reconnect cables to your server.

**Attention:** For proper cooling and airflow, reinstall the server cover before turning on the server. Operating the server for extended periods of time (more than 30 minutes) with the server cover removed might damage server components.

Before you begin, print all the related instructions or ensure that you can view the PDF version on another computer for reference.

**Note:** Depending on the model, your server might look slightly different from the illustrations in this topic.

To reinstall the server cover and reconnect cables to your server, do the following:

1. Ensure that all components have been reassembled correctly and that no tools or loose screws are left inside your server.
2. Ensure that all internal cables are routed correctly and secured by any cable clips or ties in the server. Keep cables clear of the hinges and sides of the server chassis to avoid interference with reinstalling the cooling shroud and the server cover.
3. If you have removed the cooling shroud, reinstall it. See “Removing and reinstalling the cooling shroud” on page 64.
4. Ensure that the cover latch is in the open position. Lower the server cover onto the chassis until both sides of the server cover engage the guides on both sides of the chassis. Then, pivot the cover latch and slide the cover to the front of the chassis at the same time until the server cover snaps into position. Ensure that the cover latch is completely closed. Use a screwdriver to turn the cover lock to the closed position.

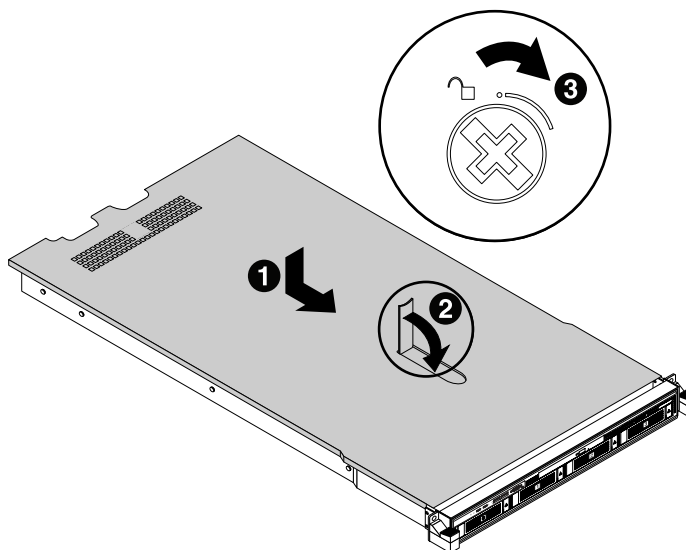

Figure 154. Installing the server cover

5. If the server is installed in a rack cabinet, reinstall the server into the rack cabinet. See the *Rack Installation Instructions* that comes with the server.
6. Reconnect external cables and power cords to the server. See “Rear view of the server” on page 21 to identify the connectors on the rear panel of the server.

**Attention:** To avoid component damage, connect the power cords last.

**Note:** In most areas of the world, Lenovo requires the return of the defective CRU. Information about this will come with the CRU or will come a few days after the CRU arrives.

## Updating the server configuration

When you turn on the server for the first time after you install, remove, or replace a device, you might need to update the server configuration.

Some optional devices have device drivers that you must install. For information about installing device drivers, use the documentation that comes with each optional device. To obtain the supported device drivers for your server from the Lenovo Support Web site, go to <http://www.lenovo.com/drivers> and follow the instructions on the Web page to find and download the device drivers you need.

Refer to the following information resources to update the server configuration:

- To update the BIOS configuration, see “Using the Setup Utility program” on page 47.
- To update the RAID configuration, see “Configuring RAID” on page 54.
- To use the Lenovo ThinkServer Deployment Manager program, see “Lenovo ThinkServer Deployment Manager” on page 13.
- To update your system firmware, see “Updating the firmware” on page 57.

---

## Chapter 7. Troubleshooting and diagnostics

This chapter provides information about basic troubleshooting and diagnostic methods to help you solve problems that might occur in the server.

If you cannot diagnose and correct a problem by using the information in this chapter, see Chapter 8 “Getting information, help, and service” on page 163 for additional troubleshooting resources.

---

### Troubleshooting procedure

Use the following information as a general procedure for diagnosing and troubleshooting problems you experience with your server:

1. Verify that the power cords and the cables for all attached devices are connected correctly and securely.
2. Verify that the server and all attached devices that require ac power are connected to properly grounded, functioning electrical outlets.
3. Verify that all installed hardware and attached devices are enabled in the BIOS settings of your server. For more information about accessing and changing the BIOS settings, see “Using the Setup Utility program” on page 47.
4. View the status and diagnostic LEDs to identify the system and device status and diagnose problems. See “Viewing the status and diagnostic LEDs” on page 157.
5. If the server is not working after you have added new software, installed a new optional device, or replaced a piece of hardware, remove or reinstall the software, device, or hardware to see if the problem could be solved.
6. View the system event log to diagnose problems. See “Viewing the system event log” on page 158.
7. Turn on the server and press Esc as soon as you see the logo screen to view any diagnostic messages.
8. Download and use a diagnostic program to diagnose problems. See “Lenovo ThinkServer Diagnostics” on page 14.
9. Refer to “Basic troubleshooting tables” on page 158 and follow the instructions for the type of problem you are experiencing. If the basic troubleshooting information does not help you resolve a problem, continue with the next step.
10. Try using a previous server configuration to see if a recent change to hardware or software settings has caused a problem. Before restoring your previous configuration, capture your current configuration in case the older configuration settings do not solve the problem or have adverse effect.
11. Use an antivirus program to see if your server has been infected by a virus. If the program detects a virus, remove the virus.
12. If none of these actions solve the problem, seek technical assistance. See Chapter 8 “Getting information, help, and service” on page 163.

---

### Viewing the status and diagnostic LEDs

Your server has status and diagnostic LEDs on the front panel, the rear panel, the system board, the hot-swap storage drives, and the optical drive (if supported). The various LEDs help you easily identify the system and device status and diagnose problems. For information about the LEDs, refer to the related topics in “Locations” on page 16.

---

## Viewing the system event log

The system event log (SEL) contains information about all the POST and system management interrupt (SMI) events. You can view the SEL to diagnose system problems.

The TSM implements the SEL as specified in the IPMI 2.0 specification. The SEL is accessible regardless of the system power state through the TSM in-band and out-of-band interfaces.

For more information about viewing the SEL, refer to the *ThinkServer System Manager User Guide*, which is available for download at <http://www.lenovo.com/UserManuals>.

---

## Basic troubleshooting tables

Use the basic troubleshooting information to find solutions to problems that have definite symptoms.

### Lenovo ThinkServer Deployment Manager program problems

Follow the suggested actions for the corresponding symptom in the order in which they are listed until the problem is solved. If none of these actions solve the problem, see “Troubleshooting procedure” on page 157 for the subsequent steps you should check after using the information in this topic. If the problem still cannot be solved, seek technical assistance. See Chapter 8 “Getting information, help, and service” on page 163.

**Note:** If you are instructed to remove, install, or replace any CRUs, refer to the related procedure in Chapter 6 “Replacing hardware” on page 59.

Symptom	Action
The operating system installation program continuously loops.	Make more space available on the hard disk drive.
The Lenovo ThinkServer Deployment Manager program cannot start the operating system medium.	Ensure that the operating system medium is supported by the Lenovo ThinkServer Deployment Manager program version you are using. For a list of the supported operating systems, refer to the user guide and compatibility notes for the Lenovo ThinkServer Deployment Manager program through the program main interface. See “Lenovo ThinkServer Deployment Manager” on page 13.

### Optical drive problems

Follow the suggested actions for the corresponding symptom in the order in which they are listed until the problem is solved. If none of these actions solve the problem, see “Troubleshooting procedure” on page 157 for the subsequent steps you should check after using the information in this topic. If the problem still cannot be solved, seek technical assistance. See Chapter 8 “Getting information, help, and service” on page 163.

#### Notes:

- If you are instructed to remove, install, or replace any CRUs, refer to the related procedure in Chapter 6 “Replacing hardware” on page 59.
- If an action step is preceded by “(Trained service technician only),” this action step is reserved for a trained service technician and must be performed only by a trained service technician.

Symptom	Action
The optical drive is not recognized.	<ol style="list-style-type: none"> <li>1. Ensure that: <ul style="list-style-type: none"> <li>• The related cables and connectors are not damaged and the connector pins are not bent.</li> <li>• The optical drive is securely connected to the correct SATA connector on the system board and the SATA connector is enabled in the Setup Utility program. See “Using the Setup Utility program” on page 47.</li> <li>• All cables and jumpers (if any) are installed correctly.</li> <li>• The correct device driver is installed for the optical drive.</li> </ul> </li> <li>2. Run any optical drive diagnostic programs if you have.</li> <li>3. Reinstall the optical drive and reconnect cables.</li> <li>4. Replace the signal cable for the optical drive.</li> <li>5. Replace the power cable for the optical drive.</li> <li>6. Replace the power cable for the backplane.</li> <li>7. Replace the optical drive.</li> <li>8. Replace the backplane.</li> <li>9. (Trained service technician only) Replace the system board.</li> </ol>
A disc is not working correctly.	<ol style="list-style-type: none"> <li>1. Ensure that the disc is in the optical drive with the shiny side facing down.</li> <li>2. Ensure that the disc surface is clean and not scratched.</li> <li>3. Check the disc or package for regional coding. You might need to purchase a disc with coding for the region where you are using the product.</li> <li>4. Restart the disc player program.</li> <li>5. Restart the server.</li> <li>6. Run any optical drive diagnostic programs if you have.</li> <li>7. Reinstall the optical drive and reconnect cables.</li> <li>8. Replace the signal cable for the optical drive.</li> <li>9. Replace the optical drive.</li> </ol>

## Storage drive problems

Follow the suggested actions for the corresponding symptom in the order in which they are listed until the problem is solved. If none of these actions solve the problem, see “Troubleshooting procedure” on page 157 for the subsequent steps you should check after using the information in this topic. If the problem still cannot be solved, seek technical assistance. See Chapter 8 “Getting information, help, and service” on page 163.

### Notes:

- If you are instructed to remove, install, or replace any CRUs, refer to the related procedure in Chapter 6 “Replacing hardware” on page 59.

- The status LEDs on each hot-swap hard disk drive help you easily identify a problem. See “Hot-swap drive status LEDs” on page 41.

Symptom	Action
A newly installed hot-swap hard disk drive is not recognized.	<ol style="list-style-type: none"> <li>1. Ensure that the drive is installed into the correct drive bay.</li> <li>2. Restart the server.</li> <li>3. Remove the drive from the bay, wait 45 seconds, and reinsert the drive into the bay, making sure that the drive connects to the hot-swap hard-disk-drive backplane.</li> <li>4. Run any diagnostic programs to test the hard disk drive if you have.</li> <li>5. Ensure that the hot-swap hard-disk-drive backplane is correctly seated. When it is correctly seated, the drive assemblies correctly connect to the backplane without bowing or causing movement of the backplane.</li> <li>6. Ensure that the cable connection is correct. See “Connecting cables” on page 43.</li> <li>7. Reconnect the backplane power cable and repeat step 1 through step 4.</li> <li>8. Reconnect the backplane signal cable and repeat step 1 through step 4.</li> <li>9. If you suspect a problem with the backplane signal cable or the backplane:               <ol style="list-style-type: none"> <li>a. Replace the affected backplane signal cable.</li> <li>b. Replace the affected backplane.</li> </ol> </li> </ol>
Multiple hard disk drives fail.	<ol style="list-style-type: none"> <li>1. Ensure that the cable connection is correct. See “Connecting cables” on page 43.</li> <li>2. Reconnect the power cables.</li> <li>3. Reconnect the signal cables.</li> <li>4. Replace the affected signal cables.</li> <li>5. If you suspect a problem with the backplane, replace the affected backplane.</li> </ol>

## Memory module problems

Follow the suggested actions for the corresponding symptom in the order in which they are listed until the problem is solved. If none of these actions solve the problem, see “Troubleshooting procedure” on page 157 for the subsequent steps you should check after using the information in this topic. If the problem still cannot be solved, seek technical assistance. See Chapter 8 “Getting information, help, and service” on page 163.

### Notes:

- If you are instructed to remove, install, or replace any CRUs, refer to the related procedure in Chapter 6 “Replacing hardware” on page 59.
- If an action step is preceded by “(Trained service technician only),” this action step is reserved for a trained service technician and must be performed only by a trained service technician.

Symptom	Action
<p>The amount of system memory that is displayed is less than the total capacity of the installed physical memory modules and you suspect a memory module problem.</p>	<ol style="list-style-type: none"> <li>1. Ensure that: <ul style="list-style-type: none"> <li>• All memory modules are the correct type supported by the server. See “Memory module installation rules” on page 66.</li> <li>• You followed the memory module installation rules. See “Memory module installation rules” on page 66.</li> <li>• All memory modules are seated correctly and securely.</li> <li>• The system firmware is up-to-date.</li> </ul> </li> <li>2. Reinstall the memory modules.</li> <li>3. Replace the suspect memory modules.</li> <li>4. (Trained service technician only) Replace the system board.</li> </ol>

## Keyboard, mouse, and USB device problems

Follow the suggested actions for the corresponding symptom in the order in which they are listed until the problem is solved. If none of these actions solve the problem, see “Troubleshooting procedure” on page 157 for the subsequent steps you should check after using the information in this topic.

Symptom	Action
All or some keys on the keyboard do not work.	<ol style="list-style-type: none"> <li>1. Ensure that: <ul style="list-style-type: none"> <li>• The USB keyboard cable is securely connected to a USB connector on the server. If the USB keyboard is connected to a USB hub, disconnect the keyboard from the hub and connect it directly to the server.</li> <li>• No keys are stuck.</li> <li>• The USB controller is enabled in the Setup Utility program. See “Using the Setup Utility program” on page 47.</li> </ul> </li> <li>2. Restart the server.</li> <li>3. Replace the keyboard.</li> </ol>
The mouse or pointing device does not work.	<ol style="list-style-type: none"> <li>1. Ensure that: <ul style="list-style-type: none"> <li>• The mouse or pointing device cable is securely connected to the server. If the USB mouse or pointing device is connected to a USB hub, disconnect the mouse or pointing device from the hub and connect it directly to the server.</li> <li>• The mouse or pointing device is clean and no dust accumulates.</li> <li>• The device drivers are installed correctly.</li> <li>• The USB controller is enabled in the Setup Utility program. See “Using the Setup Utility program” on page 47.</li> </ul> </li> <li>2. Restart the server.</li> <li>3. Replace the mouse or pointing device.</li> </ol>
A USB device does not work.	<ol style="list-style-type: none"> <li>1. Ensure that: <ul style="list-style-type: none"> <li>• The USB cable is securely connected to the server. If the USB device is connected to a USB hub, disconnect the device from the hub and connect it directly to the server.</li> <li>• The device drivers are installed correctly.</li> <li>• The USB controller is enabled in the Setup Utility program. See “Using the Setup Utility program” on page 47.</li> </ul> </li> <li>2. Restart the server.</li> <li>3. Replace the USB device.</li> </ol>



---

## Chapter 8. Getting information, help, and service

This chapter contains information about help, service, and technical assistance for products manufactured by Lenovo and where to go for additional information about Lenovo and Lenovo products.

---

### Information resources

You can use the information in this topic to access useful resources relating to your needs when using the product.

### Using the documentation

To get the information about your Lenovo system, optional devices, and installed software, if any, go to the Lenovo Support Web site at <http://www.lenovo.com/support>.

For more information about your server documentation, see “Server documentation” on page 2.

If you suspect a software problem, refer to the documentation, including readme files and online help, that comes with the operating system or software program.

### ThinkServer Web site

The ThinkServer Web site provides up-to-date information and services to help you buy, use, upgrade, and maintain your server. You also can do the following by visiting the ThinkServer Web site at:

<http://www.lenovo.com/thinkserver>

- Shop for servers as well as upgrades and accessories for your server.
- Purchase additional services and software.
- Purchase upgrades and extended hardware repair services.
- Access the Lenovo Limited Warranty (LLW).
- Access the online manuals for your products.
- Access troubleshooting and support information for your server model and other supported products.
- Download the latest device drivers and software updates for your server model.
- Find the service and support phone numbers for your country or region.
- Find a Service Provider located near you.

### Lenovo Support Web site

Technical support information is available on the Lenovo Support Web site at:

<http://www.lenovo.com/support>

This Web site is updated with the latest support information such as the following:

- Drivers and software
- Diagnostic solutions
- Product and service warranty
- Product and parts details
- User guides and manuals
- Knowledge base and frequently asked questions

---

## Help and service

This topic contains information about obtaining help and service.

### Before you call

Before you call, do the following to try to solve the problem by yourself:

- Check all cables to ensure that they are connected.
- Check the power switches to ensure that the system and optional devices are turned on.
- Use the troubleshooting information in this manual. Go to Chapter 7 “Troubleshooting and diagnostics” on page 157.
- Check for the updated information, new device drivers, and hints and tips on the Lenovo Support Web site at:  
<http://www.lenovo.com/support>
- Download the diagnostic program from the Lenovo Web site, and then run it. See “Lenovo ThinkServer Diagnostics” on page 14.

If possible, be at your product when you call. Have the following information available:

- Machine type and model
- Serial numbers of your Lenovo hardware products
- Description of the problem
- Exact wording of any error messages
- Hardware and software configuration information

### Calling for service

During the warranty period, you can get help and information by telephone through the Customer Support Center.

The following services are available during the warranty period:

- **Problem determination** - Trained service personnel are available to assist you with determining a hardware problem and deciding what action is necessary to fix the problem.
- **Hardware repair** - If the problem is caused by hardware under warranty, trained service personnel are available to provide the applicable level of service.
- **Engineering Change management** - There might be changes that are required after a product has been sold. Lenovo or your reseller will make selected Engineering Changes (ECs) that apply to your hardware available.

The warranty does not cover the following:

- Replacement or use of parts not manufactured for or by Lenovo or non-warranted Lenovo parts
- Identification of software problem sources
- Configuration of the Unified Extensible Firmware Interface (UEFI) BIOS as part of an installation or upgrade
- Changes, modifications, or upgrades to device drivers
- Installation and maintenance of network operating systems (NOS)
- Installation and maintenance of application programs

For the warranty type and duration for your product, go to <http://www.lenovo.com/warranty>. You must retain your proof of purchase to obtain warranty service.

For warranty service, consult the worldwide Lenovo Support telephone list. Telephone numbers are subject to change without notice. The most up-to-date telephone list for Lenovo Support is always available on the Web site at <http://www.lenovo.com/support/phone>. If the telephone number for your country or region is not listed, contact your Lenovo reseller or Lenovo marketing representative.

## Using other services

If you travel with a Lenovo notebook computer or relocate your computer to a country where your desktop, notebook, or server machine type is sold, your computer might be eligible for International Warranty Service, which automatically entitles you to obtain warranty service throughout the warranty period. Service will be performed by service providers authorized to perform warranty service.

Service methods and procedures vary by country, and some services might not be available in all countries. International Warranty Service is delivered through the method of service (such as depot, carry-in, or on-site service) that is provided in the servicing country. Service centers in certain countries might not be able to service all models of a particular machine type. In some countries, fees and restrictions might apply at the time of service.

To determine whether your computer is eligible for International Warranty Service and to view a list of the countries where service is available, go to <http://www.lenovo.com/support>, click **Warranty**, and follow the instructions on the screen.

For technical assistance with the installation of or questions related to Service Packs for your installed Windows product, refer to the Microsoft Product Support Services Web site at <http://support.microsoft.com/directory> or you can contact the Customer Support Center. Some fees might apply.

## Purchasing additional services

During and after the warranty period, you can purchase additional services, such as support for hardware, operating systems, and application programs; network setup and configuration services; upgraded or extended hardware repair services; and custom installation services. Service availability and service names might vary by country or region. For more information about these services, go to the Lenovo Web site at: <http://www.lenovo.com>



---

## Appendix A. Regulatory information

The latest compliance information is available at <http://www.lenovo.com/compliance>.

---

### Export classification notice

This product is subject to the United States Export Administration Regulations (EAR) and has an Export Classification Control Number (ECCN) of 4A994.b. It can be re-exported except to any of the embargoed countries in the EAR E1 country list.

---

### Electronic emission notices

The following information refers to the Lenovo ThinkServer machine types 70CV, 70CW, 70CX, 70CY, 70R3, 70R4, 70R5, 70R6, 70S6, and 70S7. The latest compliance information is available at <http://www.lenovo.com/compliance>.

---

### Federal Communications Commission (FCC) Statement

This equipment has been tested and found to comply with the limits for a Class A digital device, pursuant to Part 15 of the FCC Rules. These limits are designed to provide reasonable protection against harmful interference when the equipment is operated in a commercial environment. This equipment generates, uses, and can radiate radio frequency energy and, if not installed and used in accordance with the instruction manual, may cause harmful interference to radio communications. Operation of this equipment in a residential area is likely to cause harmful interference in which case the user will be required to correct the interference at his own expense.

Properly shielded and grounded cables and connectors must be used in order to meet FCC emission limits. Lenovo is not responsible for any radio or television interference caused by using other than specified or recommended cables and connectors or by unauthorized changes or modifications to this equipment. Unauthorized changes or modifications could void the user's authority to operate the equipment.

This device complies with Part 15 of the FCC Rules. Operation is subject to the following two conditions: (1) this device may not cause harmful interference, and (2) this device must accept any interference received, including interference that may cause undesired operation.

### Industry Canada Compliance Statement

CAN ICES-3(A)/NMB-3(A)

### United Kingdom telecommunications safety requirement

Notice to Customers

This apparatus is approved under approval number NS/G/1234/J/100003 for indirect connection to public telecommunication systems in the United Kingdom.

### European Union - Compliance to the Electromagnetic Compatibility Directive

This product is in conformity with the protection requirements of EU Council Directive 2014/30/EU on the approximation of the laws of the Member States relating to electromagnetic compatibility. Lenovo cannot accept responsibility for any failure to satisfy the protection requirements resulting from a non-recommended modification of the product, including the installation of option cards from other manufacturers. This product

has been tested and found to comply with the limits for Class A equipment according to European Standards harmonized in the Directives in compliance. The limits for Class A equipment were derived for commercial and industrial environments to provide reasonable protection against interference with licensed communication equipment.

Lenovo, Einsteinova 21, 851 01 Bratislava, Slovakia



**Warning:** This is a Class A product. In a domestic environment this product may cause radio interference in which case the user may be required to take adequate measures.

### **German Class A compliance statement**

*Deutschsprachiger EU Hinweis:*

*Hinweis für Geräte der Klasse A EU Richtlinie zur Elektromagnetischen Verträglichkeit*

Dieses Produkt entspricht den Schutzanforderungen der EU Richtlinie 2014/30/EU zur Angleichung der Rechtsvorschriften über die elektromagnetische Verträglichkeit in den EU-Mitgliedsstaaten und hält die Grenzwerte der Klasse A der Norm gemäß Richtlinie.

Um dieses sicherzustellen, sind die Geräte wie in den Handbüchern beschrieben zu installieren und zu betreiben. Des Weiteren dürfen auch nur von der Lenovo empfohlene Kabel angeschlossen werden. Lenovo übernimmt keine Verantwortung für die Einhaltung der Schutzanforderungen, wenn das Produkt ohne Zustimmung der Lenovo verändert bzw. wenn Erweiterungskomponenten von Fremdherstellern ohne Empfehlung der Lenovo gesteckt/eingebaut werden.

*Deutschland:*

*Einhaltung des Gesetzes über die elektromagnetische Verträglichkeit von Betriebsmitteln*

Dieses Produkt entspricht dem „Gesetz über die elektromagnetische Verträglichkeit von Betriebsmitteln“ EMVG (früher „Gesetz über die elektromagnetische Verträglichkeit von Geräten“). Dies ist die Umsetzung der EMV EU Richtlinie 2014/30/EU in der Bundesrepublik Deutschland.

*Zulassungsbescheinigung laut dem Deutschen Gesetz über die elektromagnetische Verträglichkeit von Betriebsmitteln, EMVG vom 20. Juli 2007 (früher Gesetz über die elektromagnetische Verträglichkeit von Geräten), bzw. der EMV EU Richtlinie 2014/30/EU, für Geräte der Klasse A.*

Dieses Gerät ist berechtigt, in Übereinstimmung mit dem Deutschen EMVG das EG-Konformitätszeichen - CE - zu führen. Verantwortlich für die Konformitätserklärung nach Paragraf 5 des EMVG ist die Lenovo (Deutschland) GmbH, Meitnerstr. 9, D-70563 Stuttgart.

Informationen in Hinsicht EMVG Paragraf 4 Abs. (1) 4:

*Das Gerät erfüllt die Schutzanforderungen nach EN 55024 und EN 55032 Klasse A.*

Nach der EN 55032: „Dies ist eine Einrichtung der Klasse A. Diese Einrichtung kann im Wohnbereich Funkstörungen verursachen; in diesem Fall kann vom Betreiber verlangt werden, angemessene Maßnahmen durchzuführen und dafür aufzukommen.“

Nach dem EMVG: „Geräte dürfen an Orten, für die sie nicht ausreichend entstört sind, nur mit besonderer Genehmigung des Bundesministers für Post und Telekommunikation oder des Bundesamtes für Post und Telekommunikation betrieben werden. Die Genehmigung wird erteilt, wenn keine elektromagnetischen Störungen zu erwarten sind.“ (Auszug aus dem EMVG, Paragraph 3, Abs. 4). Dieses Genehmigungsverfahren

ist nach Paragraph 9 EMVG in Verbindung mit der entsprechenden Kostenverordnung (Amtsblatt 14/93) kostenpflichtig.

Anmerkung: Um die Einhaltung des EMVG sicherzustellen sind die Geräte, wie in den Handbüchern angegeben, zu installieren und zu betreiben.

### Korea Class A compliance statement

A급 기기 (업무용 방송통신기자재)
이 기기는 업무용(A급) 전자파적합기기로서 판매자 또는 사용자는 이 점을 주의하시기 바라며, 가정외의 지역에서 사용하는 것을 목적으로 합니다.

### Russia Electromagnetic Interference (EMI) Class A statement

#### ВНИМАНИЕ!

Настоящее изделие относится к оборудованию класса А. При использовании в бытовой обстановке это оборудование может нарушать функционирование других технических средств в результате создаваемых промышленных радиопомех. В этом случае от пользователя может потребоваться принятие адекватных мер.

### Taiwan Class A compliance statement

#### 警告使用者

此為甲類資訊技術設備，於居住環境中使用時，可能會造成射頻擾動，在此種情況下，使用者會被要求採取某些適當的對策。

### Lenovo product service information for Taiwan

委製商/進口商名稱: 台灣聯想環球科技股份有限公司  
進口商地址: 台北市南港區三重路 66 號 8 樓  
進口商電話: 0800-000-702

### Japan VCCI Class A compliance statement

この装置は、クラスA情報技術装置です。この装置を家庭環境で使用すると電波妨害を引き起こすことがあります。この場合には使用者が適切な対策を講ずるよう要求されることがあります。 V C C I - A

### 通信規制の注記

This product may not be certified in your country for connection by any means whatsoever to interfaces of public telecommunications networks. Further certification may be required by law prior to making any such connection. Contact a Lenovo representative or reseller for any questions.

本製品は、電気通信事業者の通信回線との責任分界点への、直接的な接続を想定した認定取得作業を行っていません。そのような接続を行うには、電気通信事業者による事前検査等が必要となる場合があります。ご不明な点については、Lenovo担当員または販売代理店にお問い合わせください。

## Japanese statement for ac power consumption for JEITA harmonics guideline

定格入力電力表示

(社) 電子情報技術参照委員会 家電・汎用品高調波抑制対策ガイドライン  
実行計画書に基づく定格入力電力値: W

お手持ちのユニットの定格入力電力値 (W) はユニットの電源装置に貼付されている電源仕様ラベルをご参照下さい

## Japanese statement of compliance for products less than or equal to 20 A per phase for JEITA harmonics guideline

日本の定格電流が 20A/相 以下の機器に対する高調波電流規制  
高調波電流規格 JIS C 61000-3-2 適合品

---

## Eurasian compliance mark





---

## Appendix B. WEEE and recycling information

Lenovo encourages owners of information technology (IT) equipment to responsibly recycle their equipment when it is no longer needed. Lenovo offers a variety of programs and services to assist equipment owners in recycling their IT products. For information on recycling Lenovo products, go to <http://www.lenovo.com/recycling>. The latest environmental information about our products is available at <http://www.lenovo.com/ecodeclaration>.

---

### Important WEEE information

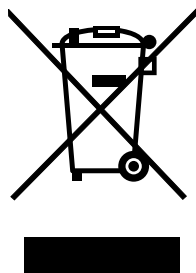

The WEEE marking on Lenovo products applies to countries with WEEE and e-waste regulations (for example, the European WEEE Directive, India E-Waste Management & Handling Rules, 2011). Appliances are labeled in accordance with local regulations concerning waste electrical and electronic equipment (WEEE). These regulations determine the framework for the return and recycling of used appliances as applicable within each geography. This label is applied to various products to indicate that the product is not to be thrown away, but rather put in the established collection systems for reclaiming these end of life products.

Users of electrical and electronic equipment (EEE) with the WEEE marking must not dispose of end of life EEE as unsorted municipal waste, but use the collection framework available to them for the return, recycle, and recovery of WEEE and to minimize any potential effects of EEE on the environment and human health due to the presence of hazardous substances. Lenovo electrical and electronic equipment (EEE) may contain parts and components, which at end-of-life might qualify as hazardous waste.

EEE and waste electrical and electronic equipment (WEEE) can be delivered free of charge to the place of sale or any distributor that sells electrical and electronic equipment of the same nature and function as the used EEE or WEEE.

For additional WEEE information, go to:  
<http://www.lenovo.com/recycling>

#### WEEE information for Hungary

Lenovo, as a producer, bears the cost incurred in connection with the fulfillment of Lenovo's obligations under Hungary Law No. 197/2014 (VIII.1.) subsections (1)-(5) of section 12.

---

### Recycling information for Japan

#### Collecting and recycling a disused Lenovo computer or monitor

If you are a company employee and need to dispose of a Lenovo computer or monitor that is the property of the company, you must do so in accordance with the Law for Promotion of Effective Utilization of Resources. Computers and monitors are categorized as industrial waste and should be properly disposed of by an

industrial waste disposal contractor certified by a local government. In accordance with the Law for Promotion of Effective Utilization of Resources, Lenovo Japan provides, through its PC Collecting and Recycling Services, for the collecting, reuse, and recycling of disused computers and monitors. For details, visit the Lenovo Web site at <http://www.lenovo.com/recycling/japan>. Pursuant to the Law for Promotion of Effective Utilization of Resources, the collecting and recycling of home-used computers and monitors by the manufacturer was begun on October 1, 2003. This service is provided free of charge for home-used computers sold after October 1, 2003. For details, visit the Lenovo Web site at <http://www.lenovo.com/recycling/japan>.

### **Disposing of Lenovo computer components**

Some Lenovo computer products sold in Japan may have components that contain heavy metals or other environmental sensitive substances. To properly dispose of disused components, such as a printed circuit board or drive, use the methods described above for collecting and recycling a disused computer or monitor.

### **Disposing of disused lithium batteries from Lenovo computers**

A button-shaped lithium battery is installed inside your Lenovo computer to provide power to the computer clock while the computer is off or disconnected from the main power source. If you need to replace it with a new one, contact your place of purchase or contact Lenovo for service. If you need to dispose of a disused lithium battery, insulate it with vinyl tape, contact your place of purchase or an industrial-waste-disposal operator, and follow their instructions. Disposal of a lithium battery must comply with local ordinances and regulations.

---

## **Recycling information for Brazil**

### **Declarações de Reciclagem no Brasil**

#### **Descarte de um Produto Lenovo Fora de Uso**

Equipamentos elétricos e eletrônicos não devem ser descartados em lixo comum, mas enviados à pontos de coleta, autorizados pelo fabricante do produto para que sejam encaminhados e processados por empresas especializadas no manuseio de resíduos industriais, devidamente certificadas pelos órgãos ambientais, de acordo com a legislação local.

A Lenovo possui um canal específico para auxiliá-lo no descarte desses produtos. Caso você possua um produto Lenovo em situação de descarte, ligue para o nosso SAC ou encaminhe um e-mail para: [reciclar@lenovo.com](mailto:reciclar@lenovo.com), informando o modelo, número de série e cidade, a fim de enviarmos as instruções para o correto descarte do seu produto Lenovo.

---

## **Battery recycling information for the European Union**

EU

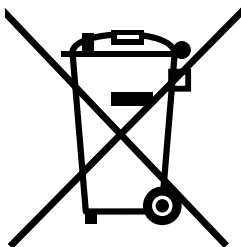

**Notice:** This mark applies only to countries within the European Union (EU).

Batteries or packaging for batteries are labeled in accordance with European Directive 2006/66/EC concerning batteries and accumulators and waste batteries and accumulators. The Directive determines the framework for the return and recycling of used batteries and accumulators as applicable throughout the European Union. This label is applied to various batteries to indicate that the battery is not to be thrown away, but rather reclaimed upon end of life per this Directive.

In accordance with the European Directive 2006/66/EC, batteries and accumulators are labeled to indicate that they are to be collected separately and recycled at end of life. The label on the battery may also include a chemical symbol for the metal concerned in the battery (Pb for lead, Hg for mercury, and Cd for cadmium). Users of batteries and accumulators must not dispose of batteries and accumulators as unsorted municipal waste, but use the collection framework available to customers for the return, recycling, and treatment of batteries and accumulators. Customer participation is important to minimize any potential effects of batteries and accumulators on the environment and human health due to the potential presence of hazardous substances.

Before placing electrical and electronic equipment (EEE) in the waste collection stream or in waste collection facilities, the end user of equipment containing batteries and/or accumulators must remove those batteries and accumulators for separate collection.

### **Disposing of lithium batteries and battery packs from Lenovo products**

A coin-cell type lithium battery might be installed inside your Lenovo product. You can find details about the battery in the product documentation. If the battery needs to be replaced, contact your place of purchase or contact Lenovo for service. If you need to dispose of a lithium battery, insulate it with vinyl tape, contact your place of purchase or a waste-disposal operator, and follow their instructions.

### **Disposing of battery packs from Lenovo products**

Your Lenovo device might contain a lithium-ion battery pack or a nickel metal hydride battery pack. You can find details on the battery pack in the product documentation. If you need to dispose of a battery pack, insulate it with vinyl tape, contact Lenovo sales, service, or your place of purchase, or a waste-disposal operator, and follow their instructions. You also can refer to the instructions provided in the user guide for your product

For proper collection and treatment, go to:  
<http://www.lenovo.com/lenovo/environment>

---

## **Battery recycling information for the United States and Canada**

This product may contain a lithium or lithium ion battery. Consult your user manual or service manual for specific battery information. The battery must be recycled or disposed of properly. Recycling facilities may not be available in your area. For information on disposal or batteries outside the United States, go to <http://www.lenovo.com/recycling> or contact your local waste disposal facility.



**US & Canada Only**

---

## **Requirement for batteries containing perchlorate**

The following statement applies to users in the state of California, U.S.A.

California Perchlorate Information:

Products containing CR (manganese dioxide) lithium coin cell batteries may contain perchlorate.

Perchlorate Material - special handling may apply, See  
<http://www.dtsc.ca.gov/hazardouswaste/perchlorate>

---

## Appendix C. Restriction of Hazardous Substances (RoHS) Directive

This topic provides statements about the Restriction of Hazardous Substances (RoHS) Directive. The latest environmental information is available at <http://www.lenovo.com/ecodeclaration>.

---

### European Union RoHS

This Lenovo product, with included parts (cables, cords, and so on) meets the requirements of Directive 2011/65/EU on the restriction of the use of certain hazardous substances in electrical and electronic equipment (“RoHS recast” or “RoHS 2”).

For more information about Lenovo worldwide compliance on RoHS, go to: [http://www.lenovo.com/social\\_responsibility/us/en/RoHS\\_Communication.pdf](http://www.lenovo.com/social_responsibility/us/en/RoHS_Communication.pdf)

---

### Turkish RoHS

The Lenovo product meets the requirements of the Republic of Turkey Directive on the Restriction of the Use of Certain Hazardous Substances in Waste Electrical and Electronic Equipment (WEEE).

#### Türkiye AEEE Yönetmeliğine Uygunluk Beyanı

Bu Lenovo ürünü, T.C. Çevre ve Orman Bakanlığı'nın “Atık Elektrik ve Elektronik Eşyalarda Bazı Zararlı Maddelerin Kullanımının Sınırlandırılmasına Dair Yönetmelik (AEEE)” direktiflerine uygundur.

AEEE Yönetmeliğine Uygundur.

---

### Ukraine RoHS

Цим підтверджуємо, що продукція Леново відповідає вимогам нормативних актів України, які обмежують вміст небезпечних речовин

---

### India RoHS

RoHS compliant as per E-Waste (Management) Rules.

## China RoHS

部件名称	有害物质					
	铅 (Pb)	汞 (Hg)	镉 (Cd)	六价铬 (Cr(VI))	多溴联苯 (PBB)	多溴二苯醚 (PBDE)
机架	0	0	0	0	0	0
外部盖板	0	0	0	0	0	0
机械组合件	X	0	0	0	0	0
空气传动设备	X	0	0	0	0	0
冷却组合件	X	0	0	0	0	0
内存模块	X	0	0	0	0	0
处理器模块	X	0	0	0	0	0
键盘	X	0	0	0	0	0
调制解调器	X	0	0	0	0	0
监视器	X	0	0	0	0	0
鼠标	X	0	0	0	0	0
电缆组合件	X	0	0	0	0	0
电源	X	0	0	0	0	0
存储设备	X	0	0	0	0	0
电池匣组合件	X	0	0	0	0	0
电池	X	0	0	0	0	0
有mech的电路卡	X	0	0	0	0	0
无mech的电路卡	X	0	0	0	0	0
激光器	X	0	0	0	0	0

本表格依据 SJ/T 11364 的规定编制。  
 0：表示该有害物质在该部件所有均质材料中的含量均在 GB/T 26572 规定的限量要求以下。  
 X：表示该有害物质至少在该部件的某一均质材料中的含量超出 GB/T 26572 规定的限量要求。  
 注：表中标记“X”的部件，皆因全球技术发展水平限制而无法实现有害物质的替代。

**环保使用期限 (EPUP) 的免责条款：EPUP 规定的具体期限仅为符合中华人民共和国的相应的法律规定，并非代表 Lenovo 向客户提供保证或负有任何义务。EPUP 中假定客户按照操作手册在正常情况下使用本产品。对于本产品中配备的某些组合件（例如，装有电池的组件）的 EPUP，其效力可能低于本产品的 EPUP。**

Environmental Protection Use Period (EPUP) Disclaimer: The number provided as the EPUP is provided solely to comply with applicable laws of the People's Republic of China. It does not create any warranties or liabilities on behalf of Lenovo to customer. The EPUP assumes that the product will be used under normal conditions in accordance with the Lenovo operating manual. Certain assemblies inside this product (for example, assemblies that contain a battery) may have an EPUP which is lower than the EPUP on this product.

## Taiwan BSMI RoHS declaration

單元 Unit	限用物質及其化學符號 Restricted substances and its chemical symbols					
	鉛Lead (Pb)	汞Mercury (Hg)	鎘Cadmium (Cd)	六價鉻 Hexavalent chromium (Cr <sup>6+</sup> )	多溴聯苯 Polybrominated biphenyls (PBB)	多溴二苯醚 Polybrominated diphenyl ethers (PBDE)
機架	○	○	○	○	○	○
外部蓋板	○	○	○	○	○	○
機械組零件	-	○	○	○	○	○
空氣傳動設備	-	○	○	○	○	○
冷卻組零件	-	○	○	○	○	○
內存模塊	-	○	○	○	○	○
處理器模塊	-	○	○	○	○	○
電纜組零件	-	○	○	○	○	○
電源	-	○	○	○	○	○
儲備設備	-	○	○	○	○	○
電路卡	-	○	○	○	○	○
光碟機	-	○	○	○	○	○
雷射器	-	○	○	○	○	○

備考1. “超出0.1 wt%”及“超出0.01 wt%”係指限用物質之百分比含量超出百分比含量基準值。  
 Note1: “exceeding 0.1 wt%” and “exceeding 0.01 wt%” indicate that the percentage content of the restricted substance exceeds the reference percentage value of presence condition.

備考2. “○”係指該項限用物質之百分比含量未超出百分比含量基準值。  
 Note2: “○”indicates that the percentage content of the restricted substance does not exceed the percentage of reference value of presence.

備考3. “-”係指該項限用物質為排除項目。  
 Note3: The “-” indicates that the restricted substance corresponds to the exemption.





---

## Appendix D. Additional statements

---

### Important notes

Processor speed indicates the internal clock speed of the microprocessor; other factors also affect application performance.

CD or DVD drive speed is the variable read rate. Actual speeds vary and are often less than the possible maximum.

When referring to processor storage, real and virtual storage, or channel volume, KB stands for 1 024 bytes, MB stands for 1 048 576 bytes, and GB stands for 1 073 741 824 bytes.

When referring to hard disk drive capacity or communications volume, MB stands for 1 000 000 bytes, and GB stands for 1 000 000 000 bytes. Total user-accessible capacity can vary depending on operating environments.

Maximum internal hard disk drive capacities assume the replacement of any standard hard disk drives and population of all hard-disk-drive bays with the largest currently supported drives that are available from Lenovo.

Maximum memory might require replacement of the standard memory with an optional memory module.

Lenovo makes no representations or warranties with respect to non-Lenovo products. Support (if any) for the non-Lenovo products is provided by the third party, not Lenovo.

Some software might differ from its retail version (if available) and might not include user manuals or all program functionality.

---

### Particulate contamination

**Attention:** Airborne particulates (including metal flakes or particles) and reactive gases acting alone or in combination with other environmental factors such as humidity or temperature might pose a risk to the server that is described in this document. Risks that are posed by the presence of excessive particulate levels or concentrations of harmful gases include damage that might cause the server to malfunction or cease functioning altogether. This specification sets forth limits for particulates and gases that are intended to avoid such damage. The limits must not be viewed or used as definitive limits, because numerous other factors, such as temperature or moisture content of the air, can influence the impact of particulates or environmental corrosives and gaseous contaminant transfer. In the absence of specific limits that are set forth in this document, you must implement practices that maintain particulate and gas levels that are consistent with the protection of human health and safety. If Lenovo determines that the levels of particulates or gases in your environment have caused damage to the server, Lenovo may condition provision of repair or replacement of servers or parts on implementation of appropriate remedial measures to mitigate such environmental contamination. Implementation of such remedial measures is a customer responsibility.

Table 3. Limits for particulates and gases

Contaminant	Limits
Particulate	<ul style="list-style-type: none"> <li>The room air must be continuously filtered with 40% atmospheric dust spot efficiency (MERV 9) according to ASHRAE Standard 52.2<sup>1</sup>.</li> <li>Air that enters a data center must be filtered to 99.97% efficiency or greater, using high-efficiency particulate air (HEPA) filters that meet MIL-STD-282.</li> <li>The deliquescent relative humidity of the particulate contamination must be more than 60%<sup>2</sup>.</li> <li>The room must be free of conductive contamination such as zinc whiskers.</li> </ul>
Gaseous	<ul style="list-style-type: none"> <li>Copper: Class G1 as per ANSI/ISA 71.04-1985<sup>3</sup></li> <li>Silver: Corrosion rate of less than 300 Å in 30 days</li> </ul>
<p><sup>1</sup> ASHRAE 52.2-2008 - <i>Method of Testing General Ventilation Air-Cleaning Devices for Removal Efficiency by Particle Size</i>. Atlanta: American Society of Heating, Refrigerating and Air-Conditioning Engineers, Inc.</p> <p><sup>2</sup> The deliquescent relative humidity of particulate contamination is the relative humidity at which the dust absorbs enough water to become wet and promote ionic conduction.</p> <p><sup>3</sup> ANSI/ISA-71.04-1985. <i>Environmental conditions for process measurement and control systems: Airborne contaminants</i>. Instrument Society of America, Research Triangle Park, North Carolina, U.S.A.</p>	

## German Ordinance for Work gloss statement

The product is not suitable for use with visual display work place devices according to clause 2 of the German Ordinance for Work with Visual Display Units.

Das Produkt ist nicht für den Einsatz an Bildschirmarbeitsplätzen im Sinne § 2 der Bildschirmarbeitsverordnung geeignet.

---

## Appendix E. ENERGY STAR model information



ENERGY STAR® is a joint program of the U.S. Environmental Protection Agency and the U.S. Department of Energy aimed at saving money and protecting the environment through energy efficient products and practices.

Lenovo is proud to offer our customers products with an ENERGY STAR compliant designation. Some models of the following machine types have been designed and tested to conform to the ENERGY STAR program requirement for computer servers at the time of manufacture: 70CV, 70CW, 70CX, 70CY, 70R3, 70R4, 70R5, 70R6, 70S6, and 70S7.

For more information about ENERGY STAR ratings for Lenovo servers, go to <http://www.lenovo.com>.

By using ENERGY STAR compliant products and taking advantage of the power-management features of your server, you reduce the consumption of electricity. Reduced electrical consumption contributes to potential financial savings, a cleaner environment, and the reduction of greenhouse gas emissions.

For more information about ENERGY STAR, go to:  
<http://www.energystar.gov>

Lenovo encourages you to make efficient use of energy an integral part of your day-to-day operations. To help in this endeavor, set the following power-management features to take effect when your servers have been used:

- Processor- or core-reduced power states
- Variable speed fan control based on power or thermal readings
- Low power memory states



---

## Appendix F. Notices

Lenovo may not offer the products, services, or features discussed in this document in all countries. Consult your local Lenovo representative for information on the products and services currently available in your area. Any reference to a Lenovo product, program, or service is not intended to state or imply that only that Lenovo product, program, or service may be used. Any functionally equivalent product, program, or service that does not infringe any Lenovo intellectual property right may be used instead. However, it is the user's responsibility to evaluate and verify the operation of any other product, program, or service.

Lenovo may have patents or pending patent applications covering subject matter described in this document. The furnishing of this document does not give you any license to these patents. You can send license inquiries, in writing, to:

*Lenovo (United States), Inc.  
1009 Think Place - Building One  
Morrisville, NC 27560  
U.S.A.  
Attention: Lenovo Director of Licensing*

LENOVO PROVIDES THIS PUBLICATION "AS IS" WITHOUT WARRANTY OF ANY KIND, EITHER EXPRESS OR IMPLIED, INCLUDING, BUT NOT LIMITED TO, THE IMPLIED WARRANTIES OF NON-INFRINGEMENT, MERCHANTABILITY OR FITNESS FOR A PARTICULAR PURPOSE. Some jurisdictions do not allow disclaimer of express or implied warranties in certain transactions, therefore, this statement may not apply to you.

This information could include technical inaccuracies or typographical errors. Changes are periodically made to the information herein; these changes will be incorporated in new editions of the publication. Lenovo may make improvements and/or changes in the product(s) and/or the program(s) described in this publication at any time without notice.

The products described in this document are not intended for use in implantation or other life support applications where malfunction may result in injury or death to persons. The information contained in this document does not affect or change Lenovo product specifications or warranties. Nothing in this document shall operate as an express or implied license or indemnity under the intellectual property rights of Lenovo or third parties. All information contained in this document was obtained in specific environments and is presented as an illustration. The result obtained in other operating environments may vary.

Lenovo may use or distribute any of the information you supply in any way it believes appropriate without incurring any obligation to you.

Any references in this publication to non-Lenovo Web sites are provided for convenience only and do not in any manner serve as an endorsement of those Web sites. The materials at those Web sites are not part of the materials for this Lenovo product, and use of those Web sites is at your own risk.

Any performance data contained herein was determined in a controlled environment. Therefore, the result obtained in other operating environments may vary significantly. Some measurements may have been made on development-level systems and there is no guarantee that these measurements will be the same on generally available systems. Furthermore, some measurements may have been estimated through extrapolation. Actual results may vary. Users of this document should verify the applicable data for their specific environment.

---

## Trademarks

Lenovo, the Lenovo logo, ThinkServer, the ThinkServer logo, System x, NeXtScale, and Flex System are trademarks of Lenovo in the United States, other countries, or both.

Intel and Intel Xeon are trademarks of Intel Corporation or its subsidiaries in the United States, other countries, or both.

Internet Explorer, Microsoft, and Windows are trademarks of the Microsoft group of companies.

Linux is a registered trademark of Linus Torvalds.

Other company, product, or service names may be trademarks or service marks of others.

---

# Index

- 2.5-inch drive
  - installing 131–132
  - replacing 131, 134
- 2.5-inch drive backplane
  - locations 33–34
- 3.5-inch drive backplane
  - locations 32

## A

- about RAID 55
- advanced SATA or SAS hardware RAID
  - configuring 56
- Advanced Settings menu
  - Setup Utility program 48
- AnyFabric adapter
  - installing 88
  - removing 90
- AnyFabric slot
  - Rear view 22
- AnyRAID adapter
  - locations 27, 31
  - replacing 108

## B

- BIOS and TSM update utilities
  - software 12
- Boot Manager menu
  - Setup Utility program 49

## C

- cables
  - connecting 43
- coin-cell battery
  - replacing 149
- configuring
  - server 47
- configuring RAID
  - advanced SATA or SAS hardware RAID 56
  - using the Lenovo ThinkServer Deployment Manager program 56
- configuring the server 47
- connect
  - external tape drive 139
- connecting
  - cables 43
- considerations, password 50
- contamination, particulate and gaseous 179
- cooling shroud
  - reinstalling 65
  - removing 64
- CRU
  - completing the replacement 154

## D

- devices, handling static-sensitive 60
- DIMM
  - installation rules 66
  - installing 68
  - removing 70

- documentation
  - using 163

## E

- easy-swap drive
  - installing 129
  - replacing 129
- Ethernet connectivity
  - features 9
- Ethernet connector
  - Setup Utility program 52
- Ethernet status
  - LED 22
- exiting
  - Setup Utility program 52
- expansion slots
  - features 8
- export classification notice 167
- external tape drive
  - connect 139

## F

- features 7
  - Lenovo ThinkServer Deployment Manager program 13
- firmware
  - updating 57
- flashing
  - the BIOS 53
- front panel
  - LED 19
  - locations 19
- front panel board
  - replacing 143
- front VGA and USB module
  - replacing 145
- front view of the server
  - locations 17

## G

- gaseous contamination 179
- German gloss statement 180
- getting help 163
- getting information 163
- getting service 163
- guidelines 59

## H

- hardware
  - replacing 59
- heat sink
  - installing or replacing 113
- help, getting 163
- Host Bus Adapter (HBA) 27, 31
- hot-swap hard disk drive
  - installing 126
  - replacing 126
- hot-swap hard-disk-drive backplane
  - replacing 140
- hot-swap redundant power supply

- installing 124
- replacing 125
- hot-swap-drive backplane
  - locations 31
- hot-swap-drive status
  - LED 41
- hot-swap-drive status LEDs
  - locations 41

## I

- ID
  - LED 20
- information, getting 163
- Input/Output (I/O)
  - features 8
- installation rules
  - DIMM 66
  - memory module 66
- installing
  - 2.5-inch drive 131–132
  - AnyFabric adapter 88
  - DIMM 68
  - easy-swap drive 129
  - hot-swap hard disk drive 126
  - hot-swap redundant power supply 124
  - intrusion switch 111
  - M.2 storage module 85
  - memory module 68
  - microprocessor 115
  - optical module 101
  - RAID 110i key 75
  - RAID upgrade key 78
  - rear backplane/cage kit 104
  - SD module 82
  - server cover 155
  - ThinkServer RAID Super Capacitor Module 91
  - ThinkServer Trusted Platform Module 73
  - TMM 80
  - TSM Premium module 71
- installing or replacing
  - heat sink 113
  - optical drive 137
- interface
  - Setup Utility program 47
- internal drives
  - features 8
- intrusion switch
  - installing 111
  - removing 112

## J

- Japanese statement for ac power consumption for JEITA harmonics guideline 170

## L

- LED
  - Ethernet status 22
  - front panel 19
  - hot-swap-drive status 41
  - ID 20
  - Network status 19
  - power status 20
  - power supply status 42
  - System fan fault 40
  - system health 19
- Lenovo Partner Pack for Microsoft System Center Operations Management

- software 13
- Lenovo ThinkServer Deployment Manager
  - software 13
- Lenovo ThinkServer Deployment Manager program
  - features 13
- Lenovo ThinkServer Power Planner
  - software 14
- Lenovo ThinkServer System Manager
  - software 15
- Lenovo ThinkServer System Manager Premium
  - software 15
- Lenovo XClarity Energy Manager
  - software 15
- locations 16

## M

- M.2 storage module
  - installing 85
  - removing 86
- machine type and model label
  - locations 16
- memory
  - features 7
- memory module
  - installation rules 66
  - installing 68
  - removing 70
- memory module installation
  - guidelines 66
- microprocessor
  - features 7
  - installing 115
  - replacing 119

## N

- Network status
  - LED 19

## O

- optical drive
  - installing or replacing 137
- optical module
  - installing 101
  - removing 102
- option
  - completing the replacement 154

## P

- particulate contamination 179
- parts replacement, completing 154
- password
  - considerations 50
  - setting, changing, deleting 51
  - Setup Utility program 50
- PCIe interposer card 27, 31
- power status
  - LED 20
- power supply
  - features 7
- power supply status
  - LED 42
- power supply status LEDs
  - locations 42
- precautions
  - guidelines 59



## R

- RAID
  - configuring 54
  - introduction 55
- RAID 110i key
  - installing 75
  - removing 76
- RAID upgrade key
  - installing 78
  - removing 79
- rear backplane
  - replacing 106
- rear backplane for up to two 2.5-inch drives
  - locations 34
- rear backplane/cage kit
  - installing 104
  - removing 105
- Rear view
  - AnyFabric slot 22
- rear view of the server
  - locations 21
- recovering
  - the BIOS 53
- reinstalling
  - cooling shroud 65
- reliability, availability, and serviceability
  - features 9
- removing
  - AnyFabric adapter 90
  - cooling shroud 64
  - DIMM 70
  - intrusion switch 111–112
  - M.2 storage module 86
  - memory module 70
  - optical module 102
  - RAID 110i key 76
  - RAID upgrade key 79
  - rear backplane/cage kit 105
  - SD module 83
  - server cover 61
  - ThinkServer RAID Super Capacitor Module 91–92
  - ThinkServer Trusted Platform Module 74
  - TMM 81
  - TSM Premium module 72
- replacing
  - 2.5-inch drive 131, 134
  - AnyRAID adapter 108
  - coin-cell battery 149
  - easy-swap drive 129
  - front panel board 143
  - front VGA and USB module 145
  - hardware 59
  - hot-swap hard disk drive 126
  - hot-swap hard-disk-drive backplane 140
  - hot-swap redundant power supply 125
  - microprocessor 119
  - rear backplane 106
  - riser card assembly 147
  - system board 150
  - system fan 142
- riser card assembly
  - replacing 147
- road map
  - server setup 5

- locations 16
- server components
  - locations 24
- server configuration
  - updating 156
- server cover
  - installing 155
  - removing 61
- server documentation 2
- server package 7
- server setup
  - road map 5
- service, getting 163
- setting, changing, deleting
  - password 51
- Setup Utility program
  - Ethernet connector 52
  - exiting 52
  - interface 47
  - password 50
  - starting 47
  - TPM 52
  - using 47
- slim optical drive
  - locations 17
- software 12
  - Lenovo ThinkServer Deployment Manager 13
- specifications 11
- starting
  - Setup Utility program 47
- startup device
  - selecting 51
  - Setup Utility program 51
- static-sensitive devices
  - guidelines 60
- static-sensitive devices, handling 60
- system board 35
  - replacing 150
- system board components
  - locations 35
- system board switches
  - locations 38
- system date
  - setting 50
- system event log
  - troubleshooting and diagnostics 158
- system fan
  - replacing 142
- System fan fault
  - LED 40
- System fan fault LEDs
  - locations 40
- system fans
  - features 8
- system health
  - LED 19
- System Information menu
  - Setup Utility program 48
- system reliability
  - guidelines 60
- System Security menu
  - Setup Utility program 49
- system time
  - setting 50

## T

- Taiwan BSMI RoHS declaration 177
- the BIOS
  - flashing 53
  - recovering 53
  - updating 53
  - updating or recovering 53

## S

- Save & Exit menu
  - Setup Utility program 49
- SD module
  - installing 82
  - removing 83
- serial number label

- ThinkServer RAID Super Capacitor Module
  - installing 91
  - removing 91–92
- ThinkServer Trusted Platform Module
  - installing 73
  - removing 74
- ThinkServer Web address 1
- TMM
  - installing 80
  - removing 81
- TPM
  - Setup Utility program 52
- troubleshooting and diagnostics
  - hard disk drive problems 159
  - keyboard, mouse, and USB device problems 161
  - Lenovo ThinkServer Deployment Manager program problems 158
  - memory module problems 160
  - optical drive problems 158
  - status and diagnostic LEDs 157
  - system event log 158
  - troubleshooting procedure 157
- TSM Premium module
  - installing 71
  - removing 72
- TSM Settings menu
  - Setup Utility program 49
- turning off the server 45
- turning on the server 45
- TÜV gloss statement 180

## U

- updating
  - firmware 57
  - server configuration 156
  - the BIOS 53
- updating or recovering
  - the BIOS 53
- using
  - documentation 163
  - passwords 50
  - Setup Utility program 47

## V

- video subsystem
  - features 9
- viewing information
  - Setup Utility program 47

## W

- Web site
  - compatible options 66
- working inside the server with the power on guidelines 61



**Lenovo™**