

Lenovo Storage D3284

Getting Started

MT: 6413

Read all the safety and health information in these instructions. Failure to follow instructions and properly set up, use and care for this product can increase the risk of serious injury or death, or damage to the device or devices. Please see the Lenovo Storage D3284 Hardware Installation and Maintenance Guide for full installation and configuration information.

Introduction

Important: The enclosure must be mounted in a rack.

Safe handling

- An unpopulated enclosure can weigh up to 45kg (100lb). Use appropriate lifting methods.
- A fully populated enclosure weighs 135kg (298lb). Only lift the enclosure when the drawers are empty and latched closed. Do not attempt to lift the enclosure when populated with drives.
- Do not lift the enclosure by the handles on the rear modules. They are not designed to take the weight. Only lift from underneath the main chassis.
- When closing the drawers, do so firmly, ensuring the latches are engaged.

Safety

- This equipment is for installation in a Restricted Access Location only.



Caution: If this equipment is used in a manner not specified by the manufacturer, the protection provided by the equipment may be impaired.

- All rear modules are part of the fire enclosure and must only be removed when a replacement can be immediately added. The system must not be run without all modules in place.
- Unplug the unit before you move it or if you think it has become damaged in any way.
- A safe electrical ground connection must be provided to the power supply cords.
- **Important:** The enclosure must be grounded before applying power.
- The plug on the power supply cord is used as the main disconnect device. Ensure that the socket outlets are located near the equipment and are easily accessible.
- When powered by multiple AC sources, disconnect all supply power for complete isolation.
- In order to comply with applicable safety, emission and thermal requirements no covers should be removed and all rear bays must be populated with plug-in modules.
- The power connection should always be disconnected prior to insertion or removal of a PSU from the enclosure.
- Do not attempt to disassemble the rear sub-chassis from the enclosure.
- Provide a suitable power source with electrical overload protection to meet the requirements laid down in the technical specification.



Caution: Operating temperatures inside the enclosure drawers can reach up to 60°C. Take care when opening drawers and removing drive carriers.

- If any component of the product fails, consult Lenovo Support.
- Do not remove cooling modules, PSUs or ESM unless you have a replacement model of the correct type ready for insertion.
- For North American use, each branch circuit must be rated for 20A.
- The equipment is suitable for connection to an IT power system (Norway), when mounted in a Restricted Access Location where equipotential bonding has been applied by a service person.



Caution: Double pole/neutral fusing in PSUs.

Important: The optional RJ45 socket on the ESM is for Ethernet connection only and must not be connected to a telecommunications/open network.



Caution: Due to product acoustics it is recommended that users wear ear protection for any prolonged exposure.



Caution: To prevent over-turning, drawer interlocks stop users from opening both drawers at the same time. Do not attempt to force open a drawer when the other drawer is already open.

Rack system precautions

The enclosure must be mounted in a rack; the following safety requirements must be considered when doing so:

- The rack construction must be capable of supporting the total weight of the installed enclosure(s) and the design should incorporate stabilizing features suitable to prevent the rack tipping or being pushed over during installation or in normal use.
- When loading a rack with enclosures, fill from the bottom up; empty from the top down.
- To avoid danger of the rack toppling over, do not slide more than one enclosure out of the rack at a time.
- The system must be operated with low pressure rear exhaust installation [back pressure created by rack doors and obstacles not to exceed 5 Pascals (0.5mm water gauge)].
- The rack design should take into consideration the maximum operating ambient temperature for the unit, which is 35°C.
- The rack should have a safe electrical distribution system. It must provide over-current protection for the unit and must not be overloaded by the total number of units installed in the rack. When addressing these concerns consideration should be given to the electrical power consumption rating shown on the nameplate.
- The electrical distribution system must provide a reliable ground for each unit in the rack.
- The design of the electrical distribution system must take into consideration the total ground leakage current from all the PSUs in all the units. The rack may require labeling with "HIGH LEAKAGE CURRENT. Ground connection essential before connecting supply".

ESD precautions

It is recommended that you fit and check a suitable anti-static wrist or ankle strap and observe all conventional ESD precautions when handling plugin modules and components. Avoid contact with backplane components and module connectors, etc.

Product rating

The product ratings are: voltage: 200 to 240 VAC; current: 16A or 13A per inlet; frequency: 50 to 60 Hz. This information can also be found on the back of the PSUs.

Preparation

Before you begin

Before you begin, make sure the site where you intend to set up and use your storage system has the following:

- Standard power from an independent source or a rack power distribution unit with a UPS.
- Host computer with the correct firmware, BIOS and drivers. Contact your supplier for the correct software levels.

Before setting up your enclosure ensure you have the following:

- SAS HBA
- MiniSAS HD to MiniSAS HD cable or MiniSAS HD to MiniSAS cable
- Power cord
- Rack kit

Contact Lenovo Support for a list of qualified accessories for use with the enclosure. The

Accessory Box contains the power cords and other ordered accessories.

Unpacking the storage system



Caution: There are three straps tight on the system delivery as shown in Figure 1. Each strap can weigh up to 55 kg. Hold the straps evenly and lift the system out of the box with four persons.

1. Position the shipping case within 2m (6 feet) of the site where you intend to use your storage system.
2. Inspect the packaging for crushes, cuts, water damage or any other evidence of mishandling during transit. If there is any damage, photograph the packaging for future reference before opening.

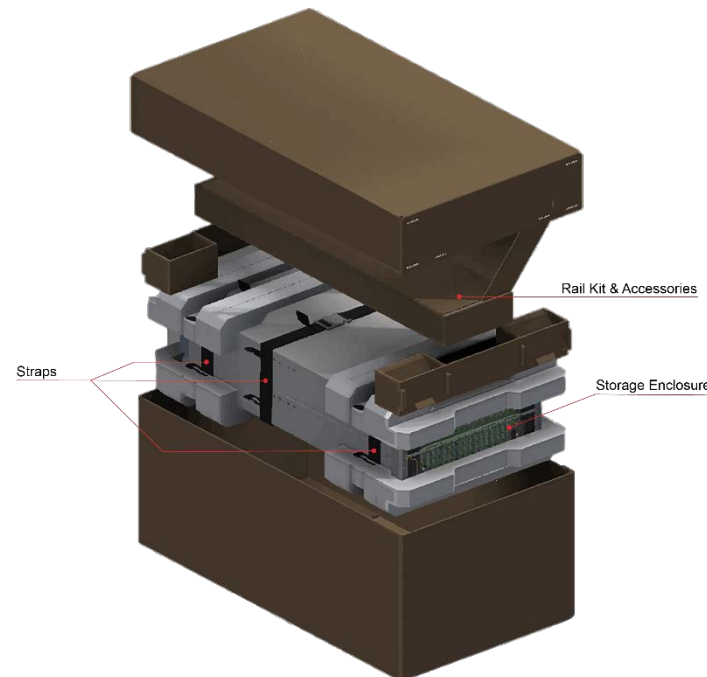

Figure 1: Unpacking the storage system

Installation

Mounting the system into a rack



Warning: Ensure that you have fitted and checked a suitable anti-static wrist or ankle strap and observe all conventional ESD precautions when handling modules and components. Avoid contact with backplane components and module connectors, etc. ESD damage is not covered by warranty.

Rail Kit Adjustment Range: inside of the front post to inside of the rear post: 713mm - 884mm. Suits a 1 metre deep rack within Rack Specification IEC 60297.

Note: A Torx T20 screwdriver is needed to lock and unlock the drawers.

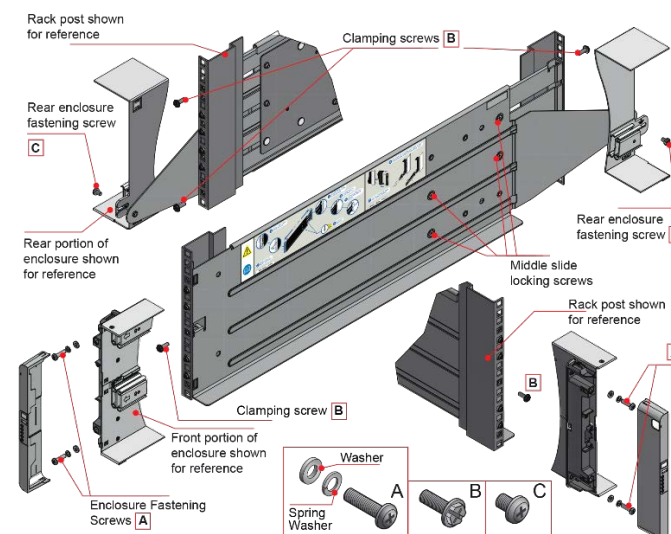

Figure 2: Mounting the system into a rack (left hand rail only shown for clarity)



Caution: A populated enclosure can weigh up to 135kg (298lb). Do not try to lift it by yourself.

- Note:** The rail location pins are pre-assembled to suit square and round hole racks only.
1. Ensure the pre-assembled rail is at its shortest length.
 2. Locate the rail location pins inside the front of the rack and extend the length of the rail assembly to enable the rear location pins to locate. Ensure the pins are fully located in the square or round holes in the rack posts (see Figure 2).
 3. Fully tighten all clamping screws (left and right).
 4. Slide the enclosure fully home on its rails.
 5. Fasten the front of the enclosure using the enclosure fastening screws and washers (x4) as shown in Figure 2.

6. Fix the rear of the enclosure to the hold down bracket with the rear enclosure fixing screws (x2), fitted from inside the enclosure.

Enclosure layout

For the drive number, refer to the label on the drawer.

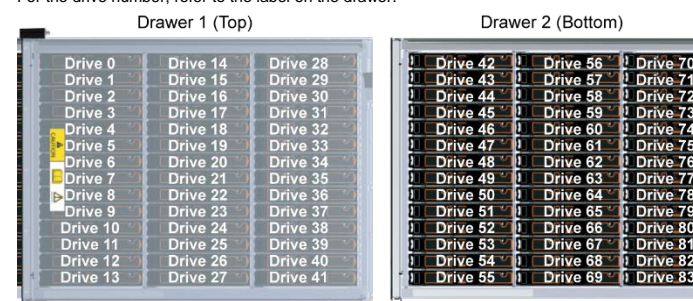

Figure 3: Drive numbering

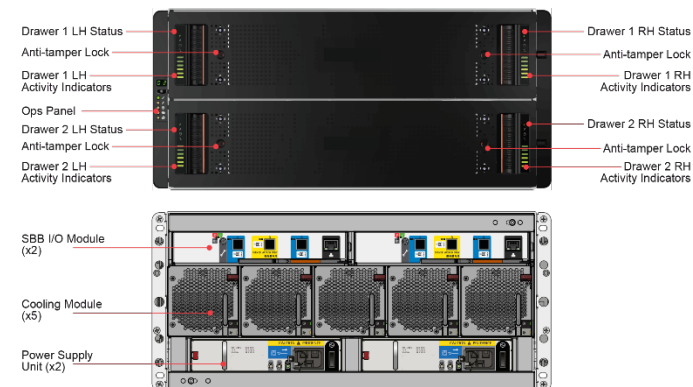

Figure 4: Module locations

Connecting to a host: examples

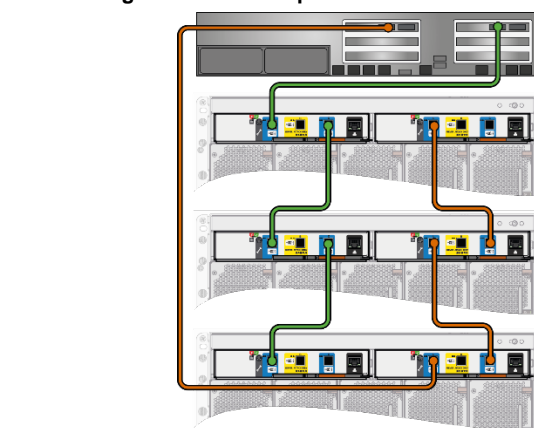

Figure 5: Single host - multiple enclosures

To remove a DDIC:

1. Slide the release button and the DDIC will pop up slightly from the slot. Slide the release button, as shown in Figure 6-1.
2. Slide the top surface in the direction of the arrow until the latch releases, as shown in Figure 6-1.

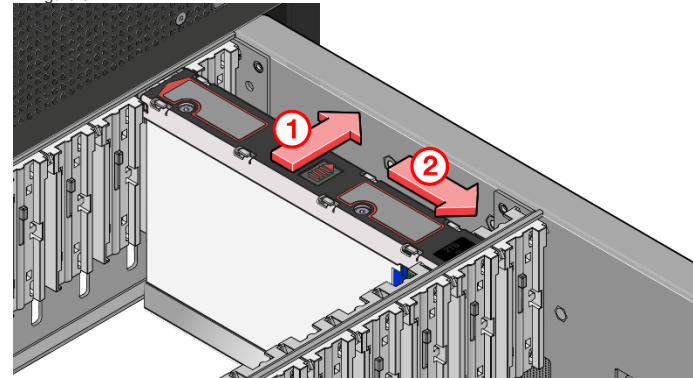

Figure 6-1: Sliding the DDIC release button and latch

3. If the DDIC does not pop up, perform steps 1 and 2 simultaneously. The DDIC will pop up slightly from the slot.
4. Lift the DDIC out of the slot, as shown in Figure 6-2.

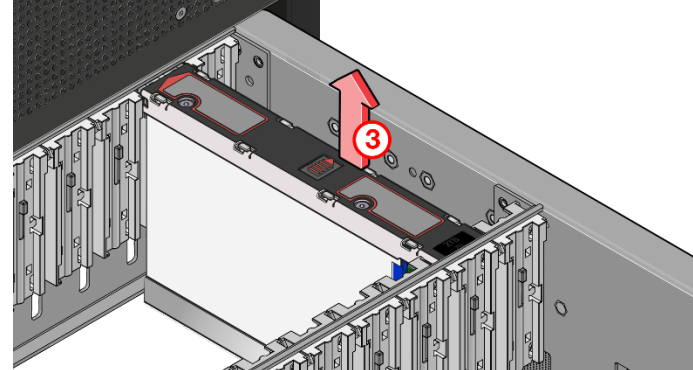

Figure 6-2: Removing the DDIC

To install a DDIC:

1. Insert the DDIC carrier into the slot, and then push it down until it stops.
2. Slide the top latch in the direction of the arrow until the latch clicks into place (see Figure 6).

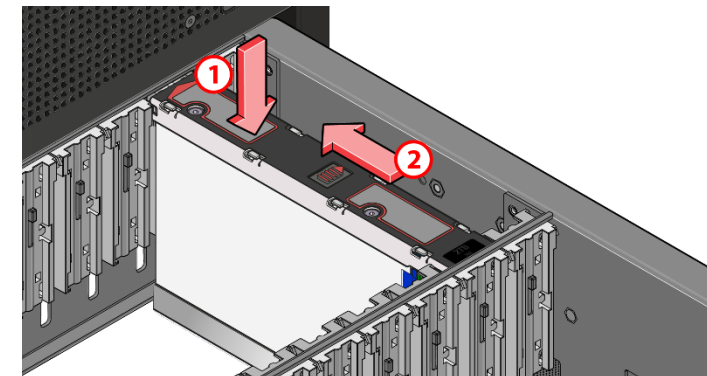

Figure 7: Installing a DDIC

Installing and removing cooling modules, PSUs, and ESM



Caution: Handle the modules carefully and avoid damaging the connector pins. Do not install if any pins appear to be bent.



Warning: Do not remove these modules unless a replacement can be immediately added. The system must not be run without all modules in place.

To remove a cooling module:

Depress the retaining latch and pull the cooling module handle (see figures 8 & 9).

To install a cooling module:

Installation is the reverse process. Ensure the retaining latch clicks into place.

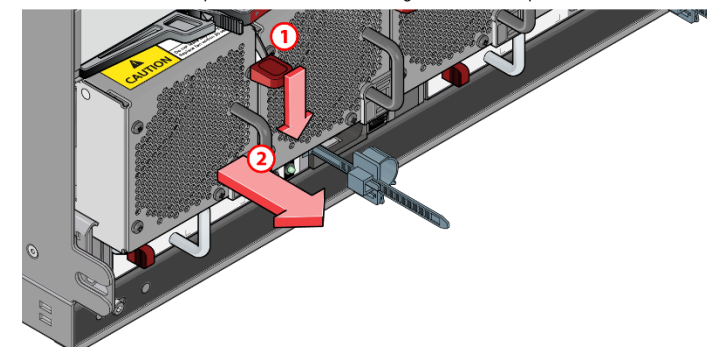

Figure 8: Removing a Cooling Module (1)

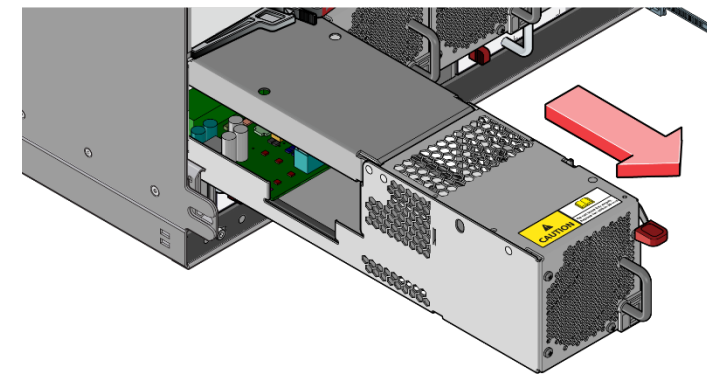

Figure 9: Removing a Cooling Module (2)



Warning: Do not remove covers from the PSU. Danger of electric shock inside. Return the PSU to your supplier for repair.



Warning: Ensure blanking modules are installed in open bays before operation.

To remove a power supply unit:

Squeeze the retaining latch and pull the power supply unit handle (See figures 10 and 11).

To install a power supply unit:

Installation is the reverse process. Ensure the retaining latch clicks into place.

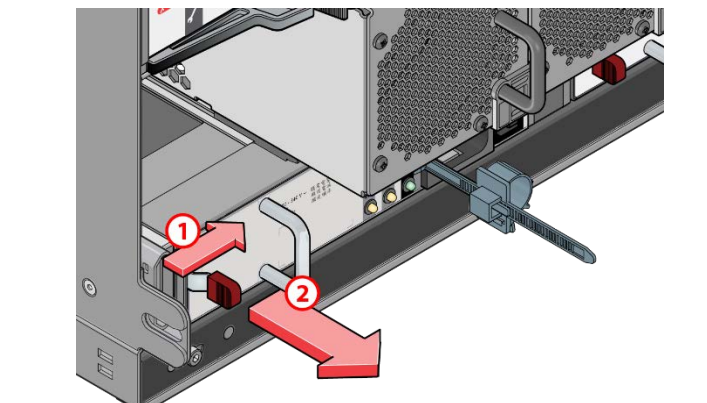

Figure 10: Removing a Power Supply Unit (1)



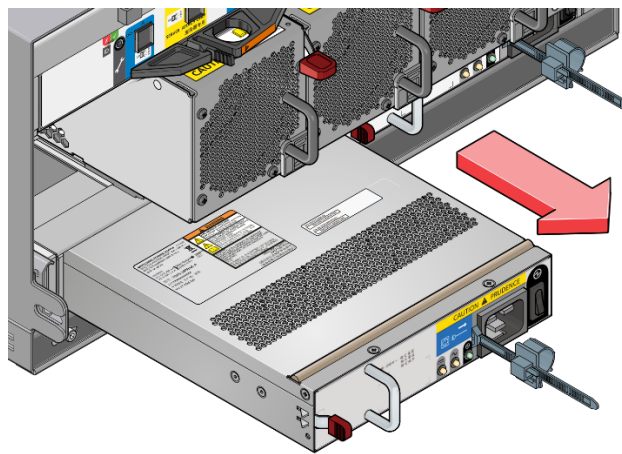

Figure 11: Removing a Power Supply Unit (2)

To remove an ESM:

1. Grasp the module latch between the thumb and forefinger and squeeze them together to release the latch.
2. Pull the latch outward to cam the module out of the enclosure (Figure 12).
3. Grip the latch handles and withdraw the module (Figure 13).
4. Only one ESM shall be fitted when one PSU is installed.

To install an ESM:

1. With the latches in the open position, slide the module into the enclosure until the latches engage automatically.
2. Move the cam lever to the locked position to ensure the module is fully inserted.
3. A click should be heard as the latches engage.

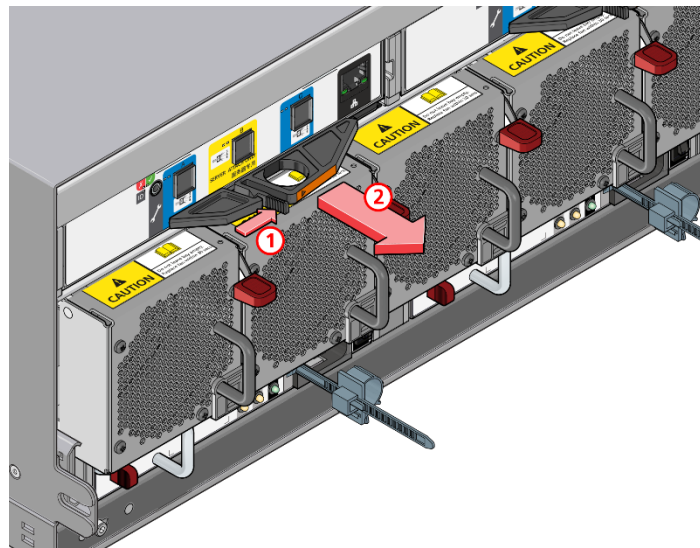

Figure 12: Removing an ESM (1)

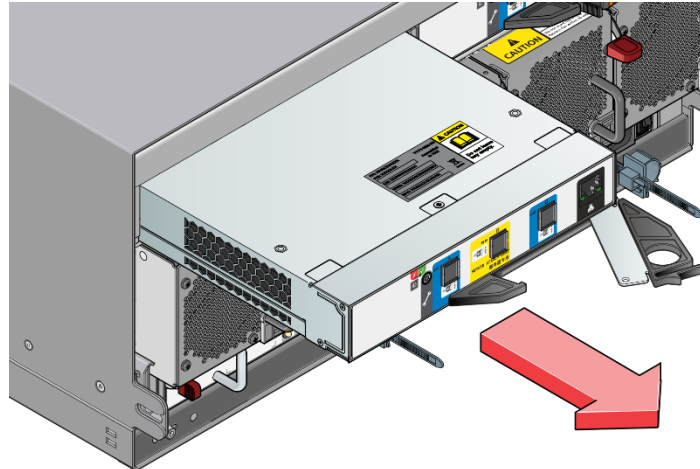

Figure 13: Removing an ESM (2)

LED states

ESM LEDs

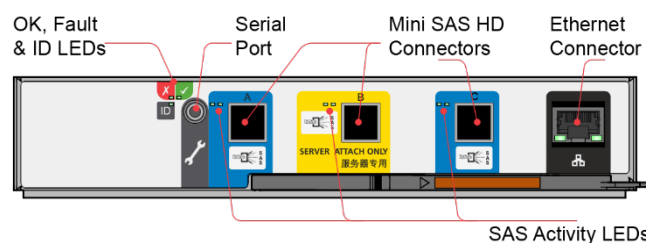

Figure 14: 12G ESM LEDs

| LED | Description |
|-------------------|--------------------------------------------------------------------------------------------------------------------------------------------------------------------------------------------------------------------|
| ID LED | Blue when the module is being identified. |
| Fault LED | Amber when there is a fault in the controller. |
| OK LED | Green when the controller is operating correctly. Flashing green when there is a controller VPD error. |
| SAS Activity LEDs | Steady green: connection on one or more links but no activity. Flashing green: connection and activity. Steady amber critical fault. Flashing amber: non critical fault (e.g. not all links up established). |

Ops panel LEDs

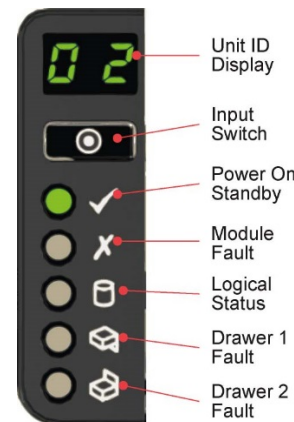

Figure 15: Ops panel LEDs

| Unit ID Display | Power (Green/Amber) | Module Fault (Amber) | Logical Status (Amber) | Drawer 1 Fault | Drawer 2 Fault | Associated LEDs or Alarms | Status |
|-----------------|---------------------|----------------------|------------------------|----------------|----------------|----------------------------------|------------------------------------------------------------------------------------------------------------------------|
| X | On | Off | Off | Off | Off | | Aux present, overall power failed or off. |
| X | On | On | X | X | X | Single beep, then double | Ops Panel power on (5s) test state. |
| X | On | Off | Off | Off | Off | | Power on, all functions good. |
| X | On | On | X | Off | Off | PSU fault LEDs, fan fault LEDs | Any PSU fault, fan fault, over or under temperature. |
| X | On | On | X | Off | Off | SBB module LEDs | Any SBB module fault |
| X | On | Flashing | X | Off | Off | | Enclosure logical fault (eg VPD config. error). |
| X | On | Flashing | X | Off | Off | Module status LED on SBB module | Unknown (invalid or mixed) SBB module type installed, I2C Bus failure (inter SBB comms), EBOD VPD configuration error. |
| X | On | Flashing | X | Off | Off | PSU fault LEDs, fan fault LEDs | Unknown (invalid or mixed) PSU module type installed, or I2C Bus failure (PSU comms). |
| X | On | On | X | Off | Off | DDIC fault LED, drawer fault LED | Drive failure has occurred causing loss of availability or redundancy |
| X | On | X | Flashing | Off | Off | Arrays in impacted state | Arrays operating background function |
| X | On | Flashing | Flashing | Off | Off | S1 | Unit ID number different from "Start Of Day" |
| X | On | X | X | On | Off | Fault LED on Drawer 1 | Fault present on drawer 1 (drive, cable or fanout card fault) |
| X | On | X | X | Off | On | Fault LED on Drawer 2 | Fault present on drawer 2 (drive, cable or fanout card fault) |
| Flashing | X | X | X | X | X | | SES Controlled enclosure identify |

X = Disregard

Drawer indicators

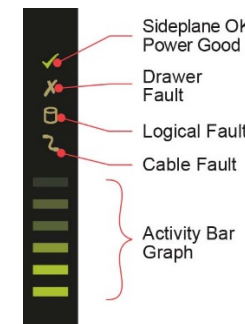

Figure 16: Drawer status indicators

| Sideplane OK/Power (Green) | Sideplane Fault (Amber) | Logical Fault (Amber) | Cable Fault (Amber) | Activity Bar Graph (Green) | Status |
|----------------------------|-------------------------|-----------------------|---------------------|----------------------------|-----------------------------------------------------------------------|
| On | Off | Off | Off | X | Sideplane card OK/Power good |
| Off | On | X | X | Off | Sideplane card fault |
| On | On | X | X | X | Drive failure has occurred causing loss of availability or redundancy |
| On | X | On | X | X | Drive fault (Host indicated) |
| On | X | Flashing | X | X | Arrays in impacted state |
| Off | X | X | On | Off | Cable fault |
| On | Off | Off | Off | On* | Drive activity |

* The Activity Bar Graph is a 6-segment drive activity meter, showing activity of the SAS interface to the sideplane. For zero activity, no segments are lit, scaling linearly until all segments are lit when the interface is transferring data at full capacity.

X = Disregard

PSU LEDs

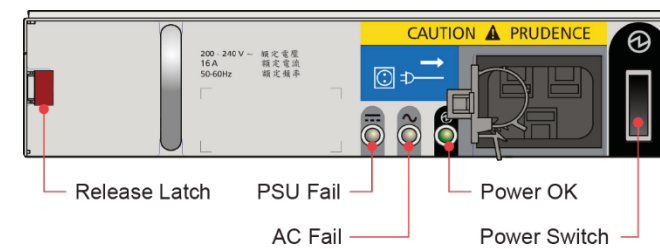

Figure 17: PSU LEDs

| PSU Fail (Amber) | AC Fail (Amber) | Power OK (Green) | Status |
|------------------|-----------------|------------------|-----------------------------------------------------------------------------------|
| Off | Off | Off | No AC power to either PSU. |
| On | On | Off | PSU present but not supplying power. |
| Off | Off | On | Mains AC present, switch on. This PSU is providing power output. |
| Off | Off | Flashing | AC power present, PSU in Standby mode (i.e. other PSU is providing power output). |
| Flashing | Flashing | Off | PSU firmware download. |
| On | On | Off | PSU Alert State (usually due to reaching critical temp). |
| Off | On | Off | Mains AC to this PSU is missing (this PSU is now standby, other PSU is OK). |
| On | On | On | GEM software lost communication with PSU. |
| On | X | Off | PSU has failed. |

X = Disregard

Cooling module LEDs

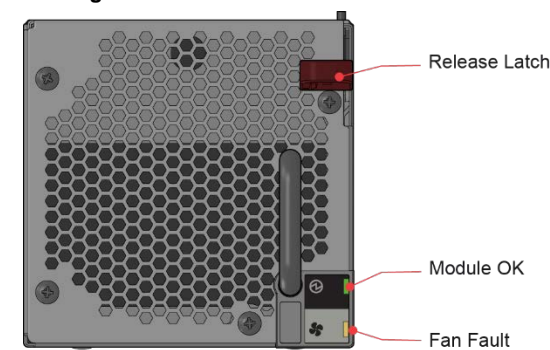

Figure 18: Cooling module LEDs

| Module OK (Green) | Fan Fault (Amber) | Status |
|-------------------|-------------------|-----------------------------------------------|
| X | Off | Fan OK |
| X | On | Communication lost with fan module controller |
| X | On | Reported fan speed is out of tolerance |
| On | X | Module good (battery and fan) |

X = Disregard

Legal notices

Lenovo and the Lenovo logo are trademarks of Lenovo in the United States, other countries, or both.
Other company, product, or service names may be trademarks or service marks of others.