

# Storage Configurator

Lenovo ThinkStation P3 Tower, P3 Ultra, and P3 Tiny



# Table of Contents

Overview.....	3
Section 1 – Installing NVMe Devices in P3 Tower.....	4
Section 2 – Installing NVMe Devices in P3 Ultra.....	9
Section 3 – Installing NVMe Devices in P3 Tiny.....	14
Section 4 – Installing SATA Drives in P3 Tower.....	17
Section 5 – Installing SATA Drives in P3 Ultra.....	22
Section 6 – RAID Levels.....	26
Section 7 – Configuring RAID.....	28
Section 8 – Document Revision History.....	38



## Overview

The purpose of this document is to provide guidelines for users on how to optimally configure the system storage in the ThinkStation P3 series platform to ensure proper functionality.

Below is a table showing the drive type support of each system in the P3 series:

*Table 1 - P3 Series Storage Support*

System	M.2 NVMe	SATA	Notes
<b>P3 Tower</b>	Supported, Max QTY: 3*	Supported, Max QTY: 4*	3.5" SATA or 2.5" SATA w/ adapter
<b>P3 Ultra</b>	Supported, Max QTY: 2	Supported, Max QTY: 1	2.5" SATA only
<b>P3 Tiny</b>	Supported, Max QTY: 2	Not Supported	

\*Max quantity varies by configuration. See [Section 1](#) & [Section 4](#) for more information.

The following sections give detailed instructions on the installation of M.2 NVMe and SATA drives, as well as provide part numbers for required components needed for proper installation.

P3 Tower, P3 Ultra, and P3 Tiny support RAID levels 0 & 1 for onboard NVMe drives. P3 Tower can support levels 0, 1, 5, & 10 for SATA drives, depending on system configuration. RAID configurations and setup instructions are discussed in [Section 6](#) and [Section 7](#).

# Section 1 – Installing NVMe Devices in P3 Tower

M.2 NVMe devices can be installed into the following locations on the ThinkStation P3 Tower motherboard shown below. The M.2 NVMe drives may use the dedicated PCIe Gen 4 capable onboard M.2 slots or use a Gen 3 PCIe M.2 Add-In Card (AIC) in PCIe Slot 3. P3 Tower supports up to two double-sided 4TB M.2 2280 drives in the onboard slots and up to one single-sided 2TB M.2 2280 in the AIC. The P3 chassis also has the ability to mount M.2 22110 and M.2 2242 drives, however at the time of this writing, all Lenovo supported M.2 drives for P3 Tower are 2280.

Figure 1 - P3 Tower Motherboard Diagram with NVMe Callouts

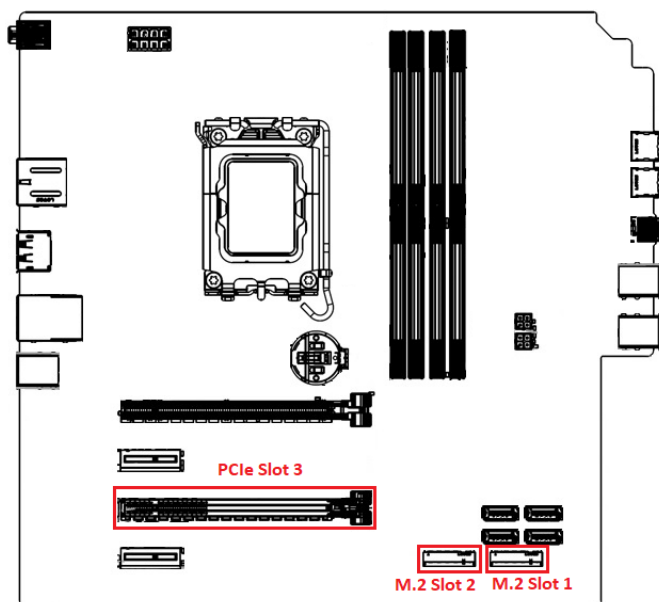
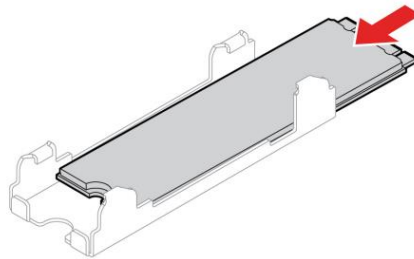

Figure 2 - P3 Tower Chassis with NVMe Callouts



**For M.2 NVMe drives in the onboard M.2 slots:**

1. Remove the film that covers the thermal pad on the bracket, if any. Then, install the M.2 solid-state drive by sliding the drive in the bracket.



2. Remove the film that covers the thermal pad at the bottom of the heat sink, if any. Then, install the heat sink onto the M.2 drive in the bracket.

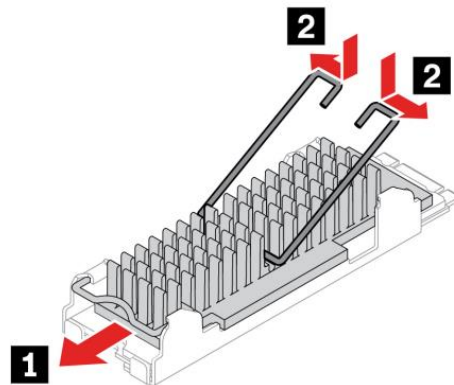

3. If not already present, install the M.2 drive bracket into the system.

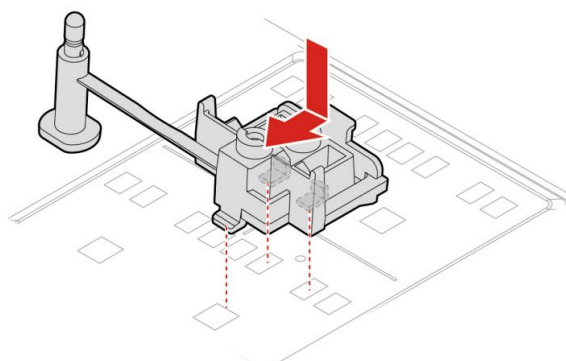

4. Install the heat sink with the bracket into the system.

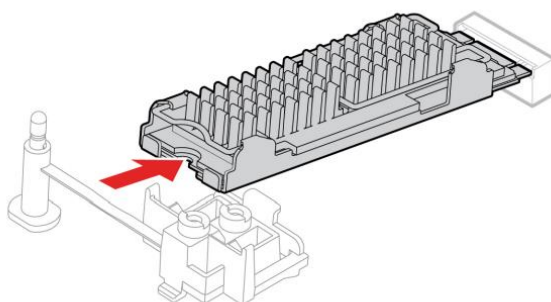

5. Insert the stopper.

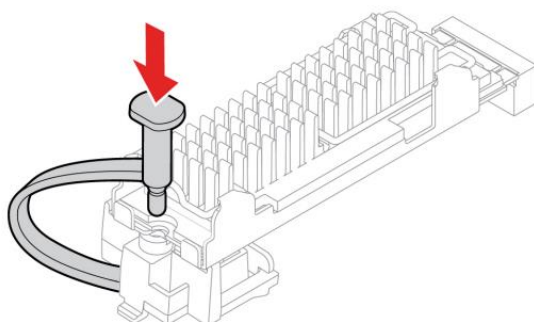

**Note:** P3 Tower systems come equipped with only the necessary onboard M.2 parts required for the configuration when it was originally ordered from Lenovo. Adding an M.2 drive to an open onboard slot requires the option kit [4XF1C39743](#), which includes the heatsink assembly and bracket with stopper seen in the instructions above. For supported double-sided 4TB M.2 drives, FRU 5F10U94103 is needed instead.

**For M.2 NVMe drives installed in the PCIe Add-in Card (AIC):**

1. Ensure that a thermal pad is placed in position on the M.2 solid-state drive PCIe adapter.

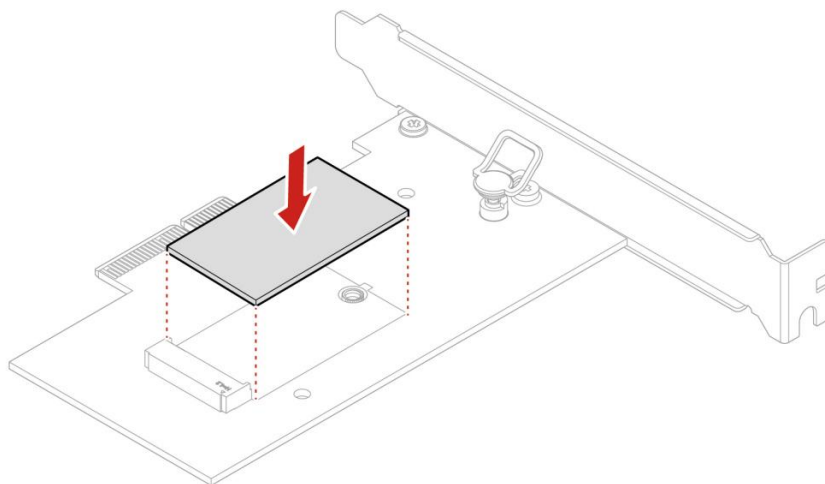

2. Insert the new M.2 solid-state drive into the M.2 slot. Then, insert the stopper into the hole to secure the new drive.

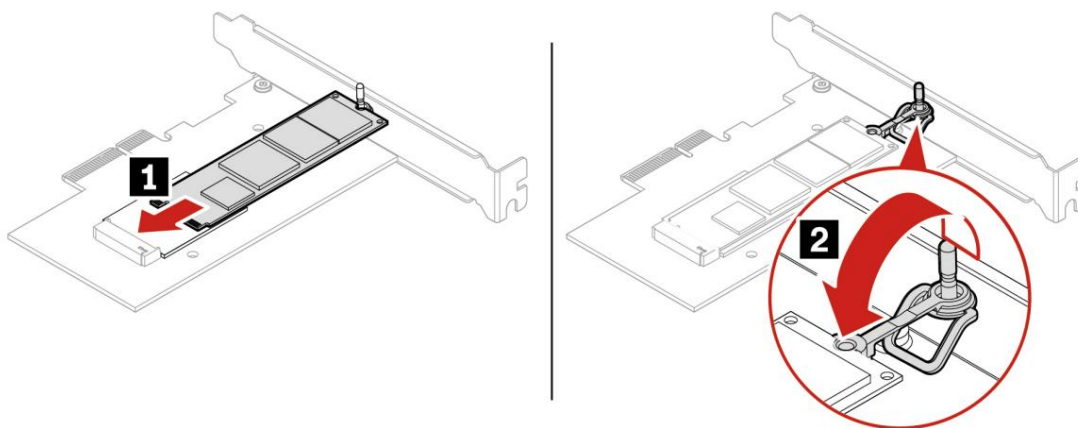

3. Position the heat sink on the M.2 solid-state drive PCIe adapter. Ensure that the two mounting studs in the heat sink are aligned with the holes in the M.2 solid-state drive PCIe adapter. Then, push the mounting studs downward to secure the heat sink to the adapter.

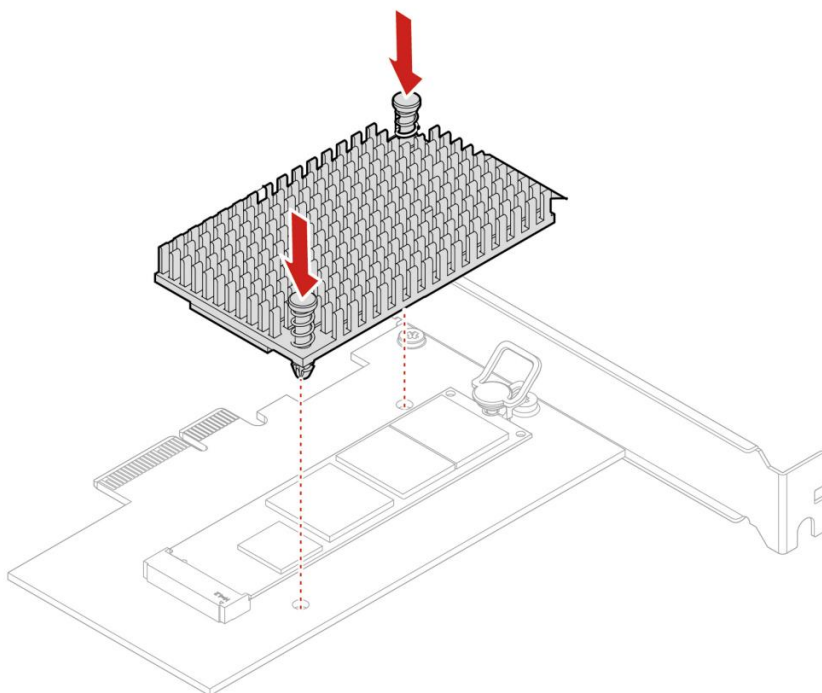

**Note:** The M.2 NVMe Add-in Card's option part number is 4XH0L08578. This kit will include the add-in card, thermal pad, and heatsink.



## Section 2 – Installing NVMe Devices in P3 Ultra

M.2 NVMe devices can be installed into the following locations on the ThinkStation P3 Ultra motherboard shown below. Both onboard M.2 NVMe slots are PCIe Gen 4 capable and can each support up to a double-sided 4TB M.2 2280 drives. When opening the chassis, the NVMe slots are on the side of the motherboard opposite the CPU, beneath their own dedicated heatsink. The steps to access the M.2 slots are outlined in this section.

Figure 3 - P3 Ultra Motherboard Diagram with NVMe Callouts

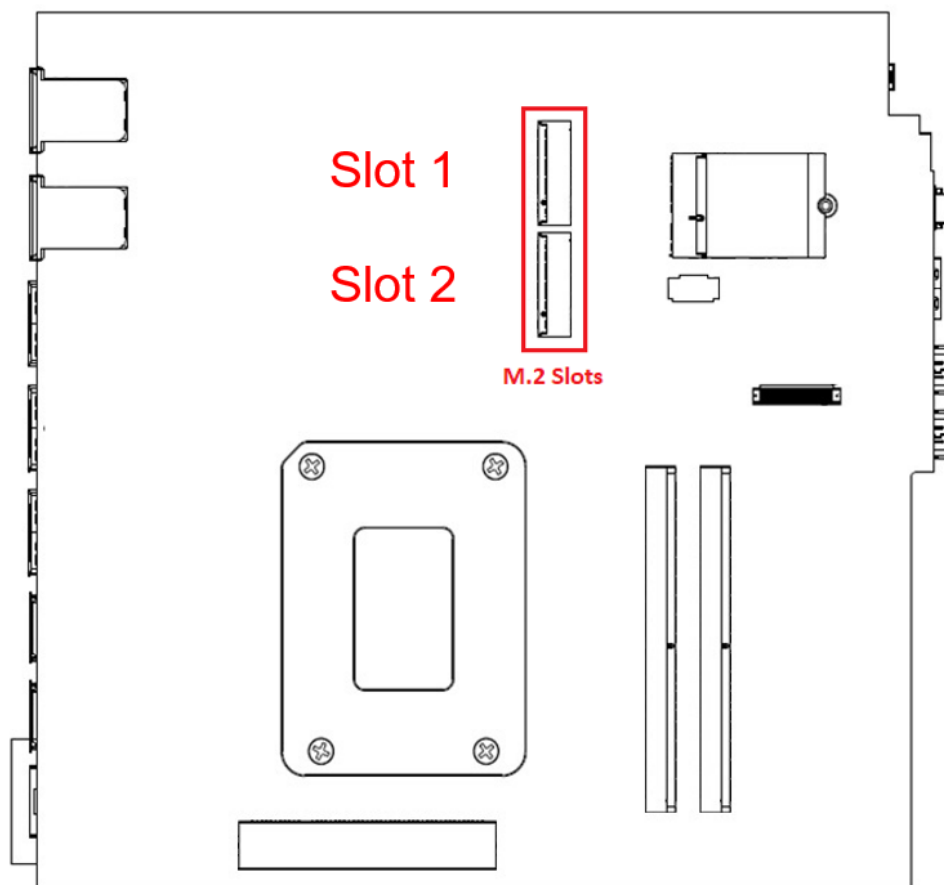
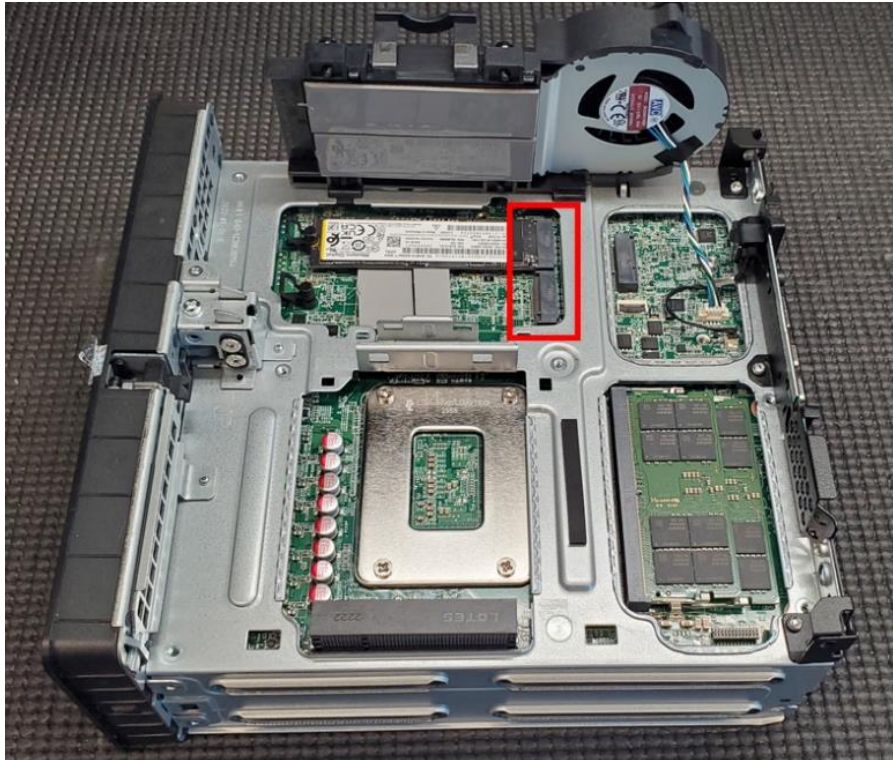
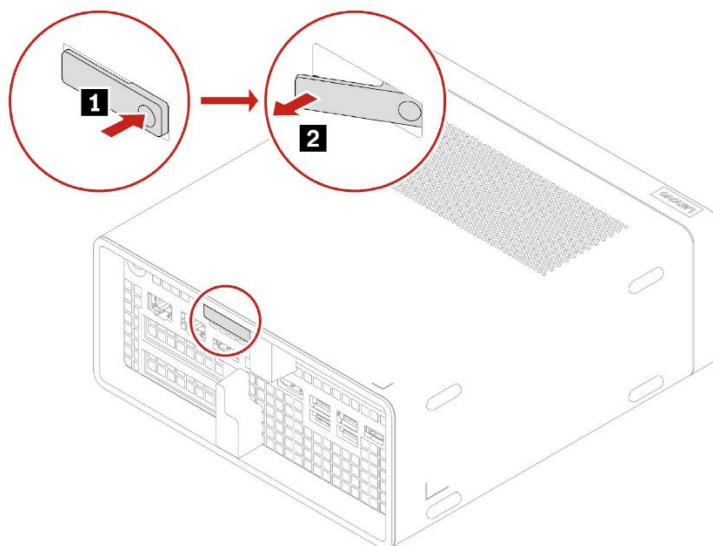

Figure 4 - P3 Ultra chassis with NVMe Callout



### **Access the onboard M.2 NVMe slots:**

1. Power down the system. Remove the power cable and all attached devices and cables from the system. Locate the chassis opening lever on the back of the system. Push in one side of the lever and pull on the extended lever.



2. While pulling on the lever, hold the chassis body in place until the motherboard assembly slides out of the chassis shell.

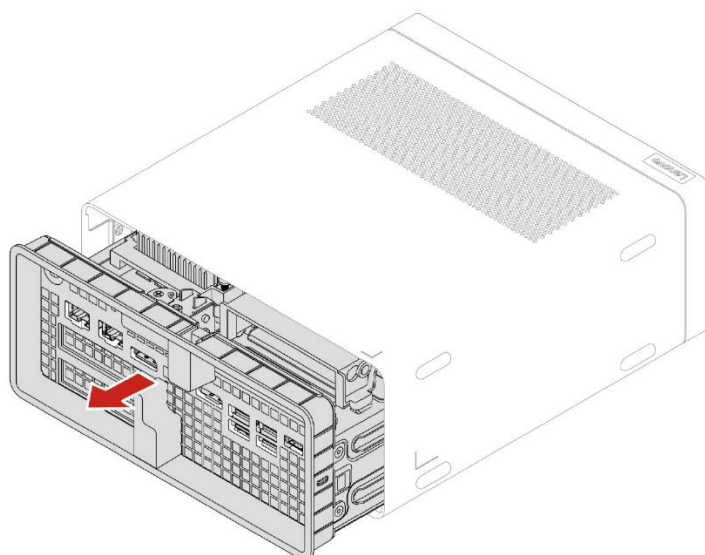

3. The M.2 NVMe heat sink is now accessible as seen in the image below. To remove the heat sink, squeeze the locking handle and pull up on the heat sink.

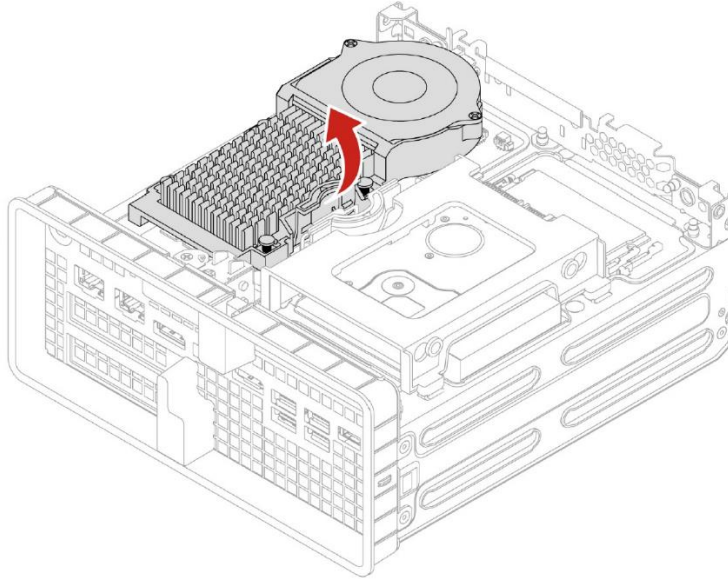

**Remove and install the onboard M.2 NVMe drives:**

1. To remove a drive, pull up on the retaining plunger for the M.2. It may be necessary to gently pull up on the drive to free it from the heat sink pad underneath. When the drive is free, pull it sideways away from the slot as seen below.

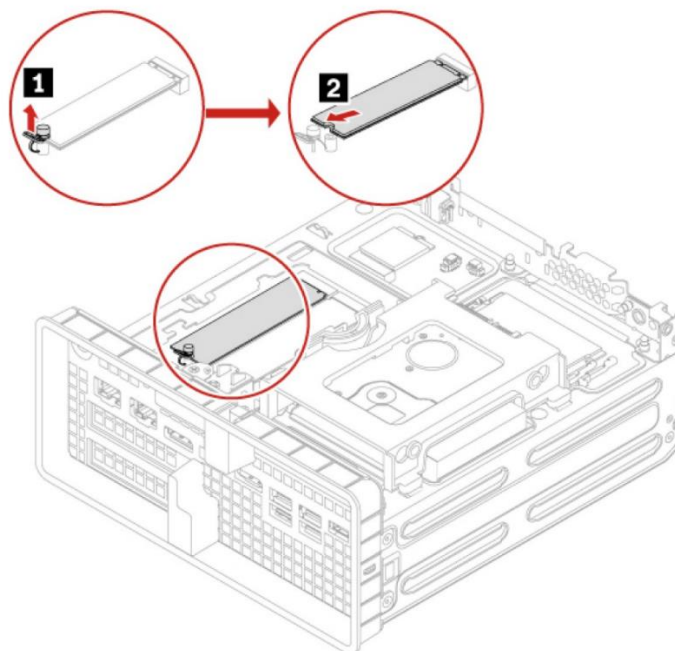

2. Reverse the steps to install a drive. For best drive performance when only one M.2 drive is installed in the system, install in Slot 1 as seen in the image below:

*Figure 5 - P3 Ultra M.2 Slot Reference Picture*

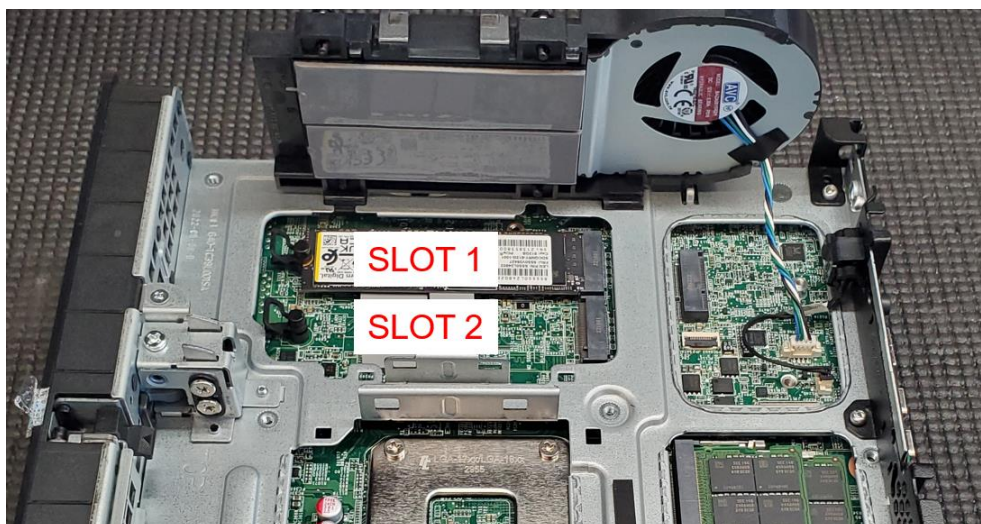

---

## Section 3 – Installing NVMe Devices in P3 Tiny

There are only two Gen 4 M.2 slots in the P3 Tiny. No other drives can be added to the system. The steps to access to these M.2 slots is explained in this section. P3 Tiny supports up to a single-sided 2TB M.2 2280 drive in each of the onboard slots.

### Accessing the M.2 drives:

1. Disconnect the power and all connected devices.
2. Remove the rear screw, (1) in the image.
3. Slide the cover forward and lift to remove it (2).

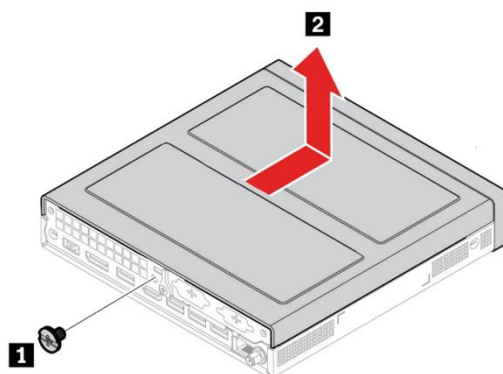

4. Turn the system over and slide the bottom plate towards the front of the system.

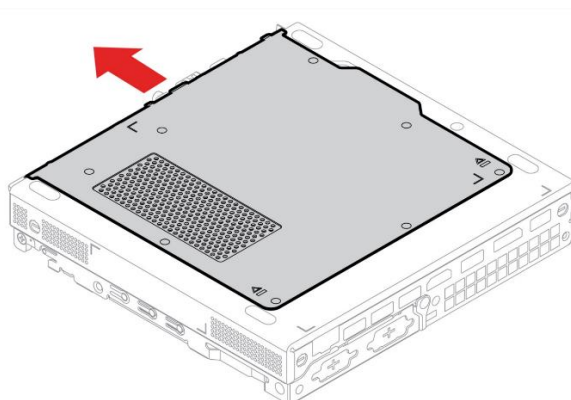



## **Removal and installation of the M.2 drives:**

1. Locate the M.2 drive(s) and remove the retention latch(es).

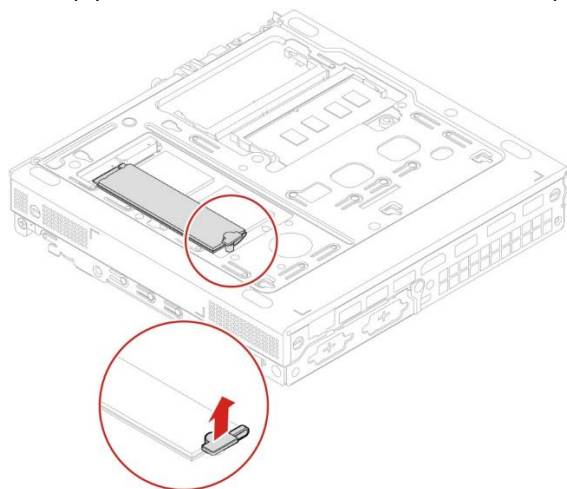

2. With the retention latch removed the M.2 SSD should lift slightly. If it remains attached to the heat sink pad underneath it, pull up on it gently until it is free of the pad. Slowly slide the M.2 horizontally away from the M.2 slot. To install the M.2 drive(s), reverse the procedure.

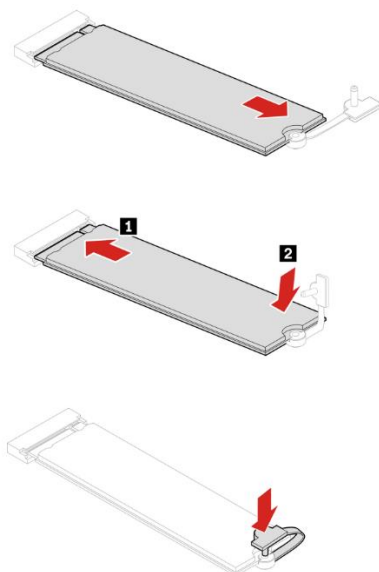

3. For best drive performance when only one M.2 drive is installed in the system, install in Slot 1 as seen in the image below:

Figure 6 - P3 Tiny M.2 Slot Numbers

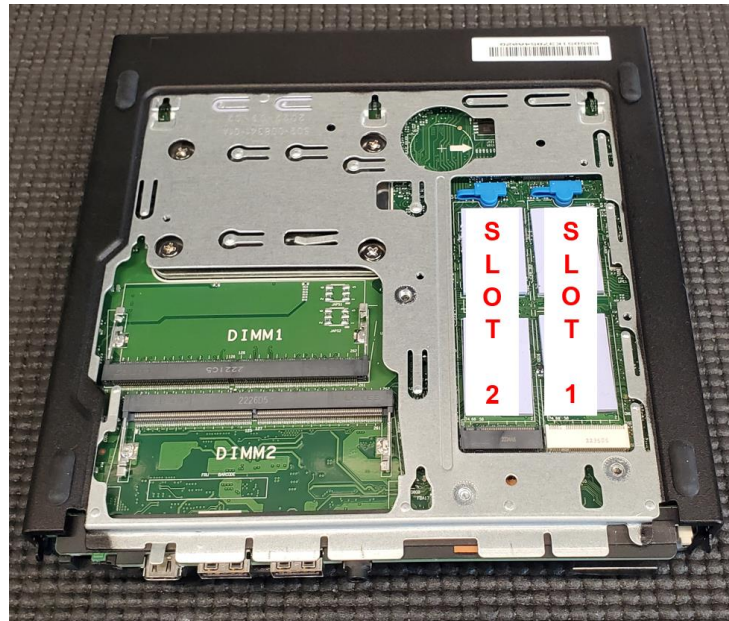

4. Reverse steps 1-4 of “Accessing the M.2 drives” to reassemble the system.



## Section 4 – Installing SATA Drives in P3 Tower

The ThinkStation P3 Tower can hold a maximum of four SATA drives. The P3 Tower motherboard has four SATA port connections, labelled SATA1, SATA2, SATA3, and SATA4 (eSATA) in the order they show up in the system BIOS.

Figure 7 - P3 Tower Motherboard with SATA Callouts

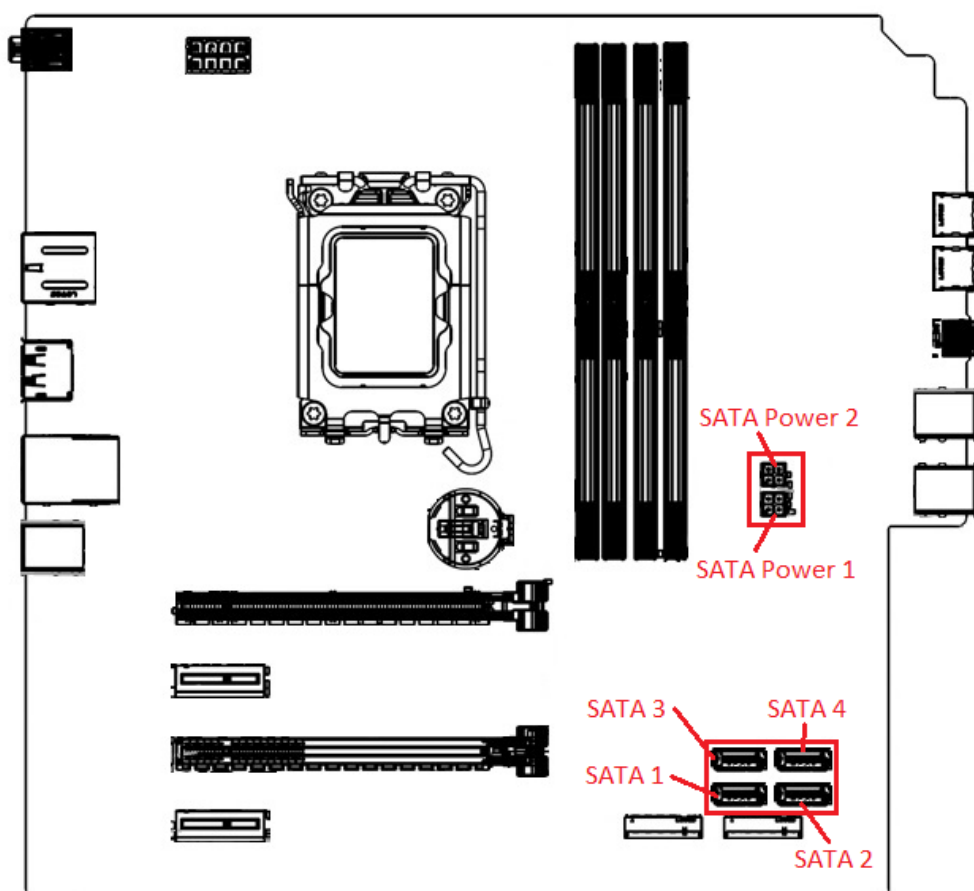

**Note:** The ability to maximize the number of SATA drives is dependent upon using a “3rd HDD enclosure” or “Front-Access Storage Enclosure” (FASE), depending on CPU SKU and fan cooler (See *Table 2 & Figures 8 & 9*).

SATA port 4 is an eSATA port. This port is capable of hot-swapping SATA drives after the feature is enabled in BIOS, found under Devices→Storage Setup→”SATA Drive 4 Hot-Plug Support”→Enable/Disable.

Due to the external accessibility of the FASE, Lenovo recommends only using the hot-swap feature with the FASE bay. Lenovo strongly recommends against accessing internal drives/components while the system is operating.

Table 2 - P3 Tower CPU Cooler & HDD Enclosure Compatibility

CPU Cooler	CPU	HDD Enclosure Capability
<b>125W Cooler</b>	i9-13900k, i7-13700k, i5-13600k	3rd HDD Enclosure
<b>65W Cooler</b>	i9-13900, i7-13700, i5-13600, i5-13500, i5-13400, i3-13400	3rd HDD Enclosure <u>OR</u> FASE

Figure 8 - P3 Tower FASE Enclosure with 65W Cooler (Chassis beam for mounting HDD enclosure removed for visibility)

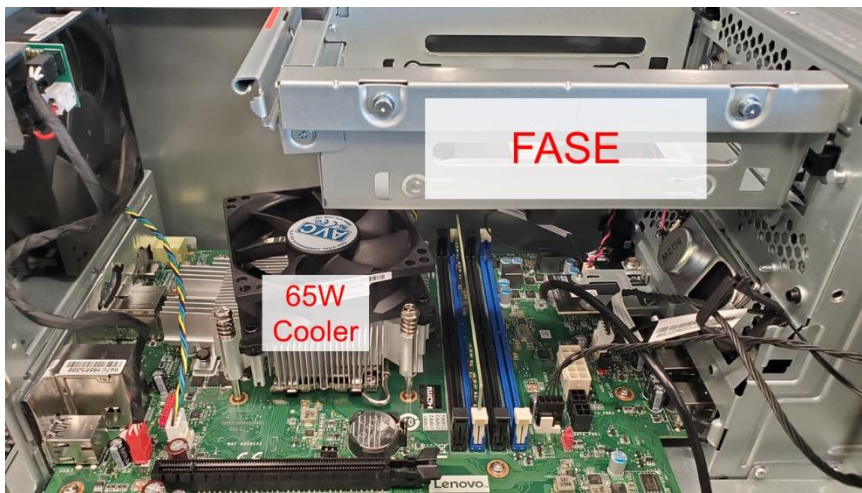
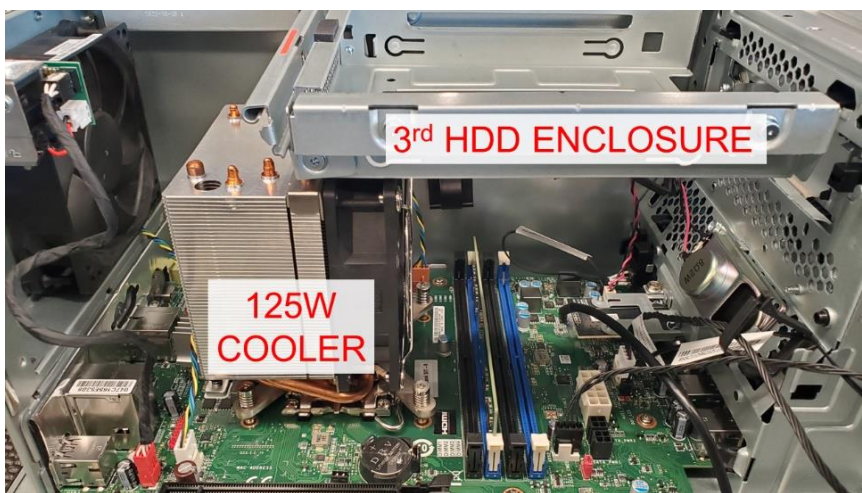
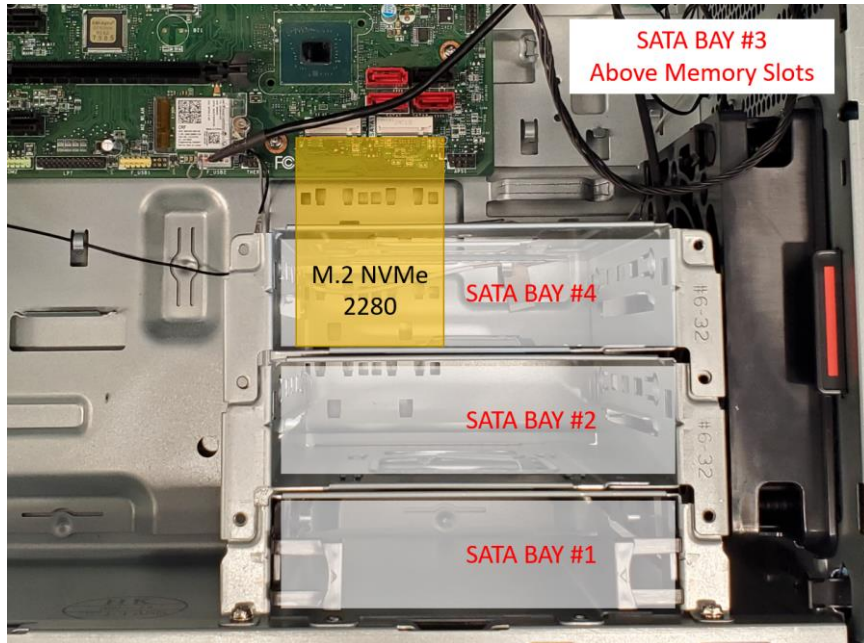

Figure 9 - P3 Tower 3rd Enclosure with 125W Cooler (Chassis beam for mounting HDD enclosure removed for visibility)



**Note:** The use of four SATA drives will utilize all the available SATA ports on the motherboard. Adding additional SATA drives to the system may impact certain lengths of M.2 drives installed in the onboard M.2 slots (See Figure 10).

Figure 10 - P3 Tower SATA Bay overlaying M.2 NVMe 2280 (Power Supply removed for visibility)



Additionally, in systems with a side fan assembly, the maximum number of SATA drives is **three** (See Figure 11) due to physical interference between the side fan assembly and SATA Bay 4.

Figure 11 - P3 Tower with Side Fan Assembly

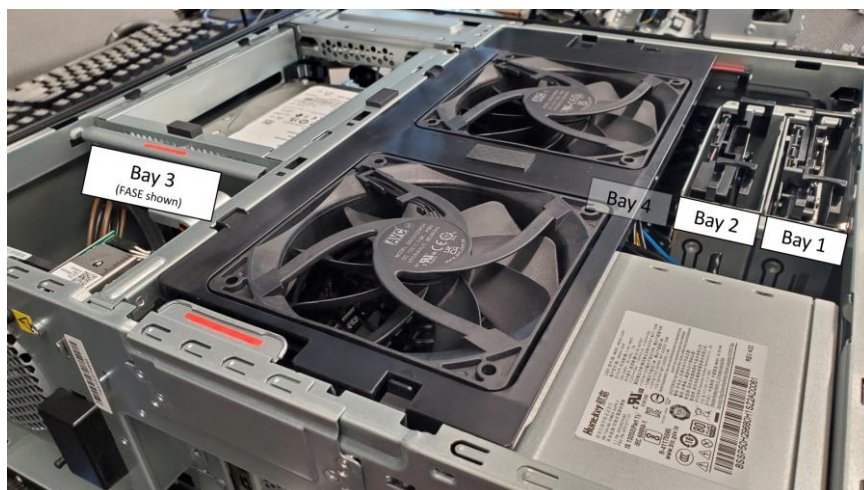



## **P3 Tower Internal Storage Drives Overview**

Below is an overview of the SATA storage locations in the P3 Tower:

*Figure 12 - P3 Tower Chassis with Numbered Callouts*

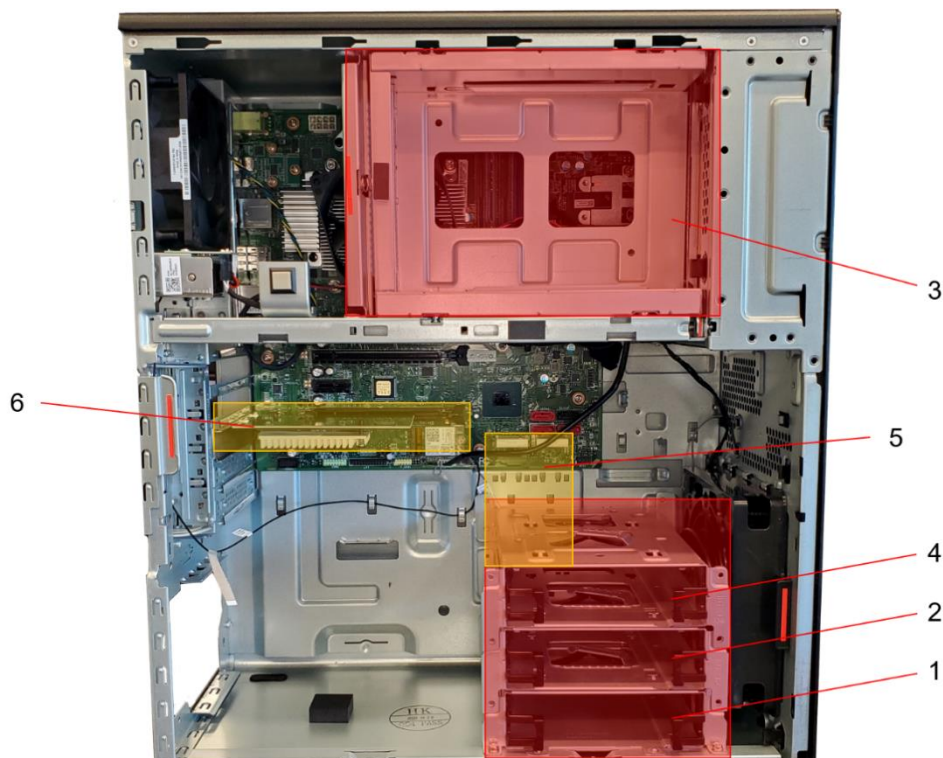

SATA Bay 1 – 3.5” primary storage drive cage

SATA Bay 2 – 3.5” storage drive cage

SATA Bay 3 – 3.5” storage drive cage OR front access storage enclosure

SATA Bay 4 – 3.5” storage drive cage (if installed, interferes with M.2 2280 drives in onboard slots)

Area 5 – Two M.2 SSD slots

Area 6 – PCIe Slot 3 for additional M.2 SSD in Add-In Card

The table below lists option kits for upgrading the P3 Tower SATA storage available at the time of this writing. Remember the previous notes in this Section in regard to adding a 4<sup>th</sup> SATA bay or FASE kit, as some option kits will not be physically compatible with certain system configurations.

*Table 3 - P3 Tower SATA Storage Options*

SATA Option Kit	Option P/N
ThinkStation Storage Kit for P3 Tower	4XF1M24243
ThinkStation Front Access Storage Enclosure for P3 Tower	4XF1M24244

## Section 5 – Installing SATA Drives in P3 Ultra

The P3 Ultra supports one 2.5" SATA drive. Adding a SATA drive into a P3 Ultra that does not already have one will require additional parts. The SATA drive will also prevent the use of PCIe x4, located on the side of the motherboard opposite the CPU. The installation requires a 2.5" Drive Bracket (FRU [5M11H28482](#)) and SATA ribbon cable (FRU [5C10U58607](#)).

Figure 13 - P3 Ultra Motherboard with SATA Port Callout

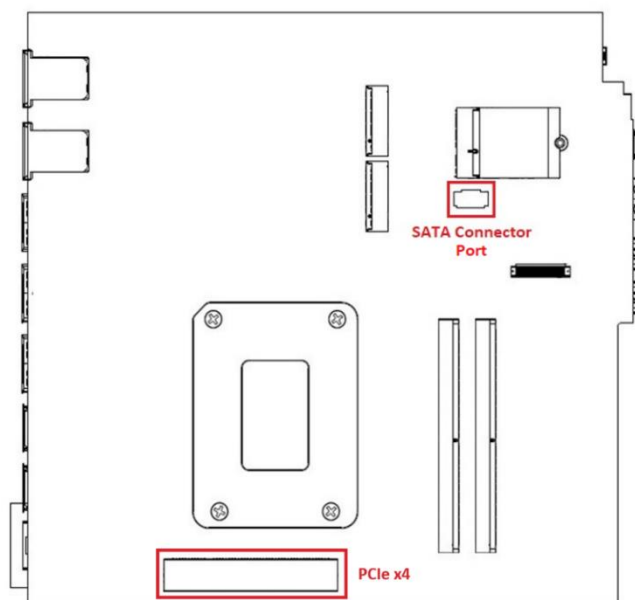
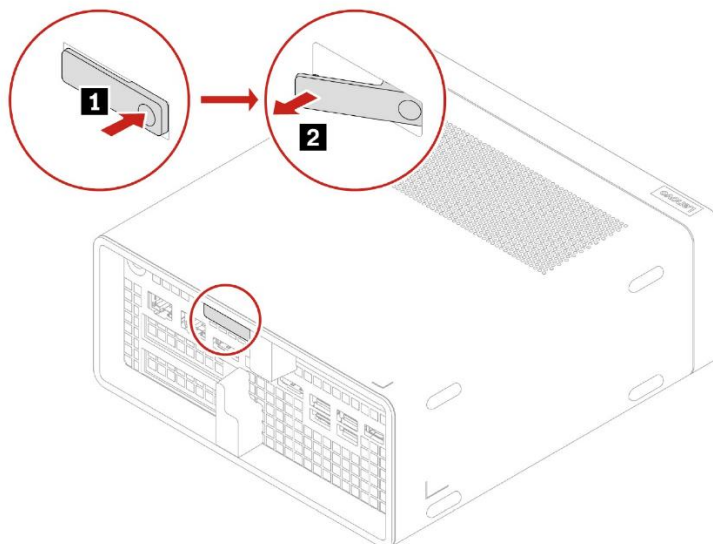

Figure 14 - P3 Ultra Chassis with SATA Bracket Installed



### **Accessing SATA port:**

1. Power down the system. Remove the power cable and all attached devices and cables from the system. Locate the chassis opening lever on the back of the system. Push in one side of the lever and pull on the extended lever.



2. While pulling on the lever, hold the chassis body in place until the motherboard assembly slides out of the chassis shell.

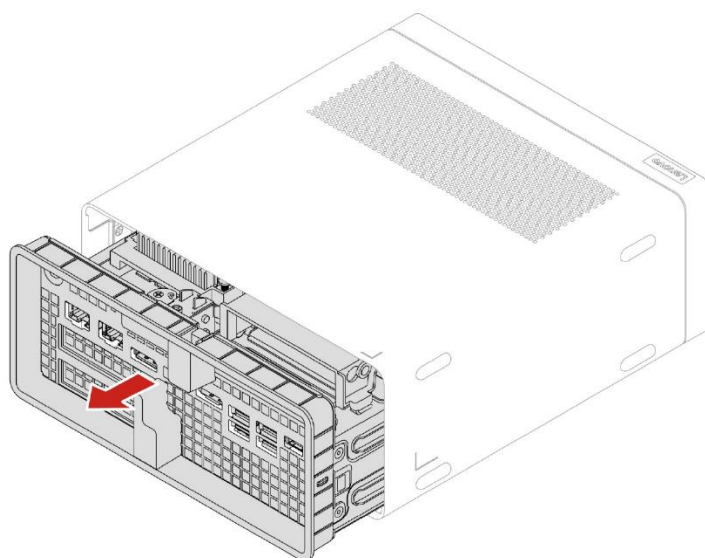



3. The M.2 NVMe heat sink is now accessible as seen in the image below. To access the motherboard SATA port, remove the heat sink by squeezing the locking handle and pull up on the heat sink.

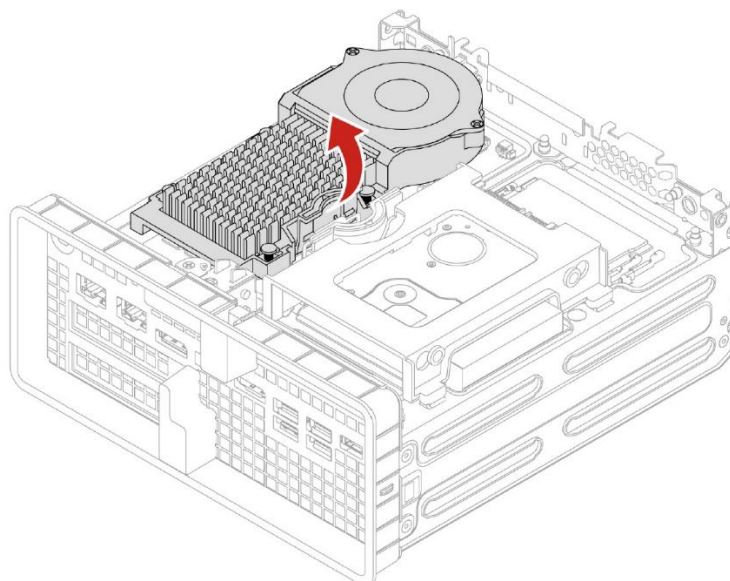

4. The SATA connection is ribbon-style, so the cable and port should be handled with care. Whenever inserting or removing the ribbon cable, lift the black flap to release the cable (See Figure 15 below).

Figure 15 - P3 Ultra SATA Port Callout

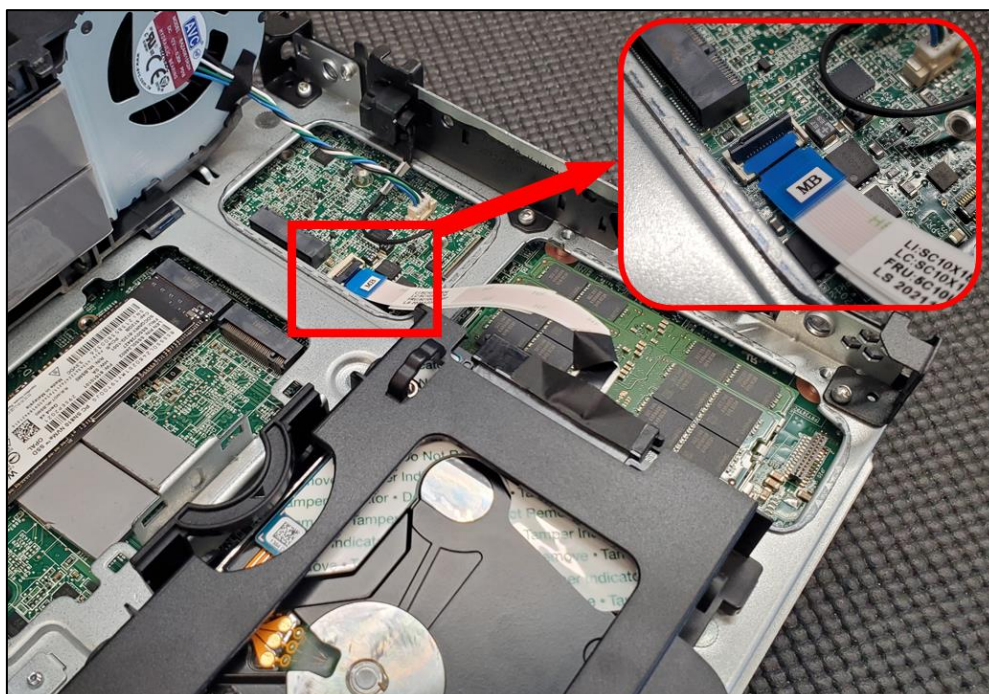



## Removing/Installing the SATA Drive:

1. To remove the drive, unplug the ribbon cable from the system and drive. Squeeze the locking handle and pull up on the drive carrier. When the carrier is free, remove it from the system and turn it over.

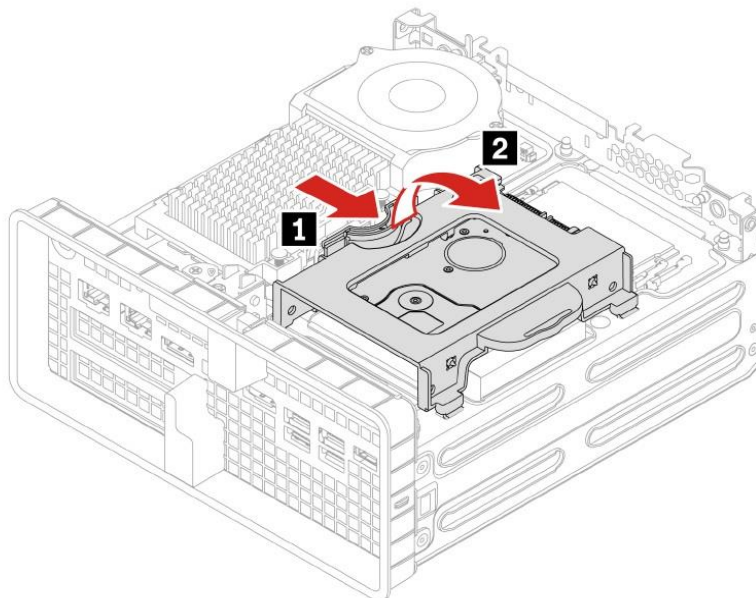

2. Gently stretch the drive carrier apart until the drive comes loose from the screw hole pins. Lift the drive up and out of the carrier.

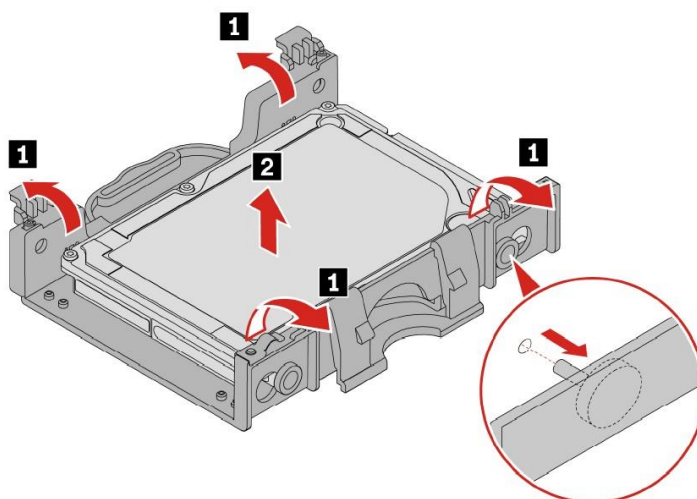

3. Reverse the steps to install a new drive.

---

## Section 6 – RAID Levels

### **General:**

- Before creating or altering a RAID config, always backup important data to an external location to prevent accidental data loss.
- A given array should not mix drive types or logical sizes. It is recommended to only use drives officially supported by Lenovo for the given platform.
- Each RAID level requires a certain minimum and or maximum number of drives. If altering the system storage devices after purchase or a previous configuration, it will be necessary to verify the proper types and number of devices for a desired RAID configuration have been installed. Altering or creating an array may require any existing OS to be reinstalled.
- P3 Tower, P3 Ultra, and P3 Tiny utilize Intel Rapid Storage Technology (RST) for configuring RAID.

### **P3 Tower:**

- At the time of writing there are no add-in RAID controllers certified on this platform.
- At the time of writing, the following drive quantities are supported for the respective SATA RAID levels:
  - RAID 0 & RAID 1 - Two SATA drives
  - RAID 5 - Three SATA drives
  - RAID 10 - Four SATA drives
- Only drives in the two onboard Gen 4 M.2 slots can be utilized together in a RAID configuration. RAID configurations utilizing both onboard and AIC M.2 drives are not supported.

The table below shows various RAID levels supported on each P3 platform.

*Table 4 - P3 Series RAID Capabilities*

<b>System</b>	<b>Max # of RAIDable M.2 NVMe Drives</b>	<b>M.2 NVMe RAID Levels</b>	<b>Max # of RAIDable SATA Drives</b>	<b>SATA RAID Levels</b>
<b>P3 Tower</b>	2	0,1	4*	0,1,5,10**
<b>P3 Ultra</b>	2	0,1	0	N/A
<b>P3 Tiny</b>	2	0,1	0	N/A

\*A fourth SATA drive bay will prevent M.2 2280 sized drives from being installed in the two onboard M.2 slots, reducing max number of supported M.2 NVMe drives to one (installed in an add-in card). See reference picture in Section 4.

\*\*Depending on number of SATA drives installed in the system.

## Section 7 – Configuring RAID

Please refer to the following steps to configure RAID for both NVMe and SATA drives. Examples may show configurations that are not possible on all systems. **Backup any important data before editing RAID configurations!**

1. Boot into the BIOS by pressing the function F1 key at the “Lenovo” splash screen.



2. Select “System Summary” and scroll down to verify BIOS is recognizing all the drives installed in the system.

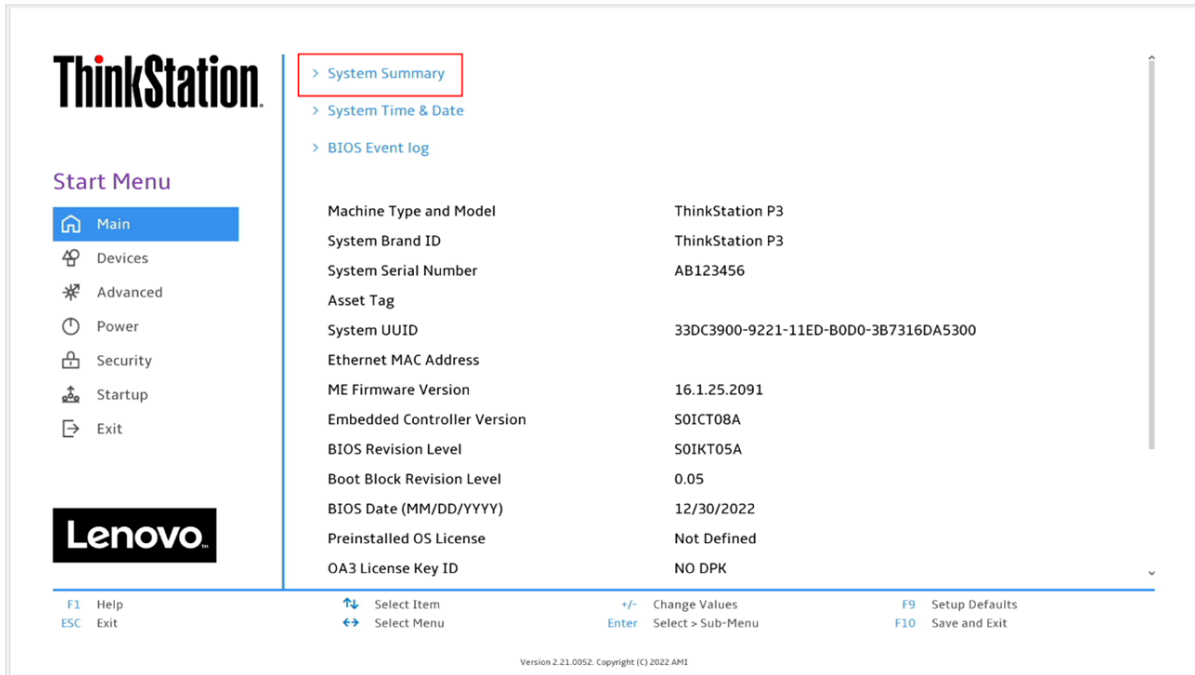

The screenshot shows the BIOS System Summary screen. The 'System Summary' menu item is highlighted with a red box. The screen displays the following system information:

Machine Type and Model	ThinkStation P3
System Brand ID	ThinkStation P3
System Serial Number	AB123456
Asset Tag	
System UUID	33DC3900-9221-11ED-B0D0-3B7316DA5300
Ethernet MAC Address	
ME Firmware Version	16.1.25.2091
Embedded Controller Version	SOICT08A
BIOS Revision Level	SOIKT05A
Boot Block Revision Level	0.05
BIOS Date (MM/DD/YYYY)	12/30/2022
Preinstalled OS License	Not Defined
OA3 License Key ID	NO DPK

Navigation keys at the bottom: F1 Help, ESC Exit, Select Item, Select Menu, Change Values, Enter Select > Sub-Menu, F9 Setup Defaults, F10 Save and Exit.



The screenshot shows the BIOS System Summary screen with the drive information section highlighted by a red box. The screen displays the following system information:

CPU Core Count	24
Installed Memory	8192 MB
Memory Bus Speed	4400 MHz
Active Video	PEG
Onboard Audio	Enabled
Onboard Ethernet	Enabled
CPU Fan	Operating
System Fan	Operating
Aux Fan	Operating
Aux Fan 2	Operating
M.2 Drive 1	SAMSUNG MZVLB256HBHQ-000L7
M.2 Drive 2	SAMSUNG MZVLB256HBHQ-000L7
PCIe Drive 1	None
PCIe Drive 2	None
SATA Drive 1	None
SATA Drive 2	None
SATA Drive 3	None
SATA Drive 4	None

Navigation keys at the bottom: F1 Help, ESC Exit, Select Item, Select Menu, Change Values, Enter Select > Sub-Menu, F9 Setup Defaults, F10 Save and Exit.

**Note:** From this point forward, the examples will utilize the M.2 NVMe drives. The process is the same for both drive types.

3. Select the “Devices” menu at the BIOS main screen setup utility and then select “Storage Setup”.

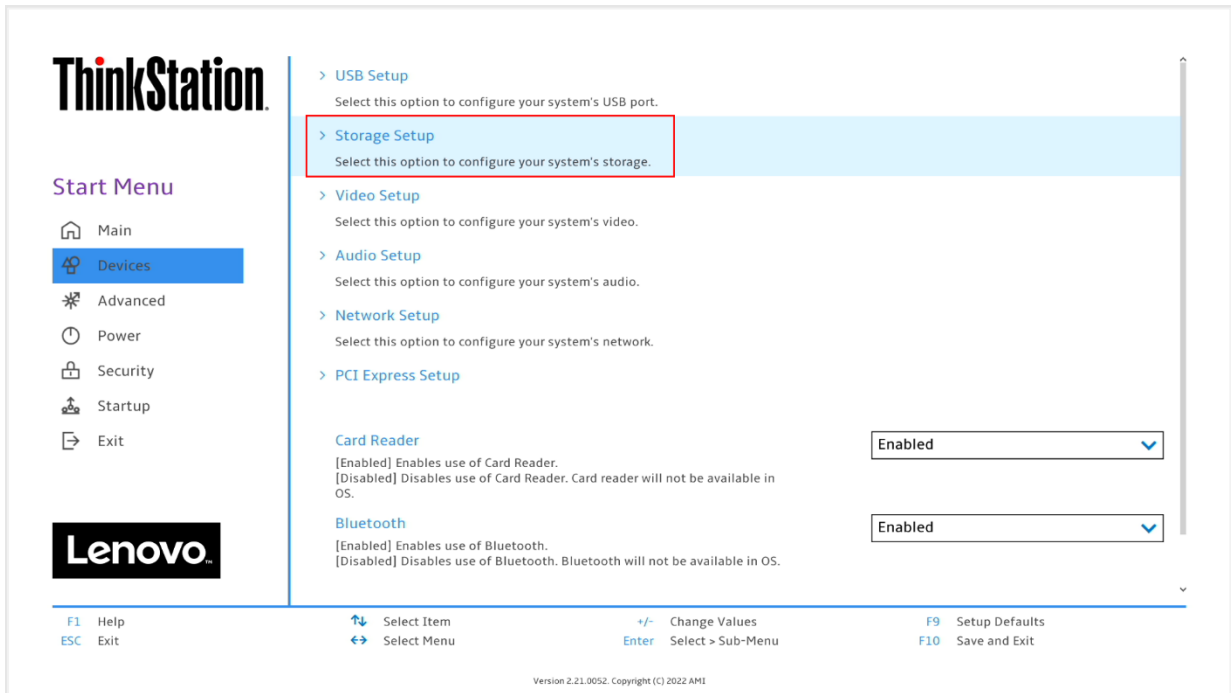

4. In the “Storage Setup” menu, select “Configure Storage as” and change or verify the option is set to “RAID”.

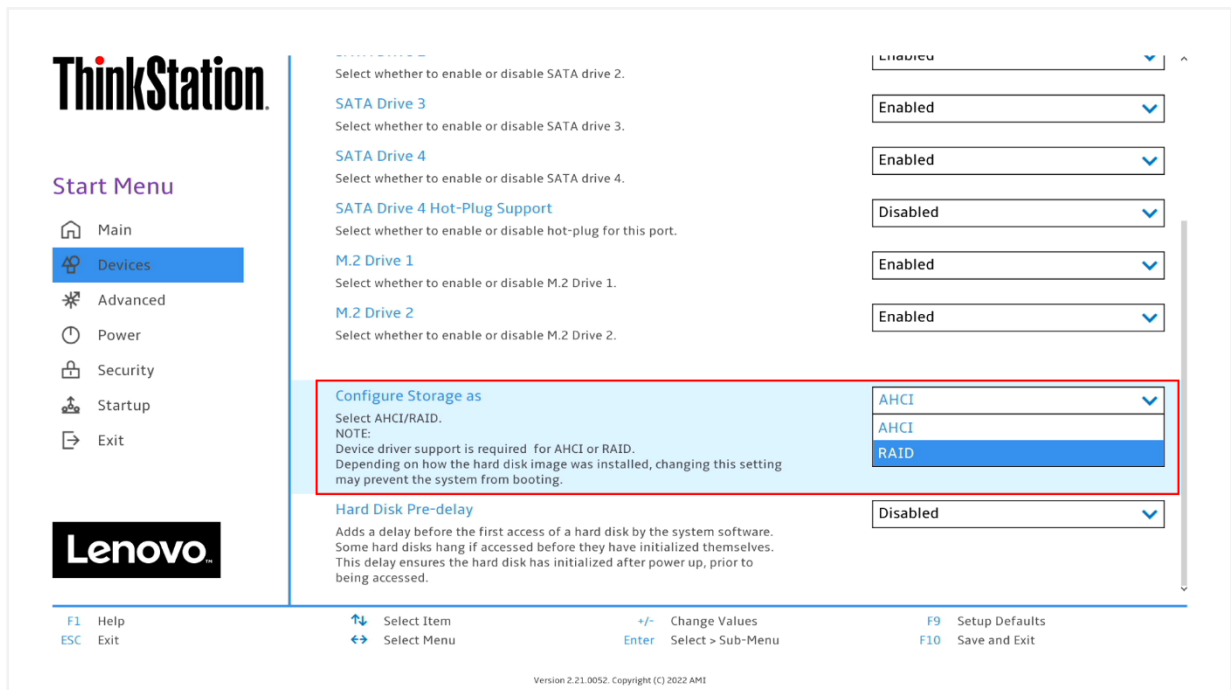

**Notes:** In order to Secure Erase any drives, the ‘Configure Storage as’ option must be set to ‘AHCI’ mode. Changing storage modes may cause issues with boot OS and data on existing drives.

- When selecting to enable RAID the system will prompt a warning that changing the setting may result in the failure of the system to boot. Select “Yes” to continue.

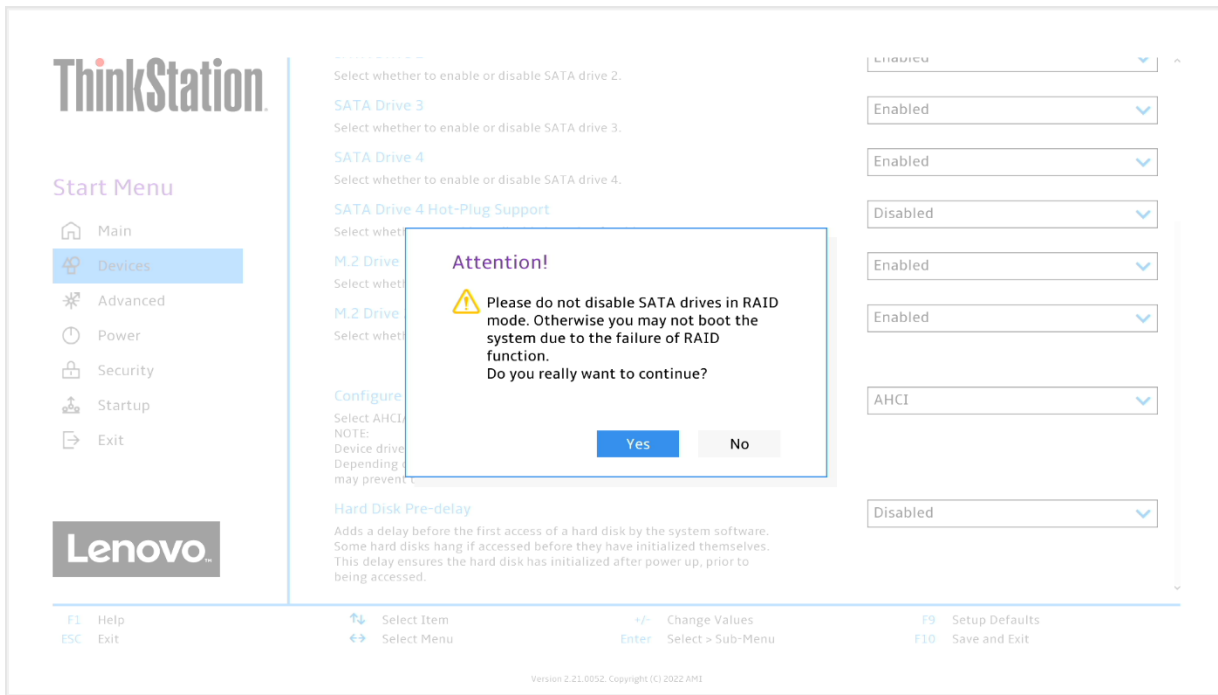

- Press F10 to save and Exit BIOS setup.

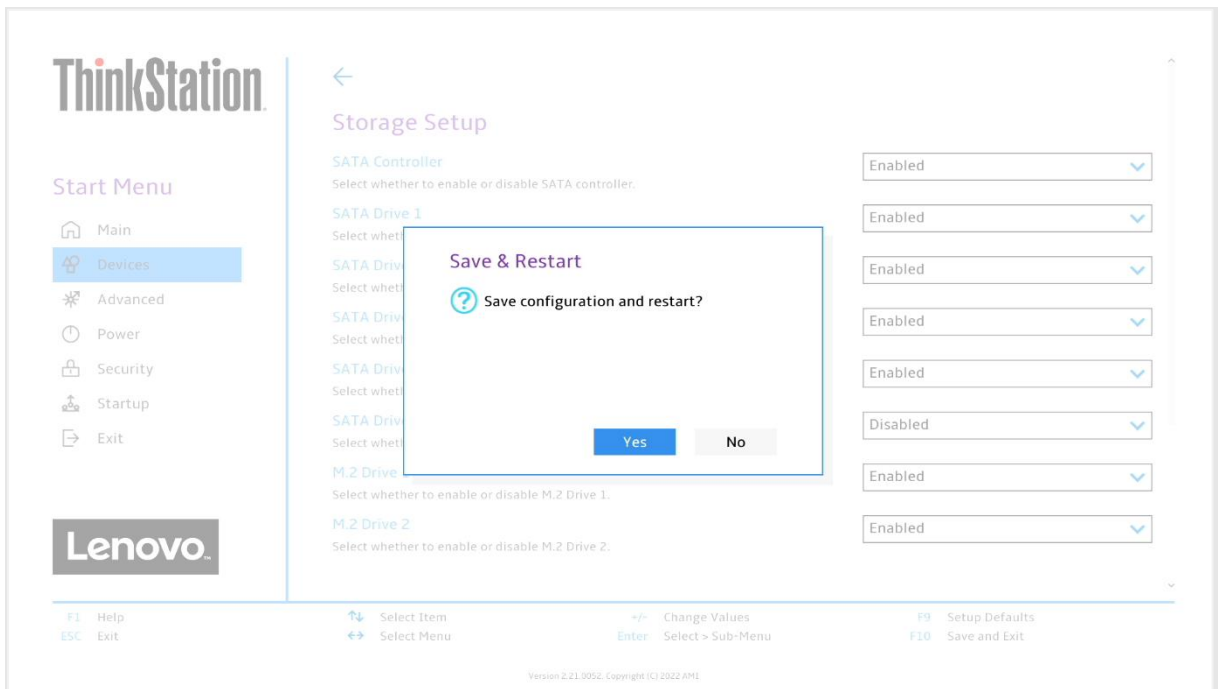

- As the system reboots, press the function F1 key at the Lenovo splash screen to enter the BIOS setup. Select the “Devices” menu at the BIOS main screen setup utility and then “Intel(R) Rapid Storage Technology”.

The screenshot shows the BIOS Setup Utility interface. On the left is the 'Start Menu' with options: Main, Devices (highlighted), Advanced, Power, Security, Startup, and Exit. The main area displays various settings for SATA and M.2 drives, including 'SATA Drive 4', 'SATA Drive 4 Hot-Plug Support', 'M.2 Drive 1', 'M.2 Drive 2', and 'Configure Storage as'. The 'Intel(R) Rapid Storage Technology' option is highlighted with a red box. Below it is the 'Hard Disk Pre-delay' setting. The bottom of the screen shows navigation keys: F1 Help, ESC Exit, arrow keys for Select Item and Select Menu, +/- for Change Values, Enter for Select > Sub-Menu, F9 Setup Defaults, and F10 Save and Exit. The version number 'Version 2.21.0052. Copyright (C) 2022 AMI' is visible at the bottom.

- Verify all the desired drives are available.

The screenshot shows the 'Intel(R) Rapid Storage Technology' screen in the BIOS Setup Utility. The main title is 'Intel(R) Rapid Storage Technology' with the driver version 'Intel(R) RST 19.5.0.5676 RST VMD Driver'. There are two main sections: 'Create RAID Volume' and 'Non-RAID Physical Disks'. The 'Non-RAID Physical Disks' section lists two disks: 'PCIe 1.0, SAMSUNG MZVLB256HBHQ-000L7 54ELNF4M929926, 238.4GB' and 'PCIe 2.0, SAMSUNG MZVLB256HBHQ-000L7 54ELNF4M929640, 238.4GB'. Both disk entries are highlighted with a red box. The bottom of the screen shows navigation keys: F1 Help, ESC Exit, arrow keys for Select Item and Select Menu, +/- for Change Values, Enter for Select > Sub-Menu, F9 Setup Defaults, and F10 Save and Exit. The version number 'Version 2.21.0052. Copyright (C) 2022 AMI' is visible at the bottom.



9. If all the disks installed are not shown as available, it may be necessary to clear any previous data from the disks. If no arrays have been created previously but there is an existing volume shown, it will be necessary to delete any previous arrays. Advance to step 15 to complete the process to delete any arrays. Return and proceed to step 10 once the desired drives are available.

10. Select "Create RAID Volume".

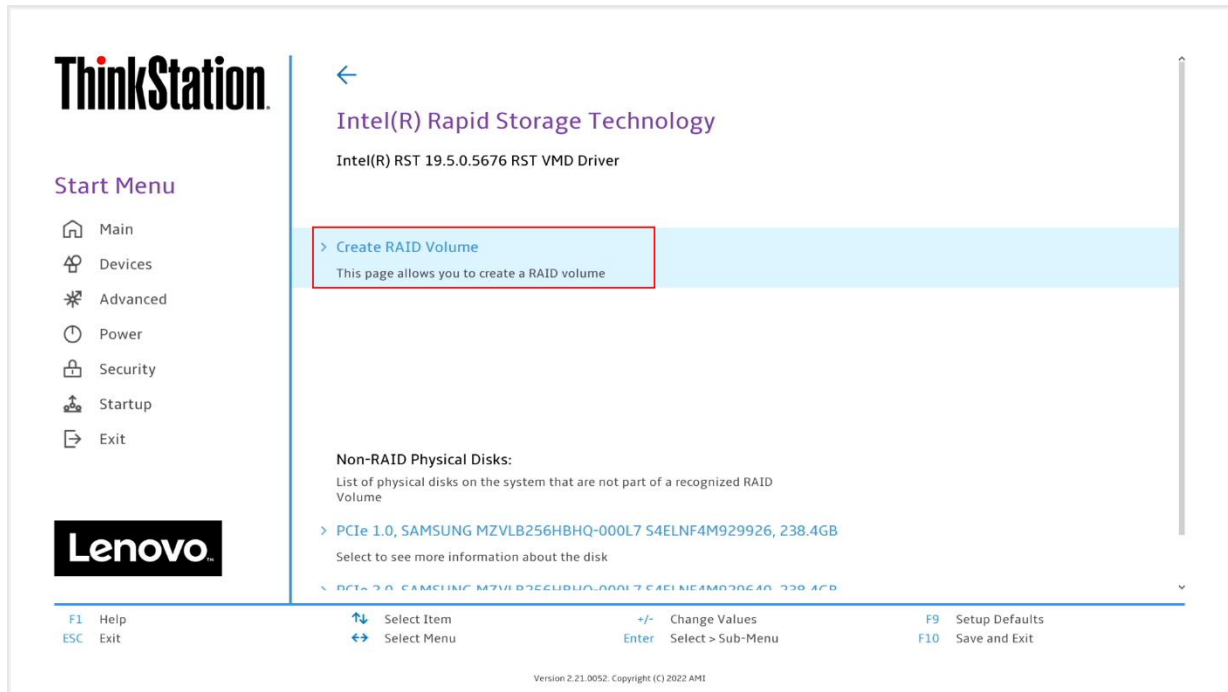

11. Choose a name for the volume.

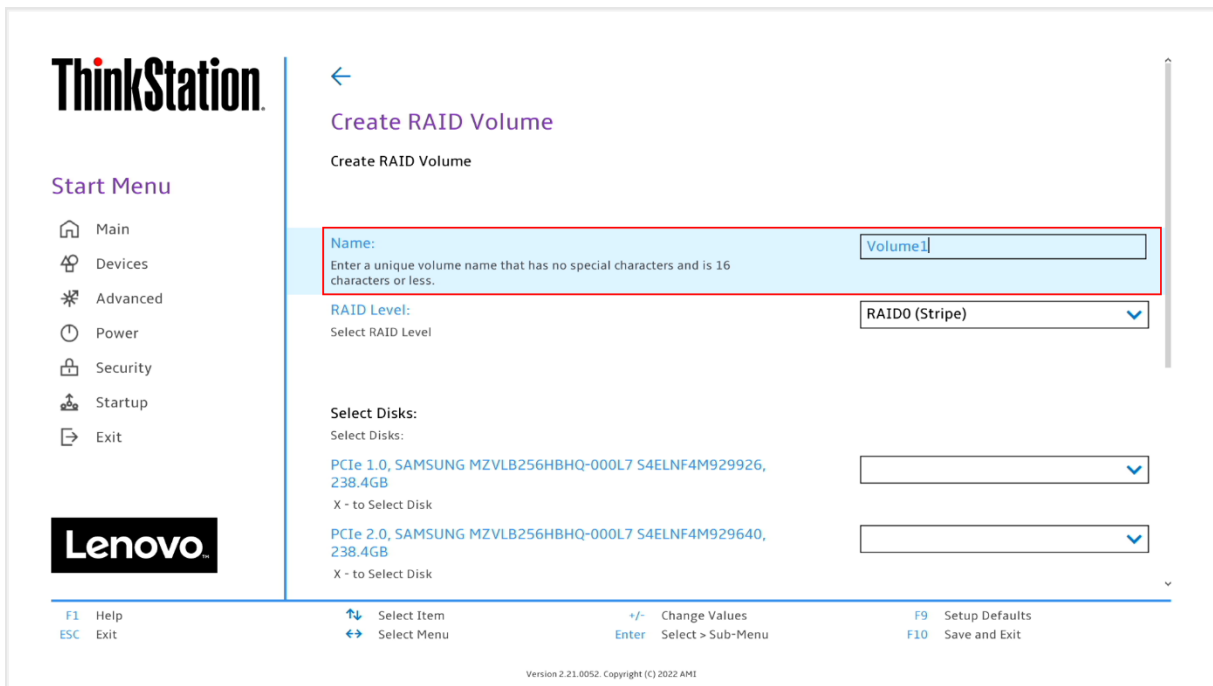

12. Select the drop-down box for “RAID Level” and select the desired RAID level. The RAID level options displayed are based on the type and number of drives available in the system.

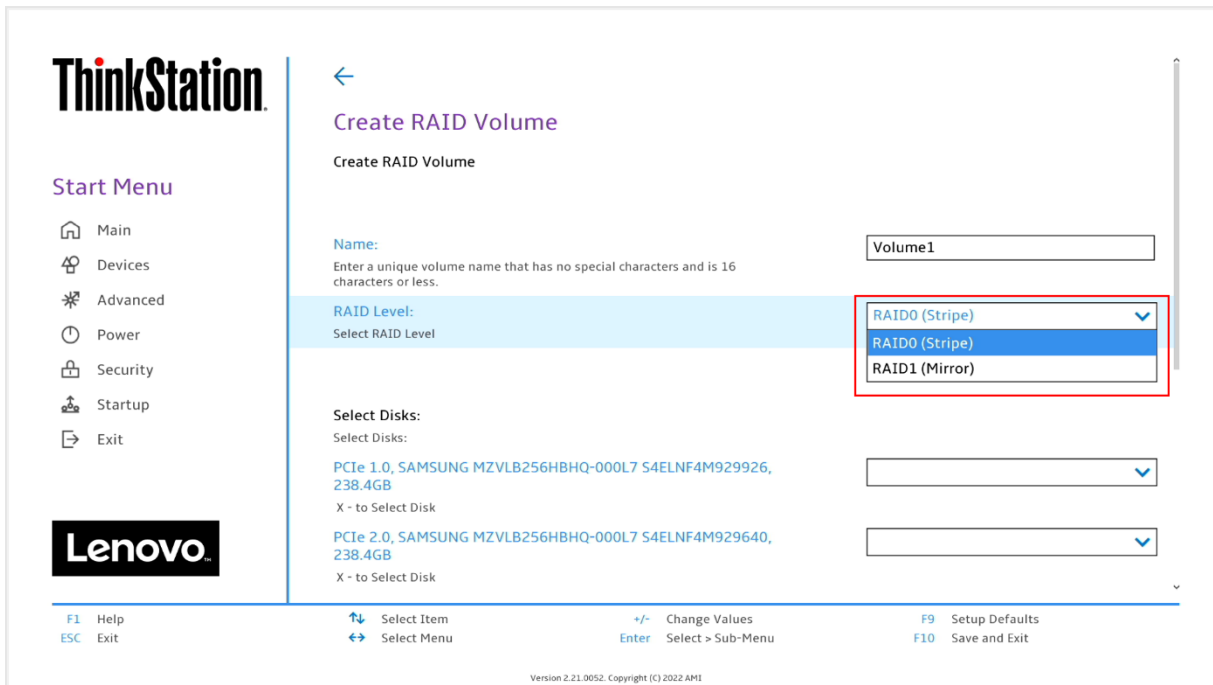

13. On the same page, select the drop-down box for each drive and select “X” to add the drive to the array. Once all the required drives are added, select “Create Volume”. Unselected drives will appear in an OS like normal.

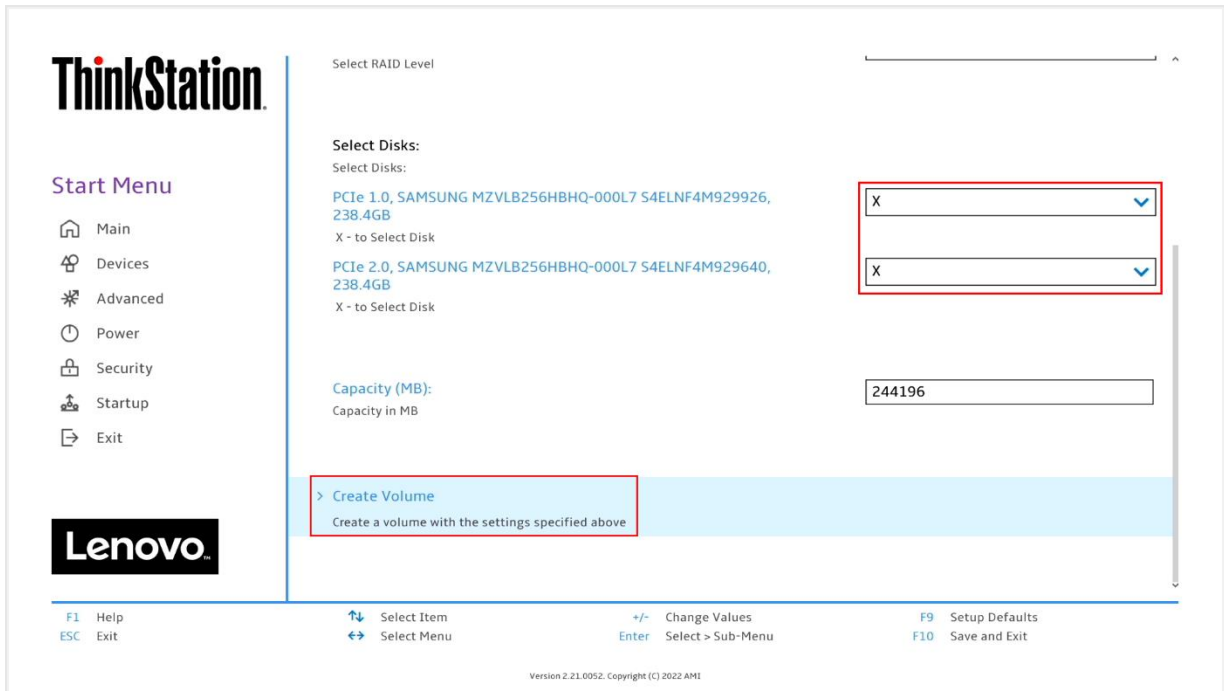

14. From the opening page of the “Intel(R) Rapid Storage Technology”, verify the volume was created properly.

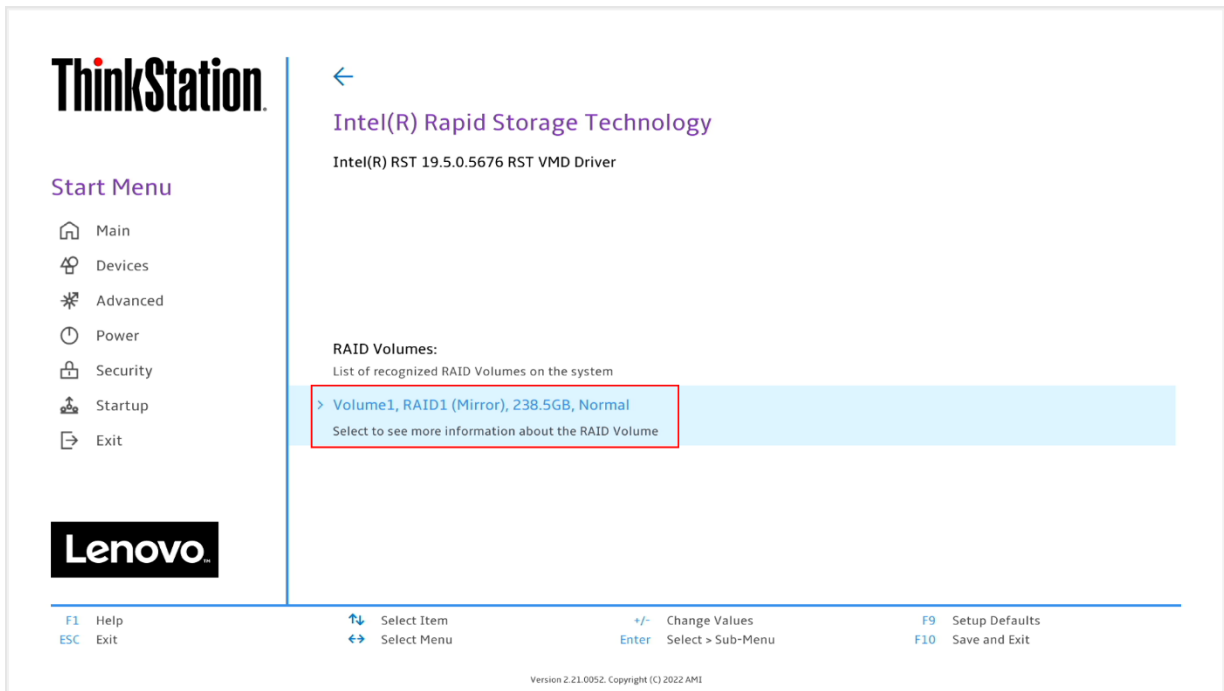

15. To delete an array, select a displayed volume to view information about it.

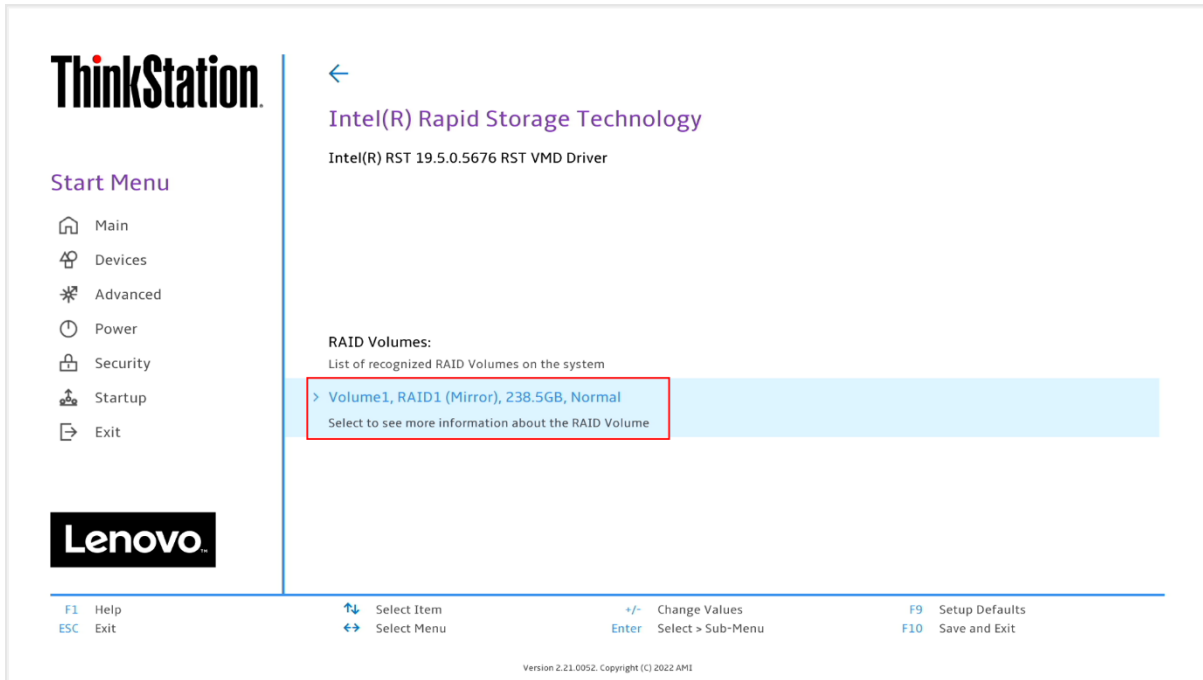

16. Select the "Delete" option.

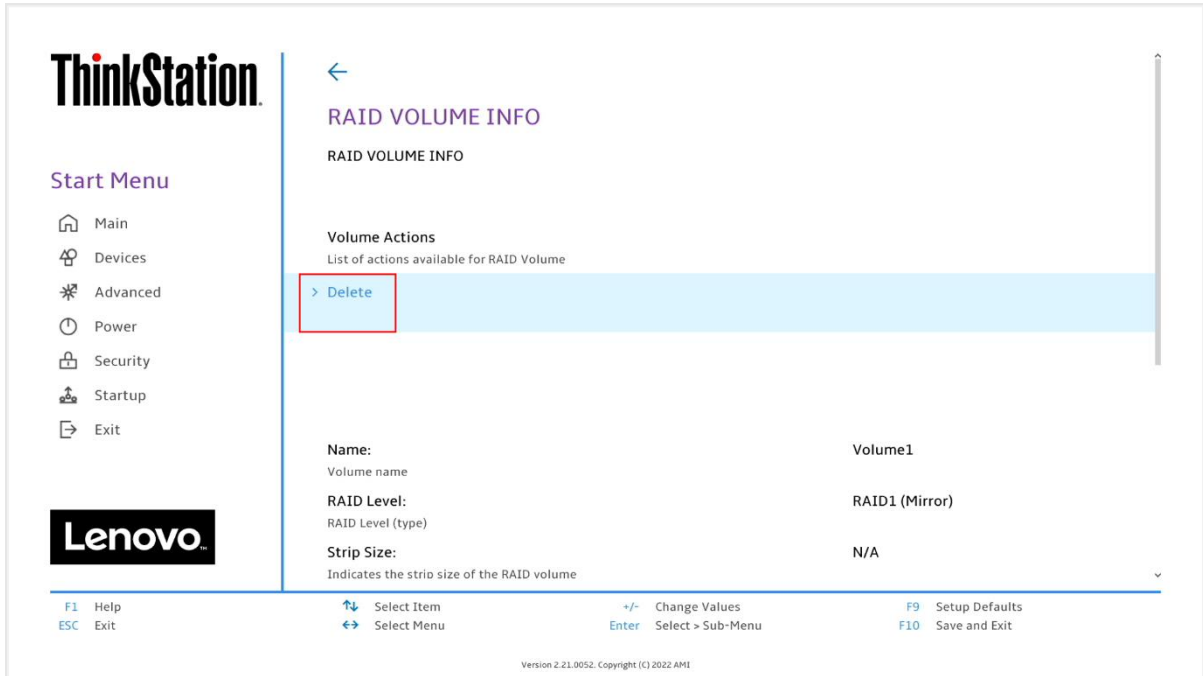

17. Select “Yes” to confirm the deletion of the volume.

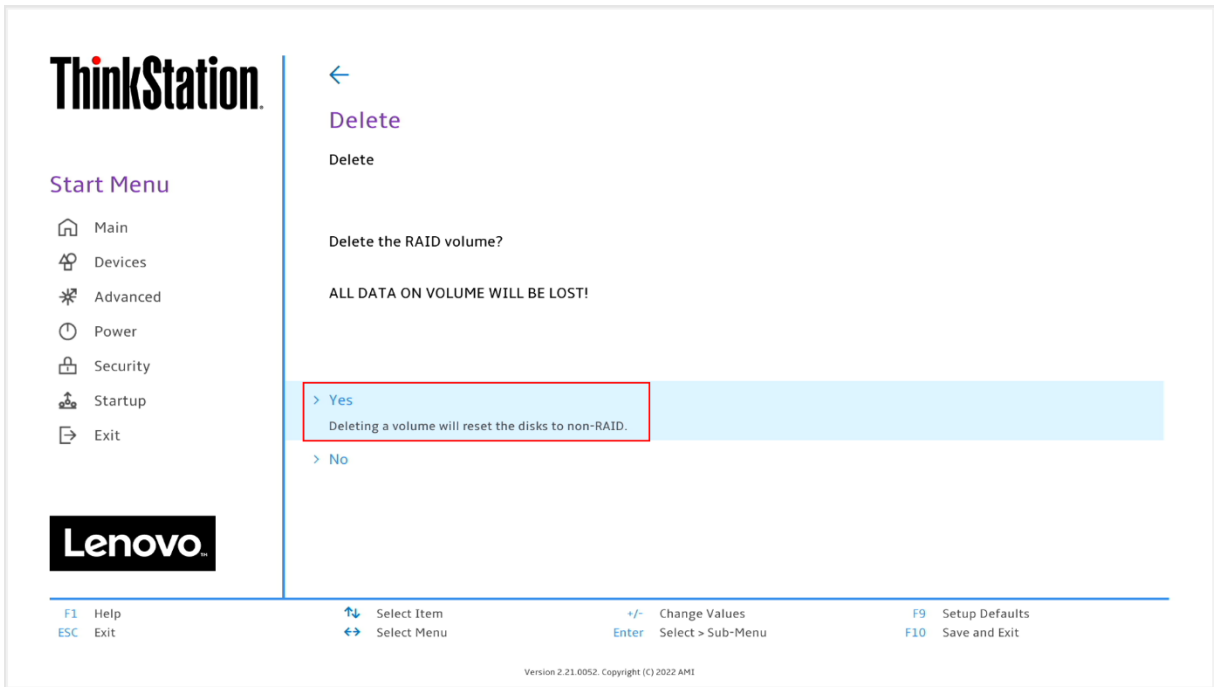

18. To verify the array was deleted, return the opening page of the “Intel(R) Rapid Storage Technology” and verify the drives are once again seen as available for the creation of a new array.

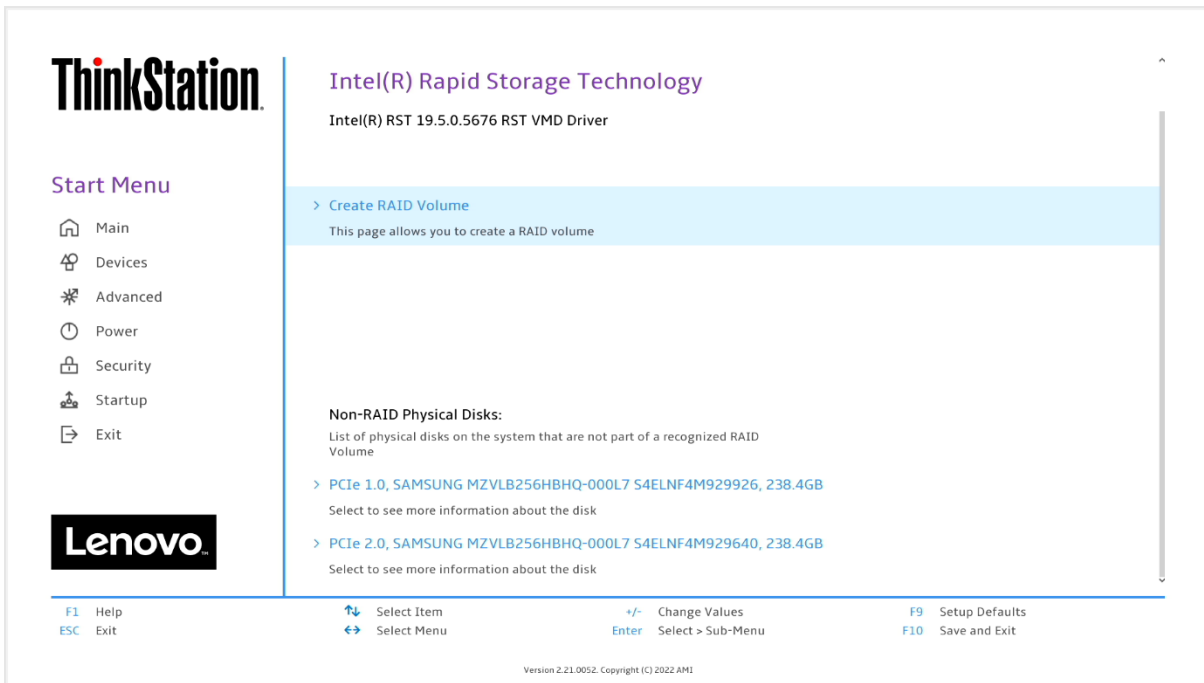

**Note:** The user may not see the RAID array show up in the BIOS boot sequence until after a bootable operating system has been installed on the array.

---

## Section 8 – Document Revision History

Version	Date	Author	Updates
v1.0	5/25/23	Chris C	Initial Release
V1.1	9/12/23	Chris C	Updated information on P3 Tower RAID
V1.2	10/23/23	Chris C	Minor updates and revised P3 Tower SATA RAID notes