

ThinkPad

Hardware Maintenance Manual

ThinkPad T430s and T430si

Note: Before using this information and the product it supports, be sure to read the general information under Appendix A “Notices” on page 107.

Second Edition (October 2012)

© Copyright Lenovo 2012.

LIMITED AND RESTRICTED RIGHTS NOTICE: If data or software is delivered pursuant a General Services Administration “GSA” contract, use, reproduction, or disclosure is subject to restrictions set forth in Contract No. GS-35F-05925.

Contents

About this manual	iii	Hard disk password	35
Chapter 1. Safety information	1	Supervisor password	35
General safety	1	How to remove the power-on password	36
Electrical safety	1	How to remove the hard disk password	36
Safety inspection guide	2	Power management	37
Handling devices that are sensitive to electrostatic discharge	3	Screen blank mode (for the Windows 7 operating system only)	37
Grounding requirements	4	Sleep mode	37
Safety notices (multilingual translations)	4	Hibernation mode	37
Laser compliance statement (multilingual translations)	17	Symptom-to-FRU index	38
Chapter 2. Important service information	23	Numeric error codes	39
Strategy for replacing FRUs	23	Error messages	40
Strategy for replacing a hard disk drive, a solid-state drive, or an mSATA solid-state drive	23	Beep symptoms	40
Important notice for replacing a system board	24	No-beep symptoms	41
How to use error message	24	LCD-related symptoms	41
Strategy for replacing FRUs for CTO, CMV, and GAV	24	Intermittent problems	42
Product definition	24	Undetermined problems	42
FRU identification for CTO, CMV, and GAV products	25	Chapter 5. Status indicators	43
Chapter 3. General checkout	27	Chapter 6. Fn key combinations	45
What to do first	27	Chapter 7. Locations	47
Checkout guide	28	Locating computer controls, connectors, and indicators	47
Lenovo Solution Center	28	Front view	47
Quick test programs	28	Rear view	48
UEFI diagnostic program	29	Bottom view	48
Bootable diagnostic programs	29	Locating FRUs and CRUs	49
Power system checkout	30	Major FRUs and CRUs	50
Checking the ac power adapter	30	LCD FRUs	52
Checking operational charging	31	Looking up FRU information	53
Checking the battery pack	31	Chapter 8. FRU replacement notices	55
Checking the backup battery	32	Screw notices	55
Chapter 4. Related service information	33	Retaining serial numbers	56
Restoring the factory contents by using Recovery Disc Set	33	Restoring the serial number of the system unit	56
Using the Windows recovery programs on the Windows 8 operating system	34	Retaining the UUID	57
Passwords	35	Reading or writing the ECA information	57
Power-on password	35	Chapter 9. Removing or replacing a FRU	59
		General guidelines	59
		Before servicing the computer	60
		Removing the SIM card	60
		1010 Battery pack	60

1020 Serial Ultrabay Slim device or blank bezel	61	1150 System board, thermal fan assembly, 34-mm ExpressCard reader, and base cover	90
1030 Solid-state drive or hard disk drive	62	2010 LCD bezel assembly	95
1040 Memory module	64	2020 LCD panel	96
1050 PCI Express Mini Card for wireless LAN	65	2030 Integrated camera, microphone, or hall sensor card	98
1060 PCI Express Mini Card for wireless WAN or mSATA solid-state drive	68	2040 LED sub card	100
1070 4-in-1 media card reader or ExpressCard reader	75	2050 LCD cable	101
1080 Keyboard	75	2060 Hinge kit	102
1090 Backup battery	80	2070 LED cable	103
1100 Keyboard bezel assembly with fingerprint reader, smart card reader, and speaker assembly	81	2080 Antenna kit and LCD rear cover assembly	104
1110 LCD unit	85	Appendix A. Notices	107
1120 DC-in sub card	87	Electronic emissions notices	108
1130 Bluetooth daughter card (BDC-4.0)	88	Trademarks	108
1140 Bluetooth wireless radio switch FPC	89		

About this manual

This manual contains service and reference information for the following ThinkPad® products.

ThinkPad T430s and T430si Machine types (MT) 2352, 2353, 2354, 2355, 2356, 2357, and 2358

Use this manual along with the advanced diagnostic tests to troubleshoot problems.

Important: This manual is intended only for trained service technicians who are familiar with ThinkPad products. Use this manual along with the advanced diagnostic tests to troubleshoot problems effectively. Before servicing a ThinkPad product, be sure to read all the information under Chapter 1 “Safety information” on page 1 and Chapter 2 “Important service information” on page 23.

Chapter 1. Safety information

This chapter presents following safety information that you need to be familiar with before you service a ThinkPad notebook computer.

- “General safety” on page 1
- “Electrical safety” on page 1
- “Safety inspection guide” on page 2
- “Handling devices that are sensitive to electrostatic discharge” on page 3
- “Grounding requirements” on page 4
- “Safety notices (multilingual translations)” on page 4
- “Laser compliance statement (multilingual translations)” on page 17

General safety

Follow these rules to ensure general safety:

- Observe good housekeeping in the area of the machines during and after maintenance.
- When lifting any heavy object:
 1. Make sure that you can stand safely without slipping.
 2. Distribute the weight of the object equally between your feet.
 3. Use a slow lifting force. Never move suddenly or twist when you attempt to lift.
 4. Lift by standing or by pushing up with your leg muscles; this action removes the strain from the muscles in your back. *Do not attempt to lift any object that weighs more than 16 kg (35 lb) or that you think is too heavy for you.*
- Do not perform any action that causes hazards to the customer, or that makes the equipment unsafe.
- Before you start the machine, make sure that other service technicians and the customer's personnel are not in a hazardous position.
- Place removed covers and other parts in a safe place, away from all personnel, while you are servicing the machine.
- Keep your toolbox away from walk areas so that other people will not trip over it.
- Do not wear loose clothing that can be trapped in the moving parts of a machine. Make sure that your sleeves are fastened or rolled up above your elbows. If your hair is long, fasten it.
- Insert the ends of your necktie or scarf inside clothing or fasten it with a nonconductive clip, about 8 centimeters (3 inches) from the end.
- Do not wear jewelry, chains, metal-frame eyeglasses, or metal fasteners for your clothing.

Attention: Metal objects are good electrical conductors.

- Wear safety glasses when you are hammering, drilling, soldering, cutting wire, attaching springs, using solvents, or working in any other conditions that might be hazardous to your eyes.
- After service, reinstall all safety shields, guards, labels, and ground wires. Replace any safety device that is worn or defective.
- Reinstall all covers correctly before returning the machine to the customer.
- Fan louvers on the machine help to prevent overheating of internal components. Do not obstruct fan louvers or cover them with labels or stickers.

Electrical safety

Observe the following rules when working on electrical equipment.

Important: Use only approved tools and test equipment. Some hand tools have handles covered with a soft material that does not insulate you when working with live electrical currents. Many customers have, near

their equipment, rubber floor mats that contain small conductive fibers to decrease electrostatic discharges. Do not use this type of mat to protect yourself from electrical shock.

- Find the room emergency power-off (EPO) switch, disconnecting switch, or electrical outlet. If an electrical accident occurs, you can then operate the switch or unplug the power cord quickly.
- Do not work alone under hazardous conditions or near equipment that has hazardous voltages.
- Disconnect all power before:
 - Performing a mechanical inspection
 - Working near power supplies
 - Removing or installing main units
- Before you start to work on the machine, unplug the power cord. If you cannot unplug it, ask the customer to power-off the wall box that supplies power to the machine, and to lock the wall box in the off position.
- If you need to work on a machine that has *exposed* electrical circuits, observe the following precautions:
 - Ensure that another person, familiar with the power-off controls, is near you.

Attention: Another person must be there to switch off the power, if necessary.

- Use only one hand when working with powered-on electrical equipment; keep the other hand in your pocket or behind your back.

Attention: An electrical shock can occur only when there is a complete circuit. By observing the above rule, you may prevent a current from passing through your body.

- When using testers, set the controls correctly and use the approved probe leads and accessories for that tester.
- Stand on suitable rubber mats (obtained locally, if necessary) to insulate you from grounds such as metal floor strips and machine frames.

Observe the special safety precautions when you work with very high voltages; Instructions for these precautions are in the safety sections of maintenance information. Use extreme care when measuring high voltages.

- Regularly inspect and maintain your electrical hand tools for safe operational condition.
- Do not use worn or broken tools and testers.
- *Never assume* that power has been disconnected from a circuit. First, *check* that it has been powered off.
- Always look carefully for possible hazards in your work area. Examples of these hazards are moist floors, nongrounded power extension cables, power surges, and missing safety grounds.
- Do not touch live electrical circuits with the reflective surface of a plastic dental mirror. The surface is conductive; such touching can cause personal injury and machine damage.
- Do not service the following parts *with the power on* when they are removed from their normal operating places in a machine:
 - Power supply units
 - Pumps
 - Blowers and fans
 - Motor generators
 - Similar units to listed aboveThis practice ensures correct grounding of the units.
- If an electrical accident occurs:
 - Use caution; do not become a victim yourself.
 - Switch off power.
 - Send another person to get medical aid.

Safety inspection guide

The purpose of this inspection guide is to assist you in identifying potentially unsafe conditions. As each machine was designed and built, required safety items were installed to protect users and service technicians from injury. This guide addresses only those items. You should use good judgment to identify potential safety hazards due to attachment of non-ThinkPad features or options not covered by this inspection guide.

If any unsafe conditions are present, you must determine how serious the apparent hazard could be and whether you can continue without first correcting the problem.

Consider these conditions and the safety hazards they present:

- Electrical hazards, especially primary power (primary voltage on the frame can cause serious or fatal electrical shock)
- Explosive hazards, such as a damaged CRT face or a bulging capacitor
- Mechanical hazards, such as loose or missing hardware

To determine whether there are any potentially unsafe conditions, use the following checklist at the beginning of every service task. Begin the checks with the power off, and the power cord disconnected.

Checklist:

1. Check exterior covers for damage (loose, broken, or sharp edges).
2. Power off the computer. Disconnect the power cord.
3. Check the power cord for:
 - a. A third-wire ground connector in good condition. Use a meter to measure third-wire ground continuity for 0.1 ohm or less between the external ground pin and the frame ground.
 - b. The power cord should be the authorized type specified for your computer. Go to: <http://www.lenovo.com/serviceparts-lookup>
 - c. Insulation must not be frayed or worn.
4. Check for cracked or bulging batteries.
5. Remove the cover.
6. Check for any obvious non-ThinkPad alterations. Use good judgment as to the safety of any non-ThinkPad alterations.
7. Check inside the unit for any obvious unsafe conditions, such as metal filings, contamination, water or other liquids, or signs of fire or smoke damage.
8. Check for worn, frayed, or pinched cables.
9. Check that the power-supply cover fasteners (screws or rivets) have not been removed or tampered with.

Handling devices that are sensitive to electrostatic discharge

Any computer part containing transistors or integrated circuits (ICs) should be considered sensitive to electrostatic discharge (ESD.) ESD damage can occur when there is a difference in charge between objects. Protect against ESD damage by equalizing the charge so that the machine, the part, the work mat, and the person handling the part are all at the same charge.

Notes:

1. Use product-specific ESD procedures when they exceed the requirements noted here.
2. Make sure that the ESD protective devices you use have been certified (ISO 9000) as fully effective.

When handling ESD-sensitive parts:

- Keep the parts in protective packages until they are inserted into the product.
- Avoid contact with other people.
- Wear a grounded wrist strap against your skin to eliminate static on your body.
- Prevent the part from touching your clothing. Most clothing is insulative and retains a charge even when you are wearing a wrist strap.
- Use a grounded work mat to provide a static-free work surface. The mat is especially useful when handling ESD-sensitive devices.
- Select a grounding system, such as those listed below, to provide protection that meets the specific service requirement.

Note: The use of a grounding system to guard against ESD damage is desirable but not necessary.

- Attach the ESD ground clip to any frame ground, ground braid, or green-wire ground.
- When working on a double-insulated or battery-operated system, use an ESD common ground or reference point. You can use coax or connector-outside shells on these systems.
- Use the round ground prong of the ac plug on ac-operated computers.

Grounding requirements

Electrical grounding of the computer is required for operator safety and correct system function. Proper grounding of the electrical outlet can be verified by a certified electrician.

Safety notices (multilingual translations)

The safety notices in this section are provided in the following languages:

- English
- Arabic
- Brazilian Portuguese
- French
- German
- Hebrew
- Japanese
- Korean
- Spanish
- Traditional Chinese



DANGER

Before the computer is powered on after FRU replacement, make sure that all screws, springs, and other small parts are in place and are not left loose inside the computer. Verify this by shaking the computer and listening for rattling sounds. Metallic parts or metal flakes can cause electrical short circuits.



DANGER

Some standby batteries contain a small amount of nickel and cadmium. Do not disassemble a standby battery, recharge it, throw it into fire or water, or short-circuit it. Dispose of the battery as required by local ordinances or regulations. Use only the battery in the appropriate parts listing. Use of an incorrect battery can result in ignition or explosion of the battery.



DANGER

The battery pack contains small amounts of nickel. Do not disassemble it, throw it into fire or water, or short-circuit it. Dispose of the battery pack as required by local ordinances or regulations. Use only the battery in the appropriate parts listing when replacing the battery pack. Use of an incorrect battery can result in ignition or explosion of the battery.



DANGER

The lithium battery can cause a fire, an explosion, or a severe burn. Do not recharge it, remove its polarized connector, disassemble it, heat it above 100°C (212°F), incinerate it, or expose its cell contents to water. Dispose of the battery as required by local ordinances or regulations. Use only the battery in the appropriate parts listing. Use of an incorrect battery can result in ignition or explosion of the battery.



DANGER

If the LCD breaks and the fluid from inside the LCD gets into your eyes or on your hands, immediately wash the affected areas with water for at least 15 minutes. Seek medical care if any symptoms from the fluid are present after washing.



DANGER

To avoid shock, do not remove the plastic cover that protects the lower part of the inverter card.



DANGER

Though the main batteries have low voltage, a short-circuited or grounded battery can produce enough current to burn personnel or combustible materials.



DANGER

Unless hot swap is allowed for the FRU being replaced, do as follows before removing it: power off the computer, unplug all power cords from electrical outlets, remove the battery pack, and disconnect any interconnecting cables.



قبل اعادة تشغيل الحاسب بعد الانتهاء من استبدال FRU، تأكد من أنه قد تم اعادة كل من المسامير و السوست وكل الأجزاء الصغيرة الأخرى في أماكنهم ولم يتم فقدهم داخل الحاسب. ويمكن التحقق من ذلك عن طريق هز الحاسب والاستماع لأي صوت صاخب يصدر منه. قد تؤدي الأجزاء أو الرقائق المعدنية الى حدوث دائرة قصر.



تحتوي بعض البطاريات الاحتياطية على كمية صغيرة من مادتي النيكل والكاديوم. لا تقم بفك أو اعادة شحن البطارية الاحتياطية ولا تقم أيضا بالقائها في النار أو الماء ولا تتسبب في احداث دائرة قصر بها. قم بالتخلص من البطارية كما هو موضح في القوانين المحلية. استخدم نوع البطارية المحدد والذي يوصى باستخدامه. حيث أنه قد يؤدي استخدام نوع بطارية غير صحيح الى اشتعالها أو انفجارها.



تحتوي حزمة البطارية على كمية صغيرة من مادة النيكل. لا تقم بفكها أو القاءها في النار أو الماء ولا تتسبب في احداث دائرة قصر بها. تخلص من حزمة البطارية وفقا لما هو موضح في القوانين المحلية. قم، عند استبدال حزمة البطارية، باستخدام الأنواع المحددة فقط والتي يوصى باستخدامها. حيث أنه قد يؤدي استخدام نوع بطارية غير صحيح الى اشتعالها أو انفجارها.



قد تتسبب بطارية الليثيوم في حدوث حريق أو انفجار أو حدوث حروق شديدة. لا تقم باعادة شحن البطارية أو ازالة موصل الاستقطاب الخاص بها ولا تحاول أيضا فكها أو تسخينها لأكثر من ١٠٠ درجة مئوية (٢١٢١ فهرنهايت) أو حرقها أو تعريض محتويات الخانة الخاصة بها للماء. قم بالتخلص من البطارية وفقا لما هو موضح في القوانين المحلية. استخدم نوع البطارية المحدد والذي يوصى باستخدامه. حيث أنه قد يؤدي استخدام نوع بطارية غير صحيح الى اشتعالها أو انفجارها.



إذا ما انكسرت شاشة LCD ولامس السائل الداخلي عينيك أو يديك، قم في الحال بغسلهما بالماء لمدة لا تقل عن ١٥ دقيقة. إذا ما وجدت أي أعراض بعد الغسل اطلب عندئذ المساعدة الطبية.



لتجنب التعرض لأي صدمات، لا تقم بإزالة الغطاء البلاستيكي الذي يحمي الجزء الأسفل من بطاقة العاكس.



خطر

على الرغم من أن البطاريات الرئيسية يكون لها جهد منخفض، إلا أنه قد تقوم البطاريات التي حدث قصور بها أو التي تم توصيلها أرضيا بإصدار تيار يكفي لحدوث حروق للأفراد أو تعرض المواد القابلة للاشتعال للحريق.



خطر

ما لم يتم السماح بالتبديل الفوري لأي FRU الجاري استبداله بدون ضرورة اغلاق النظام، قم بتنفيذ ما يلي قبل ازالته. قم بإيقاف تشغيل الحاسب ونزع كل أسلاك الطاقة من المخارج الكهربائية وقم أيضا بإزالة حزمة البطارية ثم قم بفصل أي كابلات متصلة.



PERIGO

Antes de ligar o computador após a substituição da FRU, certifique-se de que todos os parafusos, molas e outras peças pequenas estejam no lugar e não estejam soltos dentro do computador. Verifique isso sacudindo o computador e procurando ouvir sons de peças soltas. Peças metálicas ou lascas de metal podem causar curto-circuito.



PERIGO

Algumas baterias reserva contêm uma pequena quantidade de níquel e cádmio. Não desmonte uma bateria reserva, recarregue-a, jogue-a no fogo ou na água, ou deixe-a entrar em curto-circuito. Descarte a bateria conforme requerido pelas leis ou regulamentos locais. Use somente a bateria nas partes listadas apropriadas. O uso de uma bateria incorreta pode resultar em combustão ou explosão da bateria.



PERIGO

O pacote da bateria contém uma pequena quantidade de níquel. Não o desmonte, jogue-o no fogo ou na água, ou deixe-o entrar em curto-circuito. Descarte o pacote da bateria conforme requerido pelas leis ou regulamentos locais. Use somente a bateria nas partes listadas apropriadas ao substituir o pacote da bateria. O uso de uma bateria incorreta pode resultar em combustão ou explosão da bateria.



PERIGO

A bateria de lítio pode causar incêndio, explosão ou graves queimaduras. Não a recarregue, remova seu conector polarizado, desmonte-a, aqueça-a acima de 100°C (212°F), incinere-a, ou exponha o conteúdo de sua célula à água. Descarte a bateria conforme requerido pelas leis ou regulamentos locais. Use somente a bateria nas partes listadas apropriadas. O uso de uma bateria incorreta pode resultar em combustão ou explosão da bateria.



PERIGO

Se o LCD quebrar e o fluido de dentro dele entrar em contato com seus olhos ou com suas mãos, lave as áreas afetadas imediatamente com água durante pelo menos 15 minutos. Procure cuidados médicos se algum sintoma causado pelo fluido surgir após a lavagem.



PERIGO

Para evitar choque elétrico, não remova a capa plástica que protege a parte inferior da placa inversora.



PERIGO

Embora as principais baterias possuam baixa voltagem, uma bateria em curto-circuito ou aterrada pode produzir corrente o bastante para queimar materiais de pessoal ou inflamáveis.



PERIGO

A menos que uma hot swap seja permitida para a FRU que está sendo substituída, faça o seguinte antes de removê-la: desligue o computador, desconecte todos os cabos de energia das tomadas, remova o pacote de baterias e desconecte quaisquer cabos de interconexão.



DANGER

Avant de remettre l'ordinateur sous tension après remplacement d'une unité en clientèle, vérifiez que tous les ressorts, vis et autres pièces sont bien en place et bien fixées. Pour ce faire, secouez l'unité et assurez-vous qu'aucun bruit suspect ne se produit. Des pièces métalliques ou des copeaux de métal pourraient causer un court-circuit.



DANGER

Certaines batteries de secours contiennent du nickel et du cadmium. Ne les démontez pas, ne les rechargez pas, ne les exposez ni au feu ni à l'eau. Ne les mettez pas en court-circuit. Pour les mettre au rebut, conformez-vous à la réglementation en vigueur. Lorsque vous remplacez la pile de sauvegarde ou celle de l'horloge temps réel, veillez à n'utiliser que les modèles cités dans la liste de pièces détachées adéquate. Une batterie ou une pile inappropriée risque de prendre feu ou d'exploser.



DANGER

La batterie contient du nickel. Ne la démontez pas, ne l'exposez ni au feu ni à l'eau. Ne la mettez pas en court-circuit. Pour la mettre au rebut, conformez-vous à la réglementation en vigueur. Lorsque vous remplacez la batterie, veillez à n'utiliser que les modèles cités dans la liste de pièces détachées adéquate. En effet, une batterie inappropriée risque de prendre feu ou d'exploser.



DANGER

La pile de sauvegarde contient du lithium. Elle présente des risques d'incendie, d'explosion ou de brûlures graves. Ne la rechargez pas, ne retirez pas son connecteur polarisé et ne la démontez pas. Ne l'exposez pas à une température supérieure à 100°C, ne la faites pas brûler et n'en exposez pas le contenu à l'eau. Mettez la pile au rebut conformément à la réglementation en vigueur. Une pile inappropriée risque de prendre feu ou d'exploser.



DANGER

Si le panneau d'affichage à cristaux liquides se brise et que vous recevez dans les yeux ou sur les mains une partie du fluide, rincez-les abondamment pendant au moins quinze minutes. Consultez un médecin si des symptômes persistent après le lavage.



DANGER

Afin d'éviter tout risque de choc électrique, ne retirez pas le cache en plastique protégeant la partie inférieure de la carte d'alimentation.



DANGER

Bien que le voltage des batteries principales soit peu élevé, le court-circuit ou la mise à la masse d'une batterie peut produire suffisamment de courant pour brûler des matériaux combustibles ou causer des brûlures corporelles graves.



DANGER

Si le remplacement à chaud n'est pas autorisé pour l'unité remplaçable sur site que vous remplacez, procédez comme suit avant de retirer l'unité : mettez l'ordinateur hors tension, débranchez tous les cordons d'alimentation des prises de courant, retirez le bloc de batterie et déconnectez tous les câbles d'interconnexion.



VORSICHT

Bevor nach einem FRU-Austausch der Computer wieder angeschlossen wird, muß sichergestellt werden, daß keine Schrauben, Federn oder andere Kleinteile fehlen oder im Gehäuse vergessen wurden. Der Computer muß geschüttelt und auf Klappergeräusche geprüft werden. Metallteile oder-splitter können Kurzschlüsse erzeugen.



VORSICHT

Die Bereitschaftsbatterie, die sich unter dem Diskettenlaufwerk befindet, kann geringe Mengen Nickel und Cadmium enthalten. Sie darf nur durch die Verkaufsstelle oder den IBM Kundendienst ausgetauscht werden. Sie darf nicht zerlegt, wiederaufgeladen, kurzgeschlossen, oder Feuer oder Wasser ausgesetzt werden. Die Batterie kann schwere Verbrennungen oder Verätzungen verursachen. Bei der Entsorgung die örtlichen Bestimmungen für Sondermüll beachten. Beim Ersetzen der Bereitschafts- oder Systembatterie nur Batterien des Typs verwenden, der in der Ersatzteilliste aufgeführt ist. Der Einsatz falscher Batterien kann zu Entzündung oder Explosion führen.



VORSICHT

Akkus enthalten geringe Mengen von Nickel. Sie dürfen nicht zerlegt, wiederaufgeladen, kurzgeschlossen, oder Feuer oder Wasser ausgesetzt werden. Bei der Entsorgung die örtlichen Bestimmungen für Sondermüll beachten. Beim Ersetzen der Batterie nur Batterien des Typs verwenden, der in der Ersatzteilliste aufgeführt ist. Der Einsatz falscher Batterien kann zu Entzündung oder Explosion führen.



VORSICHT

Die Systembatterie ist eine Lithiumbatterie. Sie kann sich entzünden, explodieren oder schwere Verbrennungen hervorrufen. Batterien dieses Typs dürfen nicht aufgeladen, zerlegt, über 100°C erhitzt oder verbrannt werden. Auch darf ihr Inhalt nicht mit Wasser in Verbindung gebracht oder der zur richtigen Polung angebrachte Verbindungsstecker entfernt werden. Bei der Entsorgung die örtlichen Bestimmungen für Sondermüll beachten. Beim Ersetzen der Batterie nur Batterien des Typs verwenden, der in der Ersatzteilliste aufgeführt ist. Der Einsatz falscher Batterien kann zu Entzündung oder Explosion führen.



VORSICHT

Die Leuchtstoffröhre im LCD-Bildschirm enthält Quecksilber. Bei der Entsorgung die örtlichen Bestimmungen für Sondermüll beachten. Der LCD-Bildschirm besteht aus Glas und kann zerbrechen, wenn er unsachgemäß behandelt wird oder der Computer auf den Boden fällt. Wenn der Bildschirm beschädigt ist und die darin befindliche Flüssigkeit in Kontakt mit Haut und Augen gerät, sollten die betroffenen Stellen mindestens 15 Minuten mit Wasser abgespült und bei Beschwerden anschließend ein Arzt aufgesucht werden.



VORSICHT

Aus Sicherheitsgründen die Kunststoffabdeckung, die den unteren Teil der Spannungswandlerplatine umgibt, nicht entfernen.



VORSICHT

Obwohl Hauptbatterien eine niedrige Spannung haben, können sie doch bei Kurzschluß oder Erdung genug Strom abgeben, um brennbare Materialien zu entzünden oder Verletzungen bei Personen hervorzurufen.



VORSICHT

Wenn ein Austausch der FRU bei laufendem Betrieb nicht erlaubt ist, gehen Sie beim Austausch der FRU wie folgt vor: Schalten Sie den Computer aus, ziehen Sie alle Netzkabel von den Netzsteckdosen ab, entfernen Sie den Akku und ziehen Sie alle miteinander verbundenen Kabel ab.



לפני הפעלת המחשב לאחר החלפת FRU יש לוודא שכל חברגים, חקפייצים, וחלקים קטנים אחרים נמצאים במקומם ואינם חופשיים לזוז בתוך המחשב. כדי לוודא זאת, יש לטלטל את המחשב ולחקשיב לגילוי קולות שקשוק. חלקי או שבי מותכת עלולים לגרום לקצרים חשמליים.



סכנה

סוללות המתנה מסיימות מכילות כמויות קטנות של ניקל וקדמיום. אין לפרק סוללת המתנה, לטעון אותה מחדש, להשליך אותה לאש או למים או לקצר אותה. יש לסלק את הסוללה כנדרש על ידי התקנות והחוקים המקומיים. יש להשתמש רק בסוללה המופיעה ברשימת החלקים המתאימה. שימוש בסוללה לא מתאימה עלול לגרום להצתה או התפוצצות של הסוללה.



סכנה

מארז הסוללה מכיל כמויות קטנות של ניקל וקדמיום. אין לפרק את מארז הסוללה, להשליך אותו לאש או למים או לקצר אותו. יש לסלק את מארז הסוללה כנדרש על ידי התקנות והחוקים המקומיים. יש להשתמש רק בסוללה המופיעה ברשימת החלקים המתאימה בזמן החלפת מארז הסוללה. שימוש בסוללה לא מתאימה עלול לגרום להצתה או התפוצצות של הסוללה.



סכנה

סוללת הליתיום עלולה לגרום לשריפה, להתפוצצות או לכוויות קשות. אין לטעון אותה מחדש, לסלק את המחבר המקוטב שלה, לפרק אותה או לחמם אותה לטמפרטורה העולה על 100 מעלות צלזיוס. אין לשרוף את הסוללה ואין לחשוף את תוכן התא למים. יש לסלק את הסוללה כנדרש בתקנות ובחוקים המקומיים. יש להשתמש רק בסוללה המופיעה ברשימת החלקים המתאימים. שימוש בסוללה אחרת עלול לגרום לסכנת שריפה או התפוצצות.



סכנה

אם מסך הנגיש הנוזלי (LCD) נשבר והנוזל מתוך המסך בא במגע עם עיניכם או ידיכם, שטפו את האזורים הנגועים מיד במים במשך 15 דקות לפחות. פנו לקבלת עזרה רפואית אם תסמינים הנובעים מחמגע עם הנוזל נמשכים לאחר הטיפול.



סכנה

כדי למנוע התחשמלות, אין להסיר את מכסה הפלסטיק המגן על חלקו התחתון של הכרטיס החפץ.



סכנה

אף שהסוללות הראשיות הן בעלות מתח נמוך, סוללה מקוצרת או מוארכת עלולה להפיק זרם מספיק לגרימת כוויות או להצתת חומרים דליקים.



סכנה

אלא אם כן מותרת 'החלפה ממהי' של ה-FRU המוחלף, פעלו כדלהלן לפני הסרתו: כבו את המחשב, נתקו את כל כבלי החשמל מהשקעים, הוציאו את מארז הסוללות ונתקו את כל הכבלים המחוברים.



危険

FRU の交換後、ThinkPad の電源を入れる前に、ねじ、バネ、その他の小さな部品がすべて正しい位置にあり、また ThinkPad の内部で緩んでいないことを確認してください。

これを確認するには、ThinkPad を振って、カチャカチャと音がしないか確かめます。金属部品や金属破片はショートの原因になることがあります。



危険

予備バッテリーの中には少量のニッケルとカドミウムが含まれているものがあります。したがって、予備バッテリーの分解、再充電、火または水の中への投棄、またはショートさせることは決して行わないでください。バッテリーを廃棄する場合は地方自治体の条例に従ってください。適切なパーツ・リストにあるバッテリーだけを使用してください。誤ったバッテリーを使用すると、バッテリーが発火したり、爆発したりすることがあります。



危険

バッテリー・パックには少量のニッケルが含まれています。バッテリー・パックを分解したり、火または水の中に投げ込んだり、ショートさせないでください。バッテリー・パックの廃棄にあたっては、地方自治体の条例または規則に従ってください。バッテリー・パックを交換するときは、適切なパーツ・リストにあるバッテリーだけを使用してください。誤ったバッテリーを使用すると、バッテリーが発火したり、爆発したりすることがあります。



危険

リチウム・バッテリーは、火災、爆発、または重症のやけどを引き起こすことがあります。バックアップ・バッテリーの充電、その極性コネクターの取り外し、バッテリー本体の分解、100 °C (212 °F) 以上への加熱、焼却、電池の中身を水に浸すことはしないでください。バッテリーを廃棄する場合は地方自治体の条例に従ってください。適切なパーツ・リストにあるバッテリーだけを使用してください。誤ったバッテリーを使用すると、バッテリーが発火したり、爆発したりすることがあります。



危険

LCD が破損し、LCD の中の液体が目に入ったり、手に触れたりした場合は、液体が触れた部分を少なくとも 15 分間洗い流してください。洗い流した後に、液体によって何らかの症状が現れた場合は、医師の治療を受けてください。



危険

感電を防ぐため、インバーター・カードの下部を保護しているプラスチック・カバーを外さないでください。



危険

메인·배터리의電圧は低くても、ショートしたり、接地したバッテリーが、作業者にやけどを負わせたり、可燃物を燃やすだけの電流を発生させる場合があります。



危険

交換しようとしている FRU がホット・スワップに対応していない場合、それを取り外す前に、コンピューターの電源をオフにし、すべての電源コードをコンセントから抜き、バッテリー・パックを取り外して、相互接続しているケーブルをすべて切り離してください。



위험

FRU를 교체하고 나서 컴퓨터 전원을 켜기 전에 모든 나사, 스프링 및 기타 작은 부품들이 올바른 위치에 있는지, 컴퓨터 내부에 단단하게 연결되어 있는지 확인하십시오. 컴퓨터를 흔들며 달걀거리는 소리가 나지 않는지 확인하십시오. 금속 부품 또는 금속 조각은 누전을 일으킬 수 있습니다.



위험

일부 보조 배터리에는 소량의 니켈 및 카드뮴이 포함되어 있습니다. 보조 배터리를 분해하거나, 다시 충전하거나, 불 또는 물에 던지거나, 단락시키지 마십시오. 배터리 팩을 폐기할 때에는 해당 지역의 법률 규정을 따르십시오. 배터리 팩을 교체할 때에는 올바른 배터리만 사용하십시오. 올바르지 않은 배터리를 사용하면 배터리가 발화되거나 폭발할 수 있습니다.



위험

배터리 팩에는 소량의 니켈이 포함되어 있습니다. 배터리 팩을 분해하거나, 불 또는 물에 던지거나, 단락시키지 마십시오. 배터리 팩을 폐기할 때에는 해당 지역의 법률 규정을 따르십시오. 배터리 팩을 교체할 때에는 올바른 배터리만 사용하십시오. 올바르지 않은 배터리를 사용하면 배터리가 발화되거나 폭발할 수 있습니다.



위험

리튬 배터리는 화재, 폭발 또는 심각한 화상을 일으킬 수 있습니다. 리튬 배터리를 다시 충전하거나, 극성 커넥터를 제거하거나, 분해하거나, 100C(212F) 이상으로 가열하거나, 소각하거나, 전지 내용물을 물에 노출시키지 마십시오. 배터리를 폐기할 때에는 해당 지역을 법률 규정을 따르십시오. 올바른 배터리만 사용하십시오. 올바르지 않은 배터리를 사용하면 배터리가 발화되거나 폭발할 수 있습니다.



위험

LCD가 파손되어 LCD 내부의 액체가 눈에 들어가거나 손에 묻으면 즉시 깨끗한 물로 15분 이상 닦아 내십시오. 씻은 후에 조금이라도 이상을 느낀다면 즉시 병원에 가서 의사의 진찰을 받아야 합니다.



전기적 위험을 방지하려면 인버터 카드의 아래 부분을 보호하는 플라스틱 덮개를 제거하지 마십시오.



기본 배터리의 전압은 낮지만, 단락되거나 접지된 배터리는 화상을 입히기에 충분한 전류와 가연성 물질을 발생시킬 수 있습니다.



FRU 교체 시 Hot Swap이 지원되지 않는 경우, FRU를 제거하기 전에 컴퓨터의 전원을 끄고, 전기 콘센트에서 전원 코드를 분리하고, 배터리를 제거한 후, 연결된 모든 케이블을 분리하십시오.



Antes de encender el sistema después de sustituir una FRU, compruebe que todos los tornillos, muelles y demás piezas pequeñas se encuentran en su sitio y no se encuentran sueltas dentro del sistema. Compruébelo agitando el sistema y escuchando los posibles ruidos que provocarían. Las piezas metálicas pueden causar cortocircuitos eléctricos.



Algunas baterías de reserva contienen una pequeña cantidad de níquel y cadmio. No las desmonte, ni recargue, ni las eche al fuego o al agua ni las cortocircuite. Deséchelas tal como dispone la normativa local. Utilice sólo baterías que se encuentren en la lista de piezas. La utilización de una batería no apropiada puede provocar la ignición o explosión de la misma.



Las baterías contienen pequeñas cantidades de níquel. No las desmonte, ni recargue, ni las eche al fuego o al agua ni las cortocircuite. Deséchelas tal como dispone la normativa local. Utilice sólo baterías que se encuentren en la lista de piezas al sustituir la batería. La utilización de una batería no apropiada puede provocar la ignición o explosión de la misma.



La batería de repuesto es una batería de litio y puede provocar incendios, explosiones o quemaduras graves. No la recargue, ni quite el conector polarizado, ni la desmonte, ni caliente por encima de los 100°C (212°F), ni la incinere ni exponga el contenido de sus celdas al agua. Deséchela tal como dispone la normativa local.

 PELIGRO

Si la LCD se rompe y el fluido de su interior entra en contacto con sus ojos o sus manos, lave inmediatamente las áreas afectadas con agua durante 15 minutos como mínimo. Obtenga atención médica si se presenta algún síntoma del fluido después de lavarse.

 PELIGRO

Para evitar descargas, no quite la cubierta de plástico que rodea la parte baja de la tarjeta invertida.

 PELIGRO

Aunque las baterías principales tienen un voltaje bajo, una batería cortocircuitada o con contacto a tierra puede producir la corriente suficiente como para quemar material combustible o provocar quemaduras en el personal.

 PELIGRO

Salvo que se permita el intercambio en caliente para la unidad sustituible localmente, realice lo siguiente antes de extraerla: apague el sistema, desconecte todos los cables de alimentación de las tomas de alimentación eléctrica, extraiga la batería y desconecte los cables de interconexión.

 危險

完成 FRU 更換之後，在開啟電腦的電源之前，請確定所有螺絲、彈簧及其他小零件都已歸位，沒有遺留在電腦內部。
若要確認這一點，請搖晃電腦，聽聽看是否有卡嗒的聲響。
金屬零件或儀錶的火花會造成電線短路。

 危險

部分備用電池含有微量的鎳和鎘。請勿拆開備用電池、再充電、丟入火或水中，或使其形成短路。請按照當地法令或規定來棄置電池。
僅限使用零件清單中的電池。使用不適當的電池會導致電池起火或爆炸。

 危險

電池套件含有微量的鎳。請勿拆開電池套件、丟入火或水中，或使其形成短路。
請按照當地法令或規定來棄置電池套件。

更換電池套件時，僅限使用零件清單中的電池。使用不適當的電池會導致電池
起火或爆炸。



鋰電池會導致起火、爆炸或嚴重燒傷。請勿再充電、拔除其電極接頭、拆開、
加熱超過 100°C (212°F)、焚燒，或讓電池組成物浸到水。請按照當地法
令或規定來棄置電池。
僅限使用零件清單中的電池。使用不適當的電池會導致電池起火或爆炸。



如果 LCD 破裂導致 LCD 流出的液體沾到您的眼睛或手，請立即以清水沖洗沾
染部位至少 15 分鐘。如果在清洗後出現該液體所造成的任何症狀，請就醫治
療。



為避免電擊，請勿拆下轉換卡下面的塑膠護蓋。



雖然主電池的電壓很低，但短路或接地電池所產生的電流，仍足以使人燒傷或
使可燃物質起火。



除非 FRU 允許以熱抽換來替換，否則請依下列方式將其移除：將電腦關機，拔除插
座上所有電源線，移除電池包，並拔開任何交互連接的線材。

Laser compliance statement (multilingual translations)

The laser compliance statements in this section are provided in the following languages:

- English
- Arabic
- Brazilian Portuguese
- French
- German
- Hebrew
- Japanese
- Korean
- Spanish
- Traditional Chinese



CAUTION:

When laser products (such as CD-ROMs, DVD drives, fiber optic devices, or transmitters) are installed, note the following:

- Do not remove the covers. Removing the covers of the laser product could result in exposure to hazardous laser radiation. There are no serviceable parts inside the device.
- Use of controls or adjustments or performance of procedures other than those specified herein might result in hazardous radiation exposure.



DANGER

Some laser products contain an embedded Class 3A or Class 3B laser diode. Note the following.

Laser radiation when open. Do not stare into the beam, do not view directly with optical instruments, and avoid direct exposure to the beam.



تحذير:

عند تثبيت منتجات الليزر (مثل أقراص CD-ROM أو محركات تشغيل أقراص DVD أو أجهزة الألياف البصرية أو النواقل)، لاحظ ما يلي:

- لا تقم بنزع الغطاء. قد ينتج عن نزع غطاء منتج ليزر التعرض لأشعة ليزر في منتهى الخطورة. لا توجد أجزاء يمكن صيانتها داخل الجهاز.
- قد ينتج عن استخدام مفاتيح أو تنفيذ عمليات ضبط أو إجراءات بطريقة مختلفة عما هو محدد هنا التعرض لأشعة ليزر في منتهى الخطورة.



خطر

تحتوي بعض منتجات الليزر على صمام ثنائي ليزري مضمن من Class 3A أو Class 3B. لاحظ ما يلي. توجد أشعة ليزر عند الفتح. لا تنظر للشعاع ولا تنظر بطريقة مباشرة باستخدام أدوات ضوئية وتجنب التعرض المباشر للشعاع.

**CUIDADO:**

Quando produtos a laser (como CD-ROMs, unidades de DVD, dispositivos de fibra ótica ou transmissores) estão instalados, observe o seguinte:

- Não remova as tampas. A remoção das tampas do produto a laser pode resultar em exposição prejudicial à radiação de laser. Não há peças que permitam manutenção no interior do dispositivo.
- A utilização de controles ou ajustes ou a execução de procedimentos diferentes daqueles especificados aqui pode resultar em exposição perigosa à radiação.

**PERIGO**

Algumas produtos a laser contêm um diodo de laser Classe 3A ou Classe 3B integrado. Observe o seguinte:

Radiação a laser quando aberta. Não olhe diretamente para o feixe a olho nu ou com instrumentos óticos e evite exposição direta ao feixe.

**ATTENTION :**

Si des produits laser (tels que des unités de CD, DVD, à fibre optique ou des émetteurs) sont installés, lisez les informations suivantes :

- Ne retirez pas les carter. En ouvrant le produit laser, vous vous exposez au rayonnement dangereux du laser. Aucune pièce de l'unité n'est réparable.
- Pour éviter tout risque d'exposition au rayon laser, respectez les consignes de réglage et d'utilisation des commandes, ainsi que les procédures décrites dans le présent manuel.

**DANGER**

Certains produits à laser contiennent une diode à laser intégrée de classe 3A ou 3B. Prenez connaissance des informations suivantes.

Rayonnement laser lorsque le carter est ouvert. Evitez toute exposition directe au rayon laser. Evitez de regarder fixement le faisceau ou de l'observer à l'aide d'instruments optiques.



Vorsicht:

Bei der Installation von Lasergeräten (wie CD-ROM-Laufwerken, DVD-Laufwerken, Einheiten mit Lichtwellenleitertechnik oder Sendern) Folgendes beachten:

- Die Abdeckungen nicht entfernen. Durch Entfernen der Abdeckungen des Lasergeräts können gefährliche Laserstrahlungen freigesetzt werden. Das Gerät enthält keine zu wartenden Teile.
- Werden Steuerelemente, Einstellungen oder Durchführungen von Prozeduren anders als hier angegeben verwendet, kann gefährliche Laserstrahlung auftreten.



Gefahr

Einige Lasergeräte enthalten eine Laserdiode der Klasse 3A oder 3B. Beachten Sie Folgendes:

Laserstrahlung bei geöffneter Verkleidung. Nicht in den Strahl blicken. Keine Lupen oder Spiegel verwenden. Strahlungsbereich meiden.



זהירות:

כאשר מוצרי לייזר (כגון תקליטורים, כונני DVD, התקני סיבים אופטיים או משדרים) מותקנים, שימו לב להנחיות

הבאות:

- אל תסירו את הכיסויים. הסרת הכיסויים של מוצר הלייזר עלולה לגרום לחשיפה מסוכנת לקרינת לייזר. ההתקן אינם כוללים רכיבים להחלפה עצמית.
- שימוש בבקורות ובהתאמות שלא צוינו או ביצוע תהליכים שלא צוינו, יכולים לגרום לחשיפה מסוכנת לקרינה.



סכנה

כמה ממוצרי הלייזר מכילים דיודת לייזר מובנית Class 3A או Class 3B. שימו לב לדברים שלהלן. קיימת פליטת קרני לייזר כאשר המוצר פתוח. אל תביטו ישירות אל הקרן, אל תביטו אל הקרן ישירות דרך אמצעים אופטיים, והימנעו מחשיפה ישירה לקרן.



警告:

レーザー製品 (CD-ROM、DVD ドライブ、光ファイバー装置、または送信機など) を取り付ける場合には、以下のことに注意してください。

- カバーを外さないこと。カバーを取り外すと有害なレーザー光を浴びることがあります。この装置の内部には保守が可能な部品はありません。
- 本書で指定された内容以外の、お客様による整備、調整、または手順を行った場合、レーザー放射の危険があります。



危険

一部のレーザー製品には、クラス 3A またはクラス 3B のレーザー・ダイオードが組み込まれています。次の点に注意してください。

開けるとレーザー光が放射されます。光線を見つめたり、光学機械を使って直接見たり、光線を直接浴びることは避けてください。



경고:

레이저 제품 (CD-ROM, DVD 드라이브, 광섬유 장치 또는 송신기)이 설치되어 있는 경우, 다음과 같은 취급 주의사항을 참고하십시오.

- 덮개를 제거하지 마십시오. 레이저 제품의 덮개를 제거하면 유해한 레이저 복사에 노출될 위험이 있습니다. 장치 내부에는 사용자가 수리할 수 있는 부분이 없습니다.
- 본 내용에서 설명한 이외의 방법으로 드라이브를 조정하거나 제어 또는 작동하는 경우, 해로운 레이저 복사에 노출될 수 있습니다.



위험

일부 레이저 제품은 임베디드 클래스 3A 또는 클래스 3B 레이저 다이오드가 포함되어 있습니다. 다음 주의사항을 유의하십시오.

드라이브의 덮개를 열면 전자파가 발생합니다. 광선 또는 광 장치를 직접 보거나 광선에 노출되지 않도록 주의하십시오.



PRECAUCIÓN:

Cuando haya instalados productos láser (por ejemplo, unidades de CD-ROM, unidades de DVD, dispositivos de fibra óptica o transmisores), tenga en cuenta lo siguiente:

- No extraiga las cubiertas. La extracción de las cubiertas del producto láser podría producir una exposición a radiación láser peligrosa. No hay ninguna pieza dentro del dispositivo que pueda reparar.
- La utilización de controles, ajustes o la realización de procedimientos diferentes a los especificados puede dar como resultado una exposición peligrosa a radiaciones.



PELIGRO

Algunos productos láser contienen un diodo láser de Clase 3A o Clase 3B incorporado. Tenga en cuenta lo siguiente.

Emite radiación láser cuando está abierto. No fije la vista en el rayo, no lo mire directamente con instrumentos ópticos y evite la exposición directa al rayo.



警告：

安裝雷射產品（如 CD-ROM、DVD 光碟機、光纖裝置或轉送器）時，請注意下列事項：

- 請勿卸下外蓋。卸下雷射產品的外蓋可能導致曝露於危險的雷射輻射。裝置內沒有可維修的零件。
- 若不遵守本文規定的控制、調整或操作程序，可能會導致危險的輻射外洩。



危險

某些雷射產品包含內嵌式 3A 類或 3B 類雷射二極體。這類光碟機的使用者應注意下列聲明。

在開啟光碟機時，會有雷射輻射。請勿直視光束或以光學儀器直接觀看光束，並避免直接暴露在光束中。

Chapter 2. Important service information

This chapter introduces following important service information that applies to all machine types supported by this manual:

- “Strategy for replacing FRUs” on page 23
 - “Strategy for replacing a hard disk drive, a solid-state drive, or an mSATA solid-state drive” on page 23
 - “Important notice for replacing a system board” on page 24
 - “How to use error message” on page 24
- “Strategy for replacing FRUs for CTO, CMV, and GAV” on page 24
 - “Product definition” on page 24
 - “FRU identification for CTO, CMV, and GAV products” on page 25

Important:

- If the computer is equipped with both a hard disk drive and an mSATA solid-state drive, do not use the mSATA solid-state drive as a bootable device. The mSATA solid-state drive is designed and developed for “cache” function purpose only.
- Advise customers to contact the Lenovo® Customer Support Center if they need any assistance in obtaining or installing any software fixes, drivers, and UEFI BIOS downloads. Telephone numbers for Lenovo Support are available at: <http://www.lenovo.com/support/phone>
- System Disassembly/Reassembly videos that show the FRU removals or replacements for the Lenovo authorized service technicians are available in the following support site: <http://www.lenovoservicetraining.com/ion/>

Strategy for replacing FRUs

Before replacing parts:

Make sure that all software fixes, drivers, and UEFI BIOS downloads are installed before replacing any FRUs listed in this manual.

After a system board is replaced, ensure that the latest UEFI BIOS is loaded to the system board before completing the service action.

To download software fixes, drivers, and UEFI BIOS, go to <http://www.lenovo.com/ThinkPadDrivers> and follow the instructions on the screen.

Use the following strategy to prevent unnecessary expense for replacing and servicing FRUs:

- If you are instructed to replace a FRU but the replacement does not correct the problem, reinstall the original FRU before you continue.
- Some computers have both a processor board and a system board. If you are instructed to replace either the processor board or the system board, and replacing one of them does not correct the problem, reinstall that board, and then replace the other one.
- If an adapter or a device consists of more than one FRU, any of the FRUs may be the cause of the error. Before replacing the adapter or device, remove the FRUs, one by one, to see if the symptoms change. Replace only the FRU that changed the symptoms.

Strategy for replacing a hard disk drive, a solid-state drive, or an mSATA solid-state drive

Always try to run a low-level format operation before replacing a hard disk drive or a solid-state drive. This will cause all customer data on the drive to be lost. Be sure that the customer has a current backup of the data before you perform this task.

Attention: The drive startup sequence in the computer you are servicing might have been changed. Be extremely careful during write operations such as copying, saving, or formatting. If you select an incorrect drive, data or programs can be overwritten.

If the computer is shipped with both an mSATA solid-state drive and a hard disk drive, the mSATA solid-state drive is used for the “cache” function and to support the Intel® Rapid Start Technology. We recommend that users do not replace the mSATA solid-state drive by themselves. Otherwise, the “cache” function will not work and the Intel Rapid Start Technology cannot be used any more.

Attention: Ensure that you partition the mSATA solid-state drive after installing it on the computer you are servicing. Otherwise, the mSATA solid-state drive will not function correctly. For instructions on how to partition an mSATA solid-state drive, go to <http://www.lenovo.com/support/msata-fru>.

Important notice for replacing a system board

Some components mounted on a system board are very sensitive. Improper handling of a system board can cause damage to those components, and may cause a system malfunction.

Attention: When handling a system board:

- Do not drop a system board or apply any excessive force to it.
- Avoid rough handling of any kind.
- Avoid bending a system board and hard pushing to prevent cracking at each BGA (Ball Grid Array) chipset.

How to use error message

Use the error codes displayed on the screen to diagnose failures. If more than one error code is displayed, begin the diagnosis with the first error code. Whatever causes the first error code may also cause false error codes. If no error code is displayed, see whether the error symptom is listed in the Symptom-to-FRU Index for the computer you are servicing.

Strategy for replacing FRUs for CTO, CMV, and GAV

Product definition

Dynamic Configure To Order (CTO)

This provides the ability for a customer to configure a Lenovo solution from an eSite, and have this configuration sent to fulfillment, where it is built and shipped directly to the customer. The machine label, Product Entitlement Warehouse (PEW), and eSupport will load these products as the 4-digit MT and 3-digit model, where model = “CTO” (Example: 1829-CTO).

Custom Model Variant (CMV)

This is a unique configuration that has been negotiated between Lenovo and the customer. A unique 4-digit MT and 3-digit model is provided to the customer to place orders (Example: 1829-W15). A CMV is a special bid offering. Therefore, it is not generally announced.

- The MTM portion of the machine label is the 4-digit MT and 3-digit model, where model = “CTO” (Example: 1829-CTO). The PRODUCT ID portion of the machine label is the 4-digit MT and 3-digit CMV model (Example: 1829-W15).
- The PEW record is the 4-digit MT and 3-digit model, where model = “CTO” (Example: 1829-CTO).
- eSupport will show both the CTO and CMV machine type models (Example: 1829-CTO and 1829-W15 will be found on the eSupport site.)

General Announce Variant (GAV)

This is a standard model (fixed configuration). GAVs are announced and offered to all customers. The MTM portion of the machine label is a 4-digit MT and 3-digit model, where model = a “fixed part number”, not “CTO” (Example: 1829-F1U). Also, PEW and eSupport will list these products under the same fixed model number.

FRU identification for CTO, CMV, and GAV products

There are three information resources to identify which FRUs are used to support CTO, CMV, and GAV products. These sources are PEW and eSupport.

Using PEW

- **PEW** is the primary source for identifying FRU part numbers and FRU descriptions for the key commodities for CTO, CMV and GAV products at a MT - serial number level. An example of key commodities are hard disk drives, system boards, microprocessors, Liquid Crystal Displays (LCDs), and memory.
- Remember, all CTO and CMV products are loaded in PEW under the 4-digit MT and 3-digit model, where model = “CTO” (Example: 1829-CTO). GAVs are loaded in PEW under the 4-digit MT and 3-digit model, where model = a “fixed part number”, not “CTO” (Example: 1829-F1U).
- PEW can be accessed at the following Web site:
<http://www.lenovo.com/support/site.wss/document.do?Indocid=LOOK-WARNTY>
Select Warranty lookup. Input the MT and the Serial number and the list of key commodities will be returned in the PEW record under COMPONENT INFORMATION.

Using eSupport

For Key Commodities (Examples - hard disk drive, system board, microprocessor, LCD, and memory)

- eSupport can be used to view the list of key commodities built in a particular machine serial (this is the same record found in PEW).
- eSupport can be accessed at the following Web site:
<http://www.lenovo.com/support>
- To view the key commodities, do the following:
 1. Click **Warranty**.
 2. Click **Check Warranty Status**.
 3. On the Warranty Status Lookup page, click **Parts Lookup**.
 4. Type your machine type and serial number, and then click **Submit**. The key commodities will be displayed.

For the Remaining FRUs (the complete list of FRUs at the MT Model level)

- eSupport can be used to view the complete list of FRUs for a machine type and model.
- eSupport can be accessed at the following Web site:
<http://www.lenovo.com/support>
- To view the complete list of FRUs, do the following:
 1. Click **Product & Parts Detail** and then follow the instructions on the screen to reach the Product and Parts Details page.
 2. Click the **Parts Detail** tab to view the list of service parts.

Chapter 3. General checkout

This chapter introduces following information:

- “What to do first” on page 27
- “Checkout guide” on page 28
 - “Lenovo Solution Center” on page 28
 - “Quick test programs” on page 28
 - “UEFI diagnostic program” on page 29
 - “Bootable diagnostic programs” on page 29
- “Power system checkout” on page 30

Before you go to the checkout guide, be sure to read the following important notes.

Important notes:

- **Only certified trained personnel should service the computer.**
- **Before replacing any FRU, read the entire page on removing and replacing FRUs.**
- **When you replace FRUs, it is recommended use new nylon-coated screws.**
- **Be extremely careful during such write operations as copying, saving, or formatting.** Drives in the computer that you are servicing sequence might have been altered. If you select an incorrect drive, data or programs might be overwritten.
- **Replace a FRU only with another FRU of the correct model.** When you replace a FRU, make sure that the model of the machine and the FRU part number are correct by referring to the web site: <http://www.lenovo.com/serviceparts-lookup>
- **A FRU should not be replaced because of a single, unreproducible failure.** Single failures can occur for a variety of reasons that have nothing to do with a hardware defect, such as cosmic radiation, electrostatic discharge, or software errors. Consider replacing a FRU only when a problem recurs. If you suspect that a FRU is defective, clear the error log and run the test again. If the error does not recur, do not replace the FRU.
- **Be careful not to replace a nondefective FRU.**

What to do first

When you return a FRU, you must include the following information in the parts exchange form or parts return form that you attach to it:

1. Name and phone number of service technician
2. Date of service
3. Date on which the machine failed
4. Date of purchase
5. Failure symptoms, error codes appearing on the display, and beep symptoms
6. Procedure index and page number in which the failing FRU was detected
7. Failing FRU name and part number
8. Machine type, model number, and serial number
9. Customer's name and address

Note: During the warranty period, the customer may be responsible for repair costs if the computer damage was caused by misuse, accident, modification, unsuitable physical or operating environment, or improper maintenance by the customer. Following is a list of some common items that are not covered under warranty and some symptoms that might indicate that the system was subjected to stress beyond normal use.

Before checking problems with the computer, determine whether the damage is covered under the warranty by referring to the following list:

The following are not covered under warranty:

- LCD panel cracked from the application of excessive force or from being dropped
- Scratched (cosmetic) parts
- Distortion, deformation, or discoloration of the cosmetic parts
- Plastic parts, latches, pins, or connectors that have been cracked or broken by excessive force
- Damage caused by liquid spilled into the system
- Damage caused by the improper insertion of a PC card or the installation of an incompatible card
- Improper disc insertion or use of an optical drive
- Fuses blown by attachment of a nonsupported device
- Forgotten computer password (making the computer unusable)
- Sticky keys caused by spilling a liquid onto the keyboard
- Use of an incorrect ac power adapter on laptop products

The following symptoms might indicate damage caused by nonwarranted activities:

- Missing parts might be a symptom of unauthorized service or modification.
- If the spindle of a hard disk drive becomes noisy, it may have been subjected to excessive force, or dropped.

Checkout guide

Use the following procedures as a guide in identifying and correcting problems with the ThinkPad notebook computers.

Note: The diagnostic tests are intended to test only ThinkPad products. The use of non-ThinkPad products, prototype cards, or modified options can lead to false indications of errors and invalid system responses.

1. Identify the failing symptoms in as much detail as possible.
2. Verify the symptoms. Try to re-create the failure by running the diagnostic test or by repeating the operation.

Lenovo Solution Center

The Lenovo Solution Center program enables you to troubleshoot and resolve computer problems. It combines diagnostic tests, system information collection, security status, and support information, along with hints and tips for maximum system performance.

The Lenovo Solution Center program is available for download at <http://www.lenovo.com/diags>.

To run the Lenovo Solution Center program, go to Control Panel and click **System and Security** → **Lenovo - System Health and Diagnostics**, and then follow the instructions on the screen.

For more information about the Lenovo Solution Center program, refer to the help information system of the program.

Quick test programs

You can run quick test programs to troubleshoot and resolve computer problems, especially when the computer does not have the Lenovo Solution Center program installed.

Lenovo provides the following quick test programs:

- **Lenovo Hard Drive Quick Test:** Use this program to troubleshoot and resolve internal storage problems.
- **Lenovo Memory Quick Test:** Use this program to troubleshoot and resolve memory module problems.

The quick test programs are applicable on the following operating systems:

- Microsoft® Windows® 8
- Microsoft Windows 7
- Microsoft Windows XP
- Microsoft Windows Server® 2003
- Microsoft Windows Server 2008

To download and install a quick test program, go to <http://www.lenovo.com/diags> and follow the instructions on the Web site.

To run a test using a quick test program, do the following:

1. Go to the C:\SWTOOLS\ldiag directory.
2. Double-click the gui_lsc_lite.exe file.
3. When the **User Account Control** window opens, click **Yes**.
4. Select the device class to be tested.
5. Select the devices to be tested.
6. Select the test to be performed.
7. Follow the instructions on the screen to start the test. When a problem is detected, information messages are displayed. Refer to the messages to troubleshoot the problem.

UEFI diagnostic program

A UEFI diagnostic program is preinstalled on the computer. It enables you to test memory modules and internal storage devices, view system information, and check and recover bad sectors on internal storage devices.

To run the UEFI diagnostic program, do the following:

1. Turn on the computer. If the computer cannot be turned on, go to “Power system checkout” on page 30, and check the power sources. If an error code is displayed, go to “Symptom-to-FRU index” on page 38 for error code descriptions and troubleshooting hints.
2. When the ThinkPad logo is displayed, repeatedly press and release the F10 key. The main screen of the UEFI diagnostic program is displayed.
3. Follow the instructions on the screen to use the diagnostic program.

The options on the main screen are as follows:

Table 1. Items on the main screen of the UEFI diagnostic program

Tests	Tools
<ul style="list-style-type: none">• Quick Memory Test• Quick Storage Device Test• Exit Application	<ul style="list-style-type: none">• System Information• Recover Bad Sectors Tool

Bootable diagnostic programs

If the computer you are servicing is not installed with the UEFI diagnostic program, you can download a bootable diagnostic program from the Lenovo Support Web site. The bootable diagnostic programs enable you to test computer memory and internal storage devices, view system information, and check and recover the internal storage devices. To use the bootable diagnostic programs, you can create a bootable diagnostic medium on a USB device or CD.

To create a bootable diagnostic medium, do the following:

1. Go to <http://www.lenovo.com/diags>.
2. Click **Lenovo Bootable Diagnostics**.
3. Follow the instructions on the Web site to create a bootable diagnostic medium on a USB device or CD.

To use the diagnostic medium you have created, do one of the following:

- If you have created the bootable diagnostic medium on a USB device, do the following:
 1. Attach the USB device to the computer.
 2. Turn on the computer. If the computer cannot be turned on, go to “Power system checkout” on page 30, and check the power sources. If an error code is displayed, go to “Symptom-to-FRU index” on page 38 for error code descriptions and troubleshooting hints.
 3. When the ThinkPad logo is displayed, repeatedly press and release the F12 key. When the Boot Menu window opens, release the F12 key.
 4. Use the arrow keys to select **USB HDD** and then press Enter. The diagnostic program will be launched automatically.
 5. Follow the instructions on the screen to use the diagnostic program.
- If you have created the bootable diagnostic medium on a CD, do the following:
 1. Turn on the computer. If the computer cannot be turned on, go to “Power system checkout” on page 30, and check the power sources. If an error code is displayed, go to “Symptom-to-FRU index” on page 38 for error code descriptions and troubleshooting hints.
 2. Insert the CD into the optical drive.
 3. Restart the computer.
 4. When the ThinkPad logo is displayed, repeatedly press and release the F12 key. When the Boot Menu window opens, release the F12 key.
 5. Use the arrow keys to select **ATAPI CDx** (x: 0, 1, ...) and then press Enter. The diagnostic program will be launched automatically.
 6. Follow the instructions on the screen to use the diagnostic program.

Power system checkout

To verify a symptom, do the following:

1. Turn off the computer.
2. Remove the battery pack.
3. Connect the ac power adapter.
4. Check that power is supplied when you turn on the computer.
5. Turn off the computer.
6. Disconnect the ac power adapter and install the charged battery pack.
7. Check that the battery pack supplies power when you turn on the computer.

If you suspect a power problem, see the appropriate one of the following power supply checkouts:

- “Checking the ac power adapter” on page 30
- “Checking operational charging” on page 31
- “Checking the battery pack” on page 31
- “Checking the backup battery” on page 32

Checking the ac power adapter

You are here because the computer fails only when the ac power adapter is used.

- If the power problem occurs only when the docking station or the port replicator is used, replace the docking station or the port replicator.
- If the power-on indicator does not turn on, check the power cord of the ac power adapter for correct continuity and installation.
- If the computer does not charge during operation, go to “Checking operational charging” on page 31.

To check the ac power adapter, do the following:

1. Unplug the ac power adapter cable from the computer.
2. Measure the output voltage at the plug of the ac power adapter cable. See the following illustration:

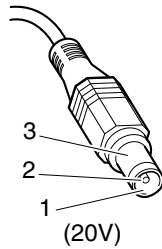

Pin	Voltage (V dc)
1	+20
2	0
3	Ground

Note: Output voltage of pin 2 of the ac power adapter might differ from the one you are servicing.

3. If the voltage is not correct, replace the ac power adapter.
4. If the voltage is acceptable, replace the system board.

Note: Noise from the ac power adapter does not always indicate a defect.

Checking operational charging

To check whether the battery charges properly during operation, use a discharged battery pack or a battery pack that has less than 50% of the total power remaining when installed in the computer.

Perform operational charging. If the battery status indicator or icon does not turn on, remove the battery pack and let it return to room temperature. Reinstall the battery pack. If the charge indicator or icon still does not turn on, replace the battery pack.

If the charge indicator still does not turn on, replace the system board. Then reinstall the battery pack. If it is still not charged, go to the next topic.

Checking the battery pack

The battery status icon in the Windows notification area displays the percentage of battery power remaining.

To check for detailed battery status information, do the following:

- For Windows 7: Open the Power Manager program and click the **Battery** tab.
- For Windows 8: Open the Lenovo Support program and click **Battery Health**, or open the Lenovo Settings program and click **Power**.

Note: If the battery pack becomes hot, it may not be able to charge. Remove it from the computer and leave it at room temperature for a while. After it cools down, reinstall and recharge it.

To check the battery pack, do the following:

1. Power off the computer.
2. Remove the battery pack and measure the voltage between battery terminals 1 (+) and 7 (-). See the following illustration:

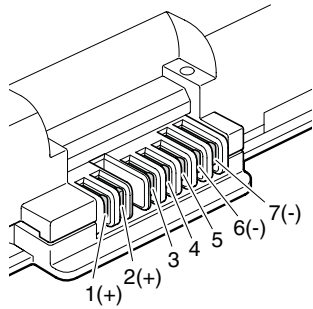

Terminal	Voltage (V dc)
1	+ 0 to + 16.8
7	Ground (-)

- If the voltage is less than +11.0 V dc, the battery pack has been discharged.

Note: Recharging will take at least 3 hours, even if the indicator does not turn on.

If the voltage is still less than +11.0 V dc after recharging, replace the battery.

- If the voltage is more than +11.0 V dc, measure the resistance between battery terminals 5 and 7. The resistance must be 4 to 30 K Ω . If the resistance is not correct, replace the battery pack. If the resistance is correct, replace the system board.

Checking the backup battery

Do the following:

- Power off the computer, and unplug the ac adapter from it.
- Turn the computer upside down.
- Remove the battery pack. See “1010 Battery pack” on page 60.
- Remove the backup battery. See “1090 Backup battery” on page 80.
- Measure the voltage of the backup battery. See the following illustration.

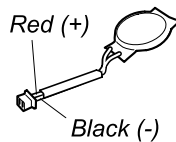

Wire	Voltage (V dc)
Red	+2.5 to +3.2
Black	Ground

- If the voltage is correct, replace the system board.
- If the voltage is not correct, replace the backup battery.
- If the backup battery discharges quickly after replacement, replace the system board.

Chapter 4. Related service information

This chapter presents following information:

- “Restoring the factory contents by using Recovery Disc Set” on page 33
- “Using the Windows recovery programs on the Windows 8 operating system” on page 34
- “Passwords” on page 35
- “Power management” on page 37
- “Symptom-to-FRU index” on page 38

Service Web site: When the latest maintenance diskette and the system program service diskette become available, they will be posted on <http://www.lenovo.com/support>

Restoring the factory contents by using Recovery Disc Set

When the hard disk drive or solid-state drive is replaced because of a failure, no product recovery program is on the new drive. In this case, you must use the Recovery Disc Set for the computer. Order the Recovery Disc Set and the drive at the same time so that you can recover the new drive with the pre-installed software when they arrive. For information on which discs to order, see <http://www.lenovo.com/serviceparts-lookup>.

The recovery disc set consists of the user instructions and the following set of DVDs to restore the computer to the original factory configuration.

- **Operating System Recovery Disc (one disc):** This disc restores the Microsoft Windows operating system. Use this disc to start the recovery process.
- **Applications and Drivers Recovery Disc (one or more discs):** This disc restores the preinstalled applications and drivers on the computer.
- **Supplemental Recovery Disc:** This disc contains additional content, such as updates to the software that was preinstalled on the computer. Not all recovery disc sets come with a *Supplemental Recovery Disc*.

Notes:

- You must have a DVD drive to use the recovery discs. If you do not have an internal DVD drive, you can use an external USB DVD drive.
- During the recovery process, all data on the drive will be deleted. If possible, copy any important data or personal files that you want to keep onto removable media or a network drive before you start the recovery process.

To restore the computer to the original factory configuration using the recovery disc set, do the following:

Note: Recovery can take one to two hours to complete. The length of time depends on the method you use. If you use recovery discs, the recovery process will take about two hours.

1. Make the CD/DVD drive the first startup device in the startup sequence using the following procedure:
 - a. Press and hold down the F1 key, and then turn on the computer. When the logo screen is displayed or if you hear repeating beeps, release the F1 key. The ThinkPad Setup program opens.
 - b. Use the arrow keys to select **Startup → Boot**.
 - c. Select the CD/DVD drive as the **1st Boot Device**.
2. Insert the *Operating System Recovery Disc* into the DVD drive.
3. Press Fn+F10 to save the ThinkPad Setup configuration changes. Follow the instructions on the screen to begin the recovery process.
4. Select your language and click **Next**.

5. Read the license. If you agree with the terms and conditions, select **I accept these terms and conditions** and then click **Next**. If you do not agree with the terms and conditions, follow the instructions on the screen.
6. Click **Yes** in the displayed window to begin the operating system recovery process.
7. Insert the *Applications and Drivers Recovery Disc*, when prompted and then click **OK** to begin the applications and drivers recovery process.
8. If you have a *Supplemental Recovery Disc*, insert it when prompted and click **Yes**. If you do not have a *Supplemental Recovery Disc*, click **No**.
9. When all of the data has been copied from the last disc in the set and has been processed, remove the disc and restart the computer.

Note: The rest of the recovery process is fully automated and no action is required by you. The computer will restart into the Microsoft Windows desktop several times and you might experience periods when no activity is apparent on the screen for several minutes at a time. This is normal.

10. When the recovery process is complete, the Set Up Windows screen is displayed. Follow the instructions on the screen to complete the Windows setup.
11. After you have completed the Windows setup, you might want to restore the original startup sequence. Start ThinkPad Setup and then press F9 to restore the default settings. Press F10 to save and exit ThinkPad Setup.

Note: After restoring a drive to the factory default settings, you might need to reinstall some device drivers.

Using the Windows recovery programs on the Windows 8 operating system

The computer you are servicing might come with built-in recovery programs provided by the Windows 8 operating system. Use those programs to refresh or reset the computer.

Refreshing the computer

If the computer you are servicing does not perform well and the problem might be caused by a recently installed program, you can refresh the computer without losing the customers' personal files or changing the settings.

Attention: If you refresh the computer, the programs that came with the computer and the programs that were installed from Windows Store will be reinstalled, but all other programs will be removed.

To refresh the computer, do the following:

1. Move your cursor to the bottom-right corner of the screen to bring up the charms. Click **Settings** → **Change PC settings** → **General**.
2. In the **Refresh your PC without affecting your files** section, click **Get started**.

Resetting the computer to factory default settings

You can reset the computer to the factory default settings. During the process, the operating system and all programs that are shipped with the computer will be reinstalled.

Attention: All the personal files and settings will be deleted after you reset the computer to the factory default settings. Ensure that the user has made a backup copy of all the data before restoring the computer to the factory default settings.

To reset your computer, do the following:

1. Move your cursor to the bottom-right corner of the screen to bring up the charms. Click **Settings** → **Change PC settings** → **General**.
2. In the **Remove everything and reinstall Windows** section, click **Get started**.

Advanced startup options

Advanced startup options enable you to change the startup settings of the Windows operating system, start the computer from an external device, or restore the Windows operating system from a system image.

To use the advanced startup options, do the following:

1. Move your cursor to the bottom-right corner of the screen to bring up the charms. Click **Settings** → **Change PC settings** → **General**.
2. In the **Advanced startup** section, click **Restart now** → **Troubleshoot** → **Advanced options**.
3. Restart the computer following the instructions on the screen.

For more details about the Windows recovery solutions, refer to the help information system of the Windows 8 operating system.

Passwords

As many as three passwords may be needed for any ThinkPad notebook computer: the power-on password, the hard disk password, and the supervisor password.

If any of these passwords has been set, a prompt for it will be displayed on the screen whenever the computer is turned on. The computer does not start until the password is entered.

Note: If only a supervisor password is set, the password prompt will not be displayed when the operating system is started.

Power-on password

A power-on password protects the system from being powered on by an unauthorized person. The password must be turned on before an operating system can be started. For instructions on how to remove the power-on password, see “How to remove the power-on password” on page 36.

Hard disk password

There are two kinds of hard disk passwords:

- User hard disk password - for the user
- Master hard disk password - for the system administrator, who can use it to get access to the hard disk even if the user has changed the user hard disk password

Note: There are two modes for the hard disk password: **User only** and **Master + User**. The **Master + User** mode requires two hard disk passwords; the system administrator enters both in the same operation. The system administrator then provides the user hard disk password to the system user.

Attention: If the user hard disk password has been forgotten, check whether a master hard disk password has been set. If it has, it can be used for access to the hard disk drive. If no master hard disk password is available, neither Lenovo nor Lenovo authorized service technicians provide any services to reset either the user or the master hard disk password, or to recover data from the hard disk drive. The hard disk drive can be replaced for a scheduled fee.

For how to remove the hard disk password, see “How to remove the hard disk password” on page 36.

Supervisor password

A supervisor password protects the system information stored in the ThinkPad Setup. The user must enter the supervisor password in order to get access to the ThinkPad Setup and change the system configuration.

Attention: If the supervisor password has been forgotten and cannot be made available to the service technician, there is no service procedure to reset the password. The system board must be replaced for a scheduled fee.

How to remove the power-on password

To remove a power-on password, do the following:

If no supervisor password has been set, do the following to remove the power-on password:

1. Turn off the computer.
2. Remove the battery pack. For instructions on how to remove the battery pack, see “1010 Battery pack” on page 60.
3. Remove the backup battery. For instructions on how to remove the backup battery, see “1090 Backup battery” on page 80. Wait for a few seconds.
4. Reinstall the backup battery. For instructions on how to install the backup battery, see “1090 Backup battery” on page 80.
5. Reinstall the battery pack. For instructions on how to install the battery pack, see “1010 Battery pack” on page 60.
6. Turn on the computer and wait until the POST ends. After the POST ends, the password prompt does not appear. The power-on password has been removed.

If a supervisor password has been set and is known to the service technician, do the following to remove the power-on password:

1. Turn on the computer.
2. When the ThinkPad logo comes up, immediately press F1.
3. Type the supervisor password to enter the ThinkPad Setup program.
4. Select **Security**.
5. Select **Password**.
6. Select **Power-On Password**.
7. Type the current supervisor password in the **Enter Current Password** field. then leave the **Enter New Password** field blank, and press Enter twice.
8. In the Changes have been saved window, press Enter.
9. Press F10 to save changes and exit the ThinkPad Setup program.

How to remove the hard disk password

Attention: If **User only** mode is selected and the user hard disk password has been forgotten and cannot be made available to the service technician, neither Lenovo nor Lenovo authorized service technicians provide any services to reset the user hard disk passwords or to recover data from the hard disk drive. The hard disk drive can be replaced for a scheduled fee.

To remove a user hard disk password that has been forgotten, when the supervisor password and master hard disk password are known, do the following:

1. Turn on the computer.
2. When the ThinkPad logo comes up, immediately press F1 to enter ThinkPad Setup. When power-on password icon is appearing on the screen, enter the power-on password.
3. Select **Security**.
4. Select **Password**.
5. Select **Hard-disk x password**, where x is the letter of the hard disk drive. A pop-up window opens.
6. Select **Master hard disk password**.

7. Type the current master hard disk password in the **Enter Current Password** field. Then leave the **Enter New Password** field blank, and press Enter twice.
8. Press F10.
9. Press F10 to save changes and exit the ThinkPad Setup program. The user hard disk password and the master hard disk password have been removed.

Power management

To reduce power consumption, the computer has three power management modes: screen blank, sleep, and hibernation.

Screen blank mode (for the Windows 7 operating system only)

If the time set on the “Turn off monitor” timer in the operating system expires, the LCD backlight turns off.

To put the computer into screen blank mode, do the following:

1. Right-click the battery gauge in the task bar.
2. Select **Power off display**.

To end screen blank mode and resume normal operation, press any key.

Sleep mode

When the computer enters sleep mode, the following events occur in addition to what occurs in screen blank mode:

- The LCD is powered off.
- The hard disk drive is powered off.
- The microprocessor stops.

To enter sleep mode, press Fn+F4.

In certain circumstances, the computer goes into sleep mode automatically:

- After a period of inactivity specified in power plan settings
- When the battery indicator blinks orange, indicating that the battery power is low

To cause the computer to return from sleep mode and resume operation, do one of the following:

- Press the Fn key.
- Open the LCD cover.
- Turn on the power button.

Also, in either of the following events, the computer automatically returns from sleep mode and resumes operation:

- The ring indicator (RI) is signaled by a serial device or a PC Card device.
- The time set on the resume timer elapses.

Note: The computer does not accept any input immediately after it enters sleep mode. Wait a few seconds before taking any action to reenter operation mode.

Hibernation mode

In hibernation mode, the following occurs:

- The system status, RAM, VRAM, and setup data are stored on the hard disk.

- The system is powered off.

Note: If the computer enters the hibernation mode while it is docked to the docking station, do not undock it before resuming normal operation. If you do undock it and then try to resume normal operation, you will get an error message, and you will have to restart the system.

If you have defined one of the following actions as the event that causes the system to go into hibernation mode, perform that action.

- Closing the lid.
- Pressing the power button.
- Pressing Fn+F4 keys.

Also, the computer goes into hibernation mode automatically after a period of inactivity specified in power plan settings

When the power is turned on, the computer returns from hibernation mode and resumes operation. The hibernation file in the boot record on the hard disk drive is read, and system status is restored from the hard disk drive.

Symptom-to-FRU index

This section contains following information:

- “Numeric error codes” on page 39
- “Error messages” on page 40
- “Beep symptoms” on page 40
- “No-beep symptoms” on page 41
- “LCD-related symptoms” on page 41
- “Intermittent problems” on page 42
- “Undetermined problems” on page 42

The symptom-to-FRU index in this section lists symptoms and errors and their possible causes. The most likely cause is listed first, in boldface type.

Note: Do the FRU replacement or other actions in the sequence shown in the column headed “FRU or action, in sequence.” If replacing a FRU does not solve the problem, put the original part back in the computer. Do not replace a nondefective FRU.

This index can also help you determine, during regular servicing, what FRUs are likely to need to be replaced next.

A numeric error is displayed for each error detected in POST or system operation. In the displays, **n** can be any number.

If no numeric code is displayed, check the narrative descriptions of symptoms. If the symptom is not described there, go to “Intermittent problems” on page 42.

Note: For a device not supported by diagnostic codes in the ThinkPad notebook computers, see the manual for that device.

Numeric error codes

Table 2. Numeric error codes

Symptom or error	FRU or action, in sequence
0177 Bad SVP data, stop POST task—The checksum of the supervisor password in the EEPROM is not correct.	System board.
0182 Bad CRC2. Enter BIOS Setup and load Setup defaults.—The checksum of the CRS2 setting in the EEPROM is not correct.	<ol style="list-style-type: none"> 1. Run ThinkPad Setup. Press F9, and Enter to load the default setting. Then save the current setting by pressing F10. 2. System board.
0183 Bad CRC of Security Settings in EFI Variable. Enter ThinkPad Setup.	
0187 EAIA data access error—The access to EEPROM is failed.	System board.
0188 Invalid RFID Serialization Information Area.	
0189 Invalid RFID configuration information area—The EEPROM checksum is not correct.	
0190 Critical low-battery error	System board.
0191 System Security—Invalid Remote Change requested.	System board.
0199 System Security— Security password retry count exceeded.	<ol style="list-style-type: none"> 1. Run ThinkPad Setup, and then save the current setting by pressing F10. 2. System board.
0251 System CMOS checksum bad— Default configuration used.	<ol style="list-style-type: none"> 1. Charge the backup battery for more than 8 hours by connecting the ac power adapter. 2. Replace the backup battery and run ThinkPad Setup to reset the time and date.
1802 Unauthorized network card is plugged in—Turn off and remove the miniPCI network card.	<ol style="list-style-type: none"> 1. Remove Mini PCI network card. 2. System board.
1820 More than one external fingerprint reader is attached. Power off and remove all but the reader that you set up within your main operating system.	Remove all but the reader that you set up for the authentication.
2000 Hard Drive Active Protection sensor diagnostics failed.Press <Esc> to continue.Press <F1> to enter SETUP	<ol style="list-style-type: none"> 1. Undock docking station or port replicator if it is attached to the ThinkPad Notebook. 2. Place the ThinkPad Notebook on a horizontal surface. Do not apply any physical shock to the computer. 3. Run Diagnostics → ThinkPad Device → HDD Active Protection Test.
2100 Detection error on HDD0 (Main HDD)	<ol style="list-style-type: none"> 1. Reseat the hard disk drive. 2. Main hard disk drive. 3. System board.
2101 Detection error on HDD1 (Ultrabay HDD)	<ol style="list-style-type: none"> 1. Reseat the hard disk drive. 2. Ultrabay® hard disk drive. 3. System board.

Table 2. Numeric error codes (continued)

Symptom or error	FRU or action, in sequence
2102 Detection error on HDD2 (Mini SATA)	<ol style="list-style-type: none"> Reseat the Mini SATA device. Mini SATA device. System board.
2110 Read error on HDD0 (Main HDD)	<ol style="list-style-type: none"> Reseat the hard disk drive. Main hard disk drive. System board.
2111 Read error on HDD1 (Ultrabay HDD)	<ol style="list-style-type: none"> Reseat the hard disk drive. Ultrabay hard disk drive. System board.
2112 Read error on HDD2 (Mini SATA)	<ol style="list-style-type: none"> Reseat the Mini SATA device. Mini SATA device. System board.
2200 Machine Type and Serial Number are invalid.	System board.
2201 Machine UUID is invalid.	System board.

Error messages

Table 3. Error messages

Symptom or error	FRU or action, in sequence
Fan error.	<ol style="list-style-type: none"> Fan. Thermal grease. System board.
Thermal sensing error.	System board.
The battery installed is not supported by this system and will not charge. Please replace the battery with the correct Lenovo battery for this system. Press the ESC key to continue.	Replace the battery.

Beep symptoms

Table 4. Beep symptoms

Symptom or error	FRU or action, in sequence
One beep and a blank, unreadable, or flashing LCD.	<ol style="list-style-type: none"> Reseat the LCD connector. LCD assembly. External CRT. System board.
One long and two short beeps, and a blank or unreadable LCD.	<ol style="list-style-type: none"> System board. LCD assembly. memory module.
Two short beeps with error codes.	POST error. See Numeric error codes.
Two short beeps and a blank screen.	<ol style="list-style-type: none"> System board. memory module.
Two or more beeps, or a continuous beep. Operating system starts successfully.	If a mini-PCI Ethernet card is installed, confirm that Alert On LAN 2 in ThinkPad Setup is disabled .

Table 4. Beep symptoms (continued)

Symptom or error	FRU or action, in sequence
Three short beeps, pause, three more short beeps, and one short beep.	<ol style="list-style-type: none"> 1. memory module. 2. System board
One short beep, pause, three short beeps, pause, three more short beeps, and one short beep.	
Only the cursor appears.	Reinstall the operating system.
Four cycles of four short beeps and a blank screen.	System board (security chip)
Five short beeps and a blank screen.	System board

No-beep symptoms

Table 5. No-beep symptoms

Symptom or error	FRU or action, in sequence
No beep, power-on indicator on, LCD blank, and no POST.	<ol style="list-style-type: none"> 1. Make sure that every connector is connected tightly and correctly. 2. memory module. 3. System board.
No beep, power-on indicator on, and LCD blank during POST.	<ol style="list-style-type: none"> 1. Reseat memory module. 2. System board.
The power-on password prompt appears.	A power-on password or a supervisor password is set. Type the password and press Enter .
The hard-disk password prompt appears.	A hard-disk password is set. Type the password and press Enter .

LCD-related symptoms

Important: The TFT LCD for the notebook computer contains many thin-film transistors (TFTs). The presence of a small number of dots that are missing, discolored, or always lighted is characteristic of TFT LCD technology, but excessive pixel problems can cause viewing concerns. If the LCD you are servicing has two or less visible defective pixels, it should not be considered faulty. However, if the LCD has three or more visible defective pixels, it will be deemed as defective by Lenovo and it should be replaced.

Notes:

- This policy applies to all ThinkPad notebooks purchased on 1 January, 2008 or later.
- Lenovo will not provide replacement if the LCD is within specification as we cannot guarantee that any replacement LCD will have zero pixel defects.
- One pixel consists of R, G, B sub-pixels.

Table 6. LCD-related symptoms

Symptom or error	FRU or action, in sequence
No beep, power-on indicator on, and a blank LCD during POST.	System board.
<ul style="list-style-type: none"> • LCD backlight not working. • LCD too dark. • LCD brightness cannot be adjusted. • LCD contrast cannot be adjusted. 	<ol style="list-style-type: none"> 1. Reseat the LCD connectors. 2. LCD assembly. 3. System board.

Table 6. LCD-related symptoms (continued)

Symptom or error	FRU or action, in sequence
<ul style="list-style-type: none"> • LCD screen unreadable. • Characters missing pixels. • Screen abnormal. • Wrong color displayed. 	<ol style="list-style-type: none"> 1. See important note for “LCD-related symptoms.” 2. Reseat all LCD connectors. 3. LCD assembly. 4. System board.
Horizontal or vertical lines displayed on LCD.	LCD assembly.

Intermittent problems

Intermittent system hang problems can be due to a variety of causes that have nothing to do with a hardware defect, such as cosmic radiation, electrostatic discharge, or software errors. FRU replacement should be considered only when a problem recurs.

When analyzing an intermittent problem, do the following:

1. Run the diagnostic test for the system board in loop mode **at least 10 times**.
2. If no error is detected, do **not** replace any FRUs.
3. If any error is detected, replace the FRU shown by the FRU code. Rerun the test to verify that no more errors exist.

Undetermined problems

If the diagnostic tests did not identify the adapter or device that has failed, if wrong devices are installed, or if the system simply is not operating, follow these procedures to isolate the failing FRU (do not isolate FRUs that have no defects).

Verify that all attached devices are supported by the computer.

Verify that the power supply being used at the time of the failure is operating correctly. See “Power system checkout” on page 30.

1. Turn off the computer.
2. Visually check each FRU for damage. Replace any damaged FRU.
3. Remove or disconnect all of the following devices:
 - a. Non-ThinkPad devices
 - b. Devices attached to the docking station or the port replicator
 - c. Printer, mouse, and other external devices
 - d. Battery pack
 - e. Hard disk drive
 - f. External diskette drive or optical drive
 - g. Memory module
 - h. Optical disk in the internal drive
 - i. PC cards
4. Turn on the computer.
5. Determine whether the problem has been solved.
6. If the problem does not recur, reconnect the removed devices one at a time until you find the failing FRU.
7. If the problem remains, replace the following FRUs one at a time (do not replace a nondefective FRU):
 - a. System board
 - b. LCD assembly

Chapter 5. Status indicators

This chapter presents the system status indicators that show the status of the computer.

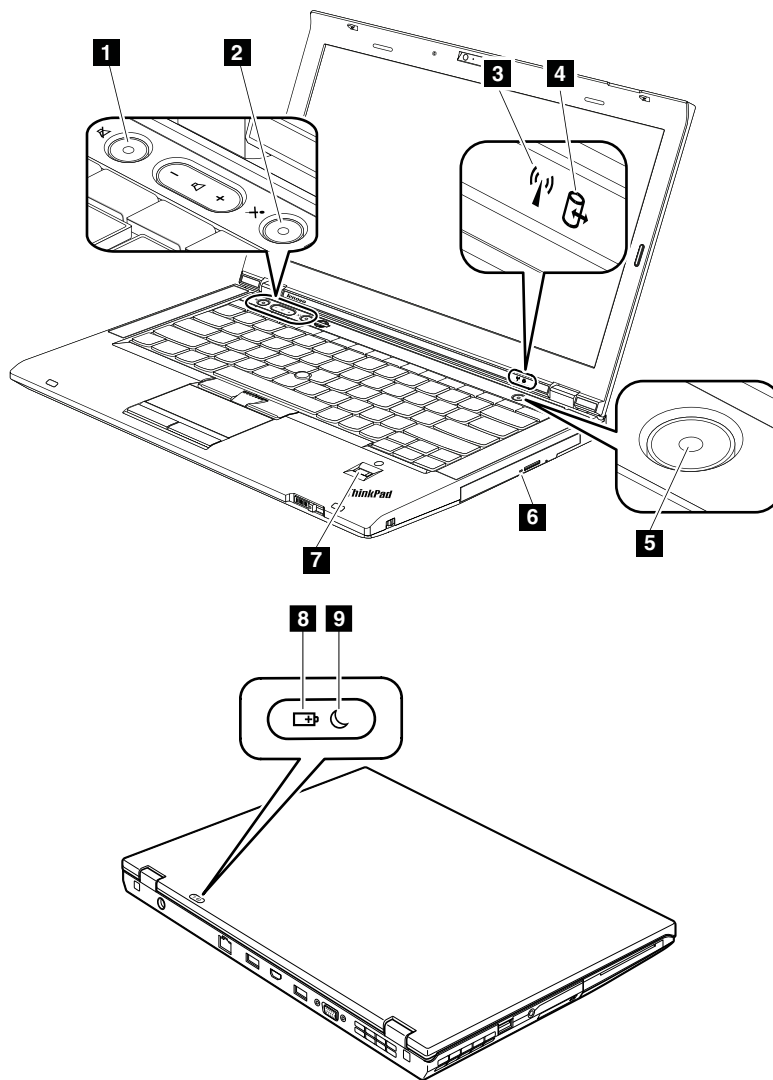

Table 7. Status indicators









Indicator	Meaning
1 Speaker mute indicator 	Orange: The speakers are on mute. To mute or unmute the speakers, press the speaker mute button.
2 Microphone mute indicator 	Orange: By default, when the microphones are on mute, none of the recording devices is available.

Table 7. Status indicators (continued)

Indicator	Meaning
<p>3 Wireless LAN, Wireless WAN, or WiMAX status indicator</p> 	<p>Green: The wireless LAN feature, wireless WAN feature, or WiMAX feature is on, or data is being transmitted.</p> <p>Off: Wireless network devices are disabled or the wireless radio is turned off.</p>
<p>4 Device access indicator</p> 	<p>Green: Data is being read from or written to the hard disk drive, solid-state drive, or the device in the Serial Ultrabay Slim bay. When this indicator is on, do not put the computer into sleep mode or turn off the computer.</p> <p>Note: Do not move the computer while the indicator is on. Sudden physical shock could cause drive errors.</p>
<p>5 Power-on indicator</p> 	<p>Green: The computer is on and ready to use.</p> <p>Blinking green: The computer is in sleep mode.</p> <p>Turn off: The computer is off.</p>
<p>6 Serial Ultrabay Slim device status indicator</p>	<p>Green: A Serial Ultrabay Slim device is installed and in use.</p> <p>Blinking green: A Serial Ultrabay Slim device is being detached or attached.</p>
<p>7 Fingerprint reader status indicator</p> 	<p>Green: The fingerprint reader is ready to swipe.</p> <p>Blinking green: The fingerprint is being authenticated or has been authenticated.</p> <p>Blinking orange: The fingerprint could not be authenticated.</p>
<p>8 Battery status indicator</p> 	<p>Green:</p> <ul style="list-style-type: none"> The battery charge level is 80% or higher. The battery charge level is between 20% and 80%, and the battery is not charging. <p>Slow blinking green: The battery charge level is between 20% and 80%, and the battery is charging.</p> <p>Orange: The battery charge level is between 5% and 20%, and the battery is not charging.</p> <p>Slow blinking orange: The battery charge level is between 5% and 20%, and the battery is charging.</p> <p>Fast blinking orange: The battery charge level is lower than 5%.</p> <p>Quick blinking orange: An error has occurred in the battery.</p> <p>Blinking three times: The ac power adapter is being attached to the computer.</p> <p>Off: The battery pack is detached or the computer is turned off.</p> <p>Note: If the computer is operating on battery power, the battery status indicator does not work while the computer is turned off or is in sleep mode or hibernation mode.</p>
<p>9 Sleep status indicator</p> 	<p>Green: The computer is in sleep mode.</p> <p>Blinking green: The computer is entering sleep mode, or hibernation mode, or is resuming normal operation.</p>

Chapter 6. Fn key combinations

The following table describes the functions of Fn key combinations.

Table 8. Fn key combinations

Key combination	Description
Fn+F3	Locks the computer.
Fn+F4	Puts the computer into sleep mode. To resume normal operation, press the Fn key. Notes: <ul style="list-style-type: none">• To use the Fn+F4 key combination, you must have the ThinkPad Power Management driver installed on the computer.• If you want to use the combination to put the computer into hibernation mode, change the power plan settings.
Fn+F5	Enables or disables the built-in wireless networking features.
Fn+F6	<ul style="list-style-type: none">• For Windows 7: Opens the Communications settings window, in which you can preview your video image, take a snapshot of your current image, and change the camera and audio settings.• For Windows 8: Starts the Lenovo Settings program, which enables you to change the camera and audio settings.
Fn+F7	Switches between the computer display and an external monitor. Note: You also can use the Windows+P combination to switch between the computer display and an external monitor.
Fn+F8	The computer display becomes dimmer.
Fn+F9	The computer display becomes brighter.
Fn+F10	Previous track/scene
Fn+F11	Play or pause
Fn+F12	Next track/scene
Fn+Spacebar	Controls the keyboard backlight and the ThinkLight® light. <ul style="list-style-type: none">• Press once: Turn on the keyboard backlight in the low brightness level.• Press again: Adjust the keyboard backlight to the high brightness level.• Press the third time: Turn off the keyboard backlight and turn on the ThinkLight light.• Press the fourth time: Turn off the ThinkLight light. Note: If the computer you are servicing does not have a backlit keyboard, the Fn+Spacebar combination controls only the ThinkLight light.
Fn+B	Has the same function as the Break key.
Fn+P	Has the same function as the Pause key.
Fn+S	Has the same function as the SysRq key.
Fn+K	Has the same function as the ScrLK key.

Chapter 7. Locations

This chapter introduces the locations of the computer hardware components.

Locating computer controls, connectors, and indicators

This topic introduces the locations of the computer controls, connectors, and indicators.

Front view

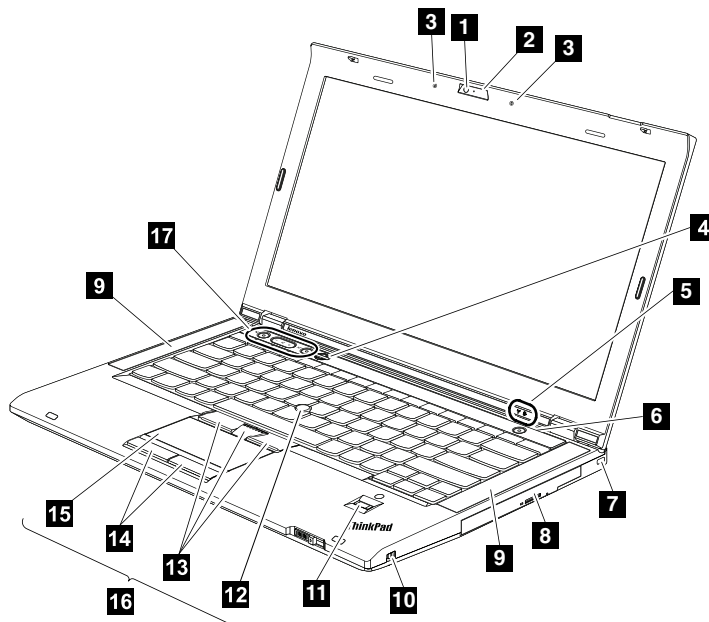

- | | |
|---|---|
| 1 Integrated camera (on some models) | 10 Wireless radio switch |
| 2 ThinkLight light | 11 Fingerprint reader (on some models) |
| 3 Built-in microphones | 12 TrackPoint pointing stick |
| 4 Black button | 13 TrackPoint buttons |
| 5 Status indicators ¹ | 14 Touch pad buttons |
| 6 Power button | 15 Touch pad |
| 7 Security keyhole | 16 UltraNav [®] pointing device |
| 8 Serial Ultrabay Slim device or blank bezel (depending on models) | 17 Volume control buttons |
| 9 Built-in stereo speakers | |

¹: For the description of each indicator, see Chapter 5 “Status indicators” on page 43.

Rear view

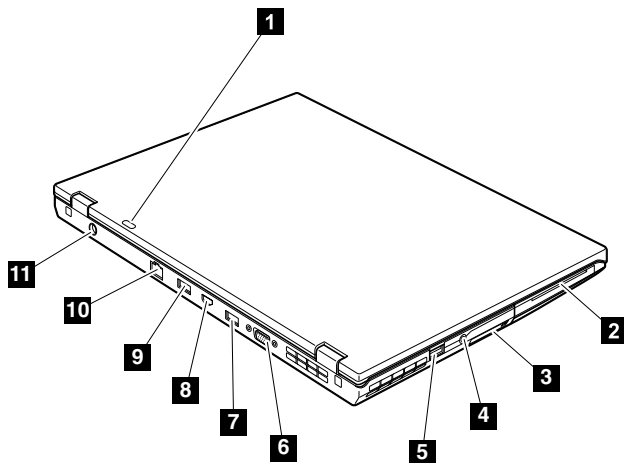

- | | |
|--|---|
| 1 Status indicators ¹ | 7 Always On USB connector |
| 2 Smart card reader slot (on some models) | 8 DisplayPort connector or Thunderbolt connector (depending on models) |
| 3 ExpressCard slot or 4-in-1 media card reader slot (depending on models) | 9 USB 3.0 connector |
| 4 Combo audio jack | 10 RJ45 Ethernet connector |
| 5 USB 3.0 connector | 11 ac power connector |
| 6 Video graphics array (VGA) connector | |

¹: For the description of each indicator, see Chapter 5 “Status indicators” on page 43.

Bottom view

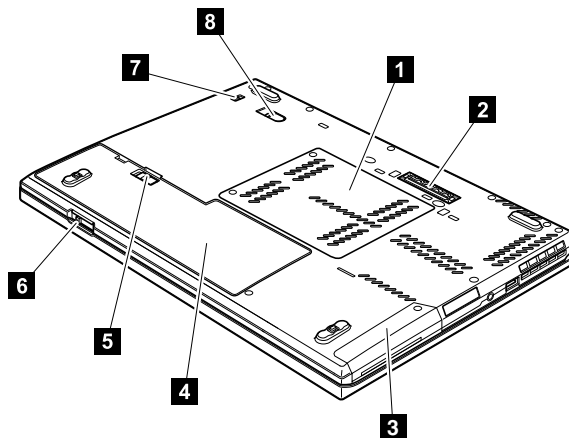

- | | |
|--|---|
| 1 Bottom cover (memory module, PCI Express Mini Card for wireless LAN and wireless WAN) | 5 Battery pack latch |
| 2 Docking connector | 6 LCD cover latch |
| 3 Solid-state drive or hard disk drive (depending on models) | 7 Serial Ultrabay Slim lock latch |
| 4 Battery pack | 8 Serial Ultrabay Slim eject latch |

Locating FRUs and CRUs

This topic introduces the following service parts:

- “Major FRUs and CRUs” on page 50
- “LCD FRUs” on page 52

Notes:

- Each FRU is available for all types or models, unless otherwise specified.
- **CRU statement for customers:**

You can resolve some problems with your product with a replacement part you can install yourself, called a “Customer Replaceable Unit” or “CRU.” Some CRUs are designated as self-service CRUs and others are designated as optional-service CRUs. *Installation of self-service CRUs is your responsibility. For optional-service CRUs, you can either install the CRU yourself or you can request that a Service Provider install the CRU according to the warranty service for your product.* If you intend on installing the CRU, Lenovo will ship the CRU to you. CRU information and replacement instructions are shipped with your product and are available from Lenovo at any time upon request. You can find a list of CRUs for your product in this *Hardware Maintenance Manual*. An electronic version of this manual can be found at <http://www.lenovo.com/support>. Click **User Guides & Manuals** and then follow the on-screen instructions to find the manual for your product. You might be required to return the defective part that is replaced by the CRU. When return is required: (1) return instructions, a prepaid shipping label, and a container will be included with the replacement CRU; and (2) you might be charged for the replacement CRU if Lenovo does not receive the defective CRU within thirty (30) days of your receipt of the replacement CRU. See your Lenovo Limited Warranty documentation for full details.

ThinkPad computers contain the following types of CRUs:

- **Self-service CRUs:** These CRUs unplug or are held by no more than two screws. Examples of these types of CRUs include the ac power adapter, power cord, battery, and hard disk drive. Other self-service CRUs depending on product design might include the memory module, wireless card, keyboard, and palm rest with finger print reader and touch pad.
- **Optional-service CRUs:** These CRUs are isolated parts within the computer that are concealed by an access panel that is typically secured by more than two screws. Once the access panel is removed, the specific CRU is visible.

Major FRUs and CRUs

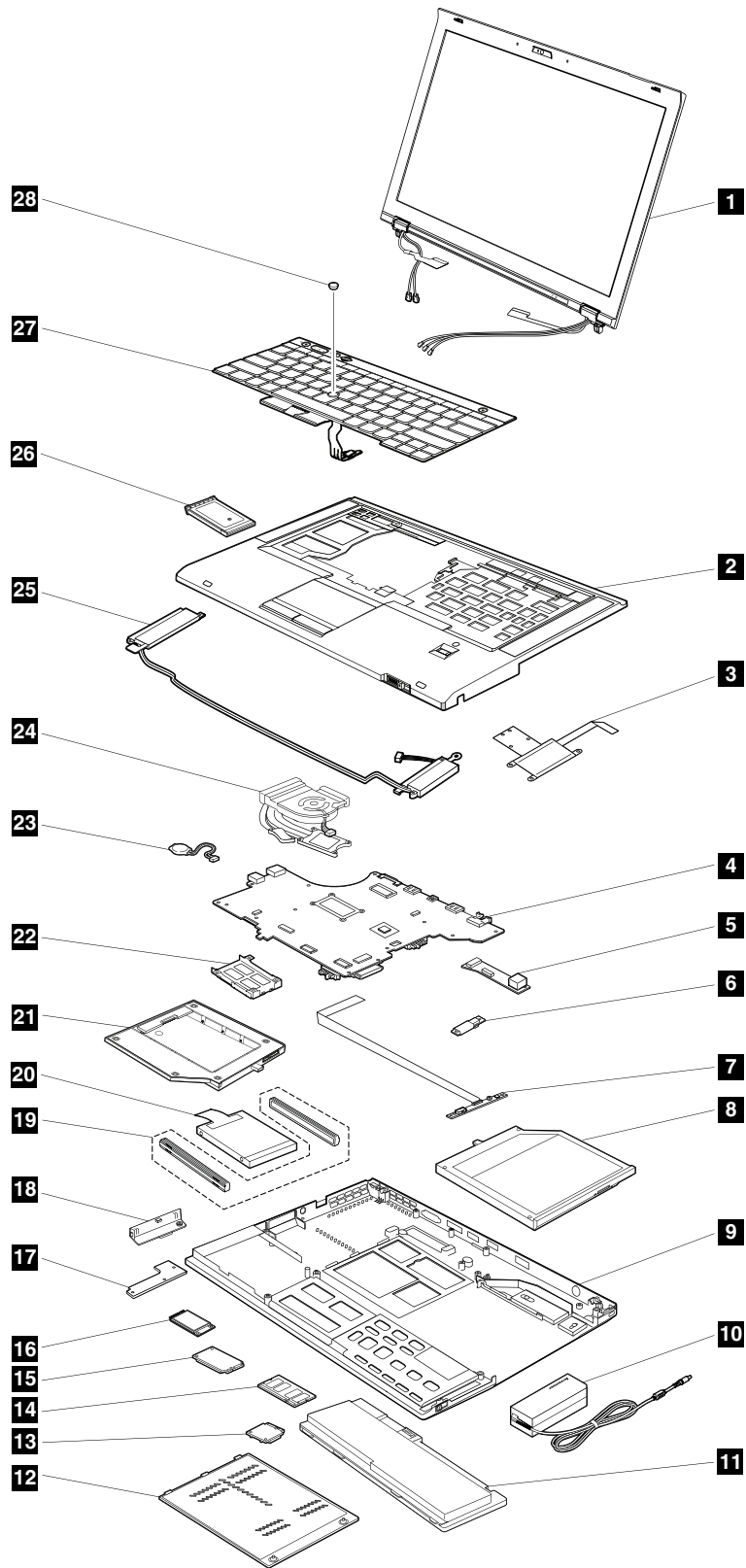
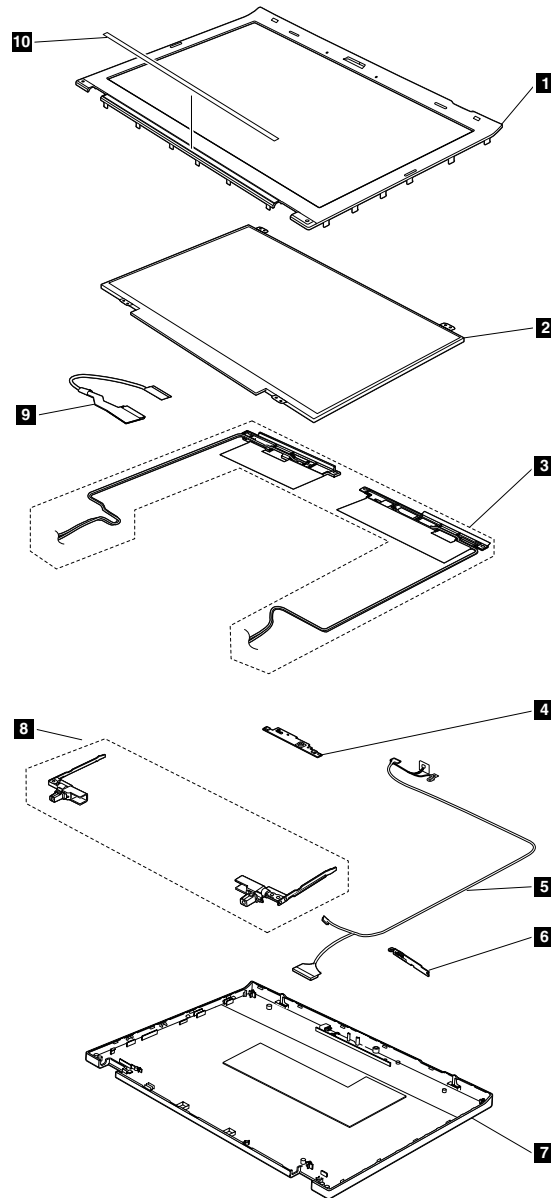

Table 9. Parts list—Overall

No.	FRU (Overall)	Self-service CRU	Optional service CRU
1	LCD unit	No	No
2	Keyboard bezel assembly	No	No
3	Smart card reader (on some models)	No	No
4	System board assembly	No	No
5	DC-in sub card	No	No
6	Bluetooth card (on some models)	No	No
7	Bluetooth wireless radio switch FPC	No	No
8	Serial Ultrabay Slim device or blank bezel (depending on models)	Yes	No
9	Base cover assembly	No	No
10	ac power adapter	Yes	No
11	Battery pack	Yes	No
12	Bottom cover	Yes	No
13	Wireless LAN card	No	Yes
14	Memory module	Yes	No
15	mSATA solid-state drive (on some models)	No	No
16	Wireless WAN card (on some models)	No	Yes
17	Hard disk drive sub card	No	No
18	Hard disk drive cover assembly	Yes	No
19	Hard disk drive rubber rails or solid-state drive spacers (depending on models)	Yes	No
20	Hard disk drive or solid-state drive (depending on models)	Yes	No
21	Second hard disk drive adapter (on some models)	Yes	No
22	ExpressCard reader (on some models)	Yes	No
23	Backup battery	Yes	No
24	Thermal fan assembly	No	No
25	Speaker assembly	No	No
26	4-in-1 media card reader adapter (on some models)	No	No
27	Keyboard	Yes	No
28	TrackPoint cap	Yes	No

LCD FRUs



No.	FRU	Self-service CRU	Optional service CRU
1	LCD bezel assembly	No	No
2	LCD panel	No	No
3	Antenna kit	No	No
4	Microphone sub card, integrated camera, or hall sensor sub card (depending on models)	No	No
5	LED cable assembly	No	No
6	LED sub card	No	No
7	LCD rear cover assembly	No	No
8	Hinge kit	No	No

No.	FRU	Self-service CRU	Optional service CRU
9	LCD cable assembly	No	No
10	Icon plate for LCD bezel	No	No

Looking up FRU information

For detailed FRU information, including part numbers, descriptions, and substitution part numbers, go to <http://www.lenovo.com/serviceparts-lookup>.

Chapter 8. FRU replacement notices

This chapter presents notices related to removing and replacing parts. Read this chapter carefully before replacing any FRU.

CRU statement for customers:

You can resolve some problems with your product with a replacement part you can install yourself, called a “Customer Replaceable Unit” or “CRU.” Some CRUs are designated as self-service CRUs and others are designated as optional-service CRUs. *Installation of self-service CRUs is your responsibility. For optional-service CRUs, you can either install the CRU yourself or you can request that a Service Provider install the CRU according to the warranty service for your product.* If you intend on installing the CRU, Lenovo will ship the CRU to you. CRU information and replacement instructions are shipped with your product and are available from Lenovo at any time upon request. You can find a list of CRUs for your product in this *Hardware Maintenance Manual*. An electronic version of this manual can be found at <http://www.lenovo.com/support>. Click **User Guides & Manuals** and then follow the on-screen instructions to find the manual for your product. You might be required to return the defective part that is replaced by the CRU. When return is required: (1) return instructions, a prepaid shipping label, and a container will be included with the replacement CRU; and (2) you might be charged for the replacement CRU if Lenovo does not receive the defective CRU within thirty (30) days of your receipt of the replacement CRU. See your Lenovo Limited Warranty documentation for full details.

Screw notices

Loose screws can cause a reliability problem. In the ThinkPad notebook computer, this problem is addressed with special nylon-coated screws that have the following characteristics:

- They maintain tight connections.
- They do not easily come loose, even with shock or vibration.
- They are harder to tighten.

Do the following when you service this machine:

- Keep the screw kit in your tool bag. For the part number of the screw kit, go to <http://www.lenovo.com/serviceparts-lookup>.
- It is recommended to use new screws.
- It is recommended to use each screw only once.

Tighten screws as follows:

- **Plastic to plastic**

Turn an additional 90 degrees after the screw head touches the surface of the plastic part.

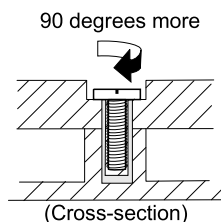

- **Logic card to plastic**

Turn an additional 180 degrees after the screw head touches the surface of the logic card.

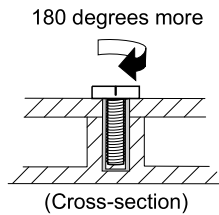

Notes:

- Ensure that you use the correct screw. It is recommended to use new screws for replacements. If you have a torque screwdriver, tighten all screws firmly to the torque specified in the screw information table for each step.
- Ensure that torque screwdrivers are calibrated correctly following country specifications.

Retaining serial numbers

This section includes the following descriptions:

- “Restoring the serial number of the system unit” on page 56
- “Retaining the UUID” on page 57
- “Reading or writing the ECA information” on page 57

Restoring the serial number of the system unit

When the computer was manufactured, the EEPROM on the system board was loaded with the serial numbers of the system and all major components. These numbers need to remain the same throughout the life of the computer.

If you replace the system board, you must restore the serial number of the system unit to its original value.

Before replacing the system board, save the original serial number by doing the following:

1. Install the LENOVO ThinkPad Hardware Maintenance Diskette Version 1.76 or later, and restart the computer.
2. From the main menu, select **1. Set System Identification**.
3. Select **2. Read S/N data from EEPROM**. The serial number of the system unit is listed as: **20: Serial number**.

Write down that number.

Note: The serial number of the system unit also is written on the label attached to the bottom of the computer.

After you have replaced the system board, restore the serial number by doing the following:

1. Install the LENOVO ThinkPad Hardware Maintenance Diskette Version 1.76 or later and restart the computer.
2. From the main menu, select **1. Set System Identification**.
3. Select **1. Add S/N data from EEPROM**. Follow the instructions on the screen.

If the MTM and Product ID numbers differ from each other on the rear label, use what is shown for the Product ID field. See the following example:

MTM on rear label:

TTTT-CTO S/N SSSSSSS

Product ID on rear label:

TTTT-MMM (Use this number when setting Serial Number)

In the example, the Serial Number to be input is “1STTTTMMMSSSSSSS”.

Retaining the UUID

The Universally Unique Identifier (UUID) is a 128-bit number uniquely assigned to your computer at production and stored in the EEPROM of your system board. The algorithm that generates the number is designed to provide unique IDs until the year A.D. 3400. No two computers in the world have the same number.

When you replace the system board, you must set the UUID on the new system board by doing the following:

1. Install the LENOVO ThinkPad Hardware Maintenance Diskette Version 1.76 or later, and restart the computer.
2. From the main menu, select **4. Assign UUID**. A new UUID is created and written. If a valid UUID already exists, it is not overwritten.

Reading or writing the ECA information

Information on Engineering Change Announcements (ECA) are stored in the EEPROM of the system board. The electronic storage of this information simplifies the procedure to check if the ECA has been previously applied to a machine. The machine does not need to be disassembled to check for the ECA application.

To check what ECAs have been previously applied to the machine, use the ECA Information Read/Write function on the LENOVO ThinkPad Hardware Maintenance Diskette Version 1.76 or later.

1. Insert the LENOVO ThinkPad Hardware Maintenance Diskette Version 1.76 or later, and restart the computer.
2. From the main menu, select **6. Set ECA Information**.
3. To read the ECA information, select **2. Read ECA/rework number from EEPROM** and follow the instructions on the screen.
4. To read the box build date, select **5. Read box build date from EEPROM**, and follow the instruction on the screen.

After an ECA has been applied to the machine, the EEPROM must be updated to reflect the ECA's application. Use the LENOVO ThinkPad Hardware Maintenance Diskette Version 1.76 or later to update the EEPROM.

Note: Only the ECA number is stored in the EEPROM. The machine type of the ECA is assumed to be the same as the machine type of the machine that had the ECA applied to it.

1. Insert the LENOVO ThinkPad Hardware Maintenance Diskette Version 1.76 or later, and restart the computer.
2. From the main menu, select **6. Set ECA Information**.
3. To write the ECA information, select **1. Write ECA/rework number from EEPROM**, and follow the instructions on the screen.
4. To write the box build date, select **4. Write box build date from EEPROM**, and follow the instruction on the screen.

If the system board is being replaced, try to read the ECA information from the old system board and transfer the information to the new system. If the system board is inoperable, this will not be possible.

Chapter 9. Removing or replacing a FRU

This chapter provides instructions on how to remove or replace a FRU.

CRU statement for customers:

You can resolve some problems with your product with a replacement part you can install yourself, called a “Customer Replaceable Unit” or “CRU.” Some CRUs are designated as self-service CRUs and others are designated as optional-service CRUs. *Installation of self-service CRUs is your responsibility. For optional-service CRUs, you can either install the CRU yourself or you can request that a Service Provider install the CRU according to the warranty service for your product.* If you intend on installing the CRU, Lenovo will ship the CRU to you. CRU information and replacement instructions are shipped with your product and are available from Lenovo at any time upon request. You can find a list of CRUs for your product in this *Hardware Maintenance Manual*. An electronic version of this manual is available for downloading at <http://www.lenovo.com/suppot>. You might be required to return the defective CRU. When return is required: (1) return instructions, a prepaid shipping label, and a container will be included with the replacement CRU; and (2) you might be charged for the replacement CRU if Lenovo does not receive the defective part within thirty (30) days of your receipt of the replacement CRU. See your Lenovo Limited Warranty documentation for full details.

General guidelines

When removing or replacing a FRU, be sure to observe the following general guidelines:

1. Do not try to service any computer unless you have been trained and certified. An untrained person runs the risk of damaging parts.
2. Before replacing any FRU, review Chapter 8 “FRU replacement notices” on page 55.
3. Begin by removing any FRUs that have to be removed before replacing the failing FRU. Any such FRUs are listed at the beginning of in each FRU replacement section. Remove them in the order in which they are listed.
4. Follow the correct sequence in the steps for removing a FRU, as given in the drawings by the numbers in square callouts.
5. When turning a screw, turn it in the direction as given by the arrow in the drawing.
6. When removing a FRU, move it in the direction as given by the arrow in the drawing.
7. To put the new FRU in place, reverse the removal procedure and follow any notes that pertain to replacement.
8. When replacing a FRU, use the correct screws as shown in the replacement procedures.



DANGER

Before removing any FRU, turn off the computer, unplug all power cords from electrical outlets, remove the battery pack, and then disconnect any interconnecting cables.

Attention: After replacing a FRU, do not turn on the computer until you have made sure that all screws, springs, and other small parts are in place and none are loose inside the computer. Verify this by shaking the computer gently and listening for rattling sounds. Metallic parts or metal flakes can cause electrical short circuits.

Attention: The system board is sensitive to, and can be damaged by, electrostatic discharge. Before touching it, establish personal grounding by touching a ground point with one hand or by using an electrostatic discharge (ESD) strap.

Before servicing the computer

Carefully read this topic before servicing the computer.

Removing the SIM card

Some models you are servicing might have the SIM card that the customer has installed. If the computer you are servicing has the SIM card installed, remove it before you start the servicing.

To remove the SIM card, you need to remove the battery pack first. See “1010 Battery pack” on page 60.

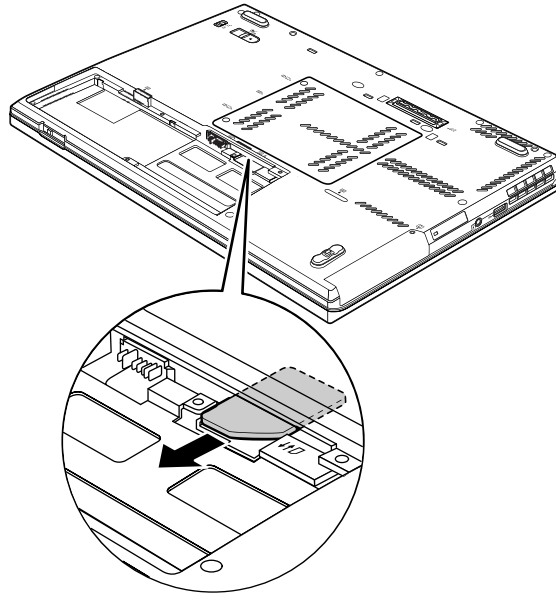

After you finish the servicing, make sure that you insert the card back into the slot firmly.

1010 Battery pack

Important notices for replacing a battery pack:

This system supports only batteries specially designed for this specific system and manufactured by Lenovo or an authorized builder. The system does not support unauthorized batteries or batteries designed for other systems. If an unauthorized battery or a battery designed for another system is installed, the system will not charge.

Attention: Lenovo has no responsibility for the performance or safety of unauthorized batteries, and provides no warranties for failures or damage arising out of their use.

The Lenovo Solution Center program provides an automatic battery diagnostic test that determines if the battery pack is defective. A battery pack FRU should not be replaced unless this diagnostic test shows that the battery is defective. The only exception to this is if the battery pack is physically damaged or a customer is reporting a possible safety issue.

If the Lenovo Solution Center program is not installed in the computer, the customer should download this program before a non-physically damaged battery pack is replaced. Note that the replacement of a physically damaged battery pack is not covered by the warranty.

Removal steps of battery pack



Use only the authorized battery specified for your computer. Any other battery could ignite or explode.

Unlock the battery latch. Hold the battery latch in the unlocked position, and remove the battery pack.

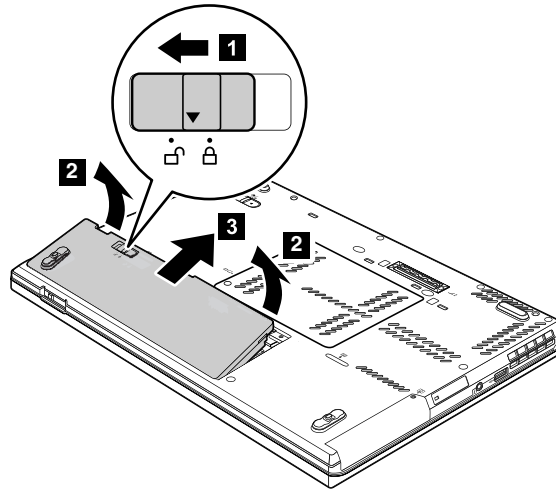

When installing:

Install the battery pack in the slot. Make sure that the battery latch is in the locked position.

1020 Serial Ultrabay Slim device or blank bezel

For access, remove this FRU:

- “1010 Battery pack” on page 60

Removal steps of Serial Ultrabay Slim device or blank bezel

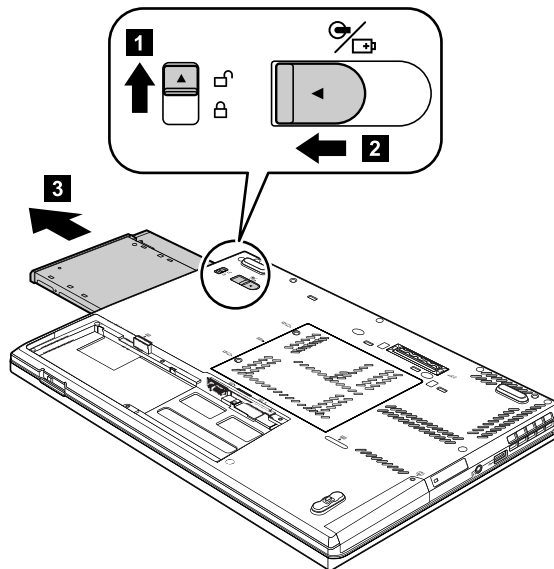

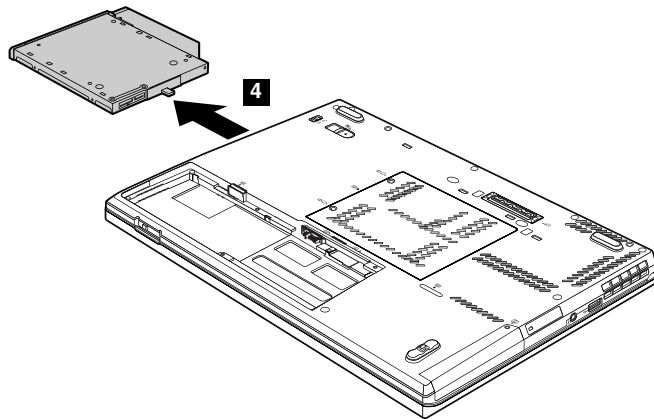

1030 Solid-state drive or hard disk drive

For access, remove this FRU:

- “1010 Battery pack” on page 60

Attention:

- Do not drop the drive or apply any physical shock to it. The drive is sensitive to physical shock. Improper handling can cause damage and permanent loss of data.
- Before removing the drive, have the user make a backup copy of all the information on it if possible.
- Never remove the drive while the system is operating or in suspend mode.

Removal steps of solid-state drive or hard disk drive

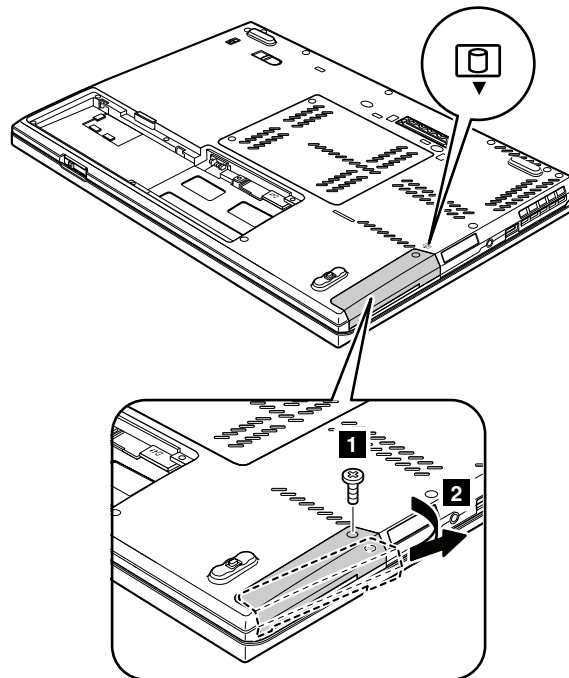

Step	Screw (quantity)	Color	Torque
1	M3 × 3 mm, flat-head, nylon-coated (1)	Black	0.181 Nm (1.85 kgf-cm)

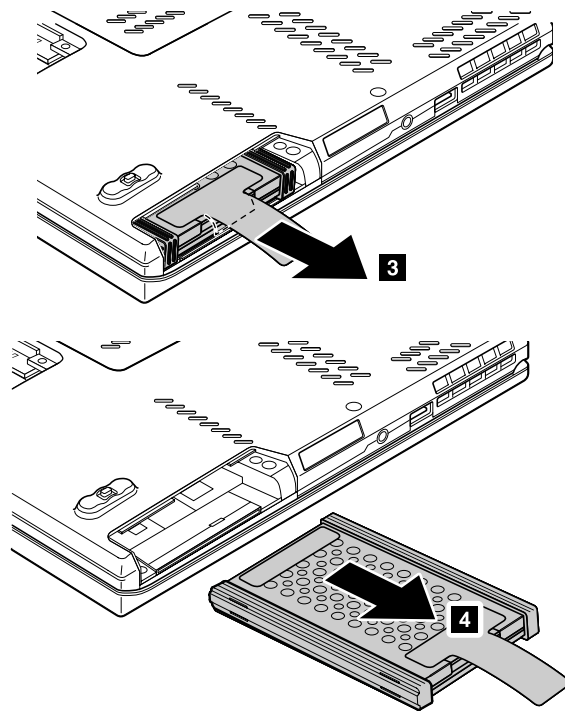

For hard disk drive and rubber rails:

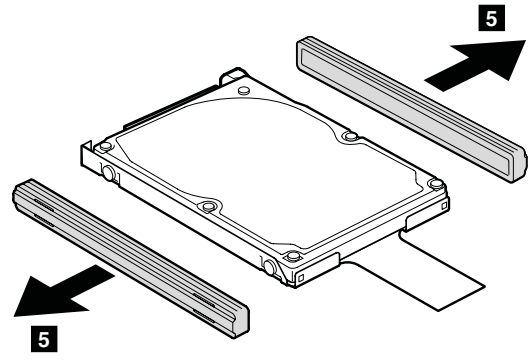

For solid-state drive and spacers:

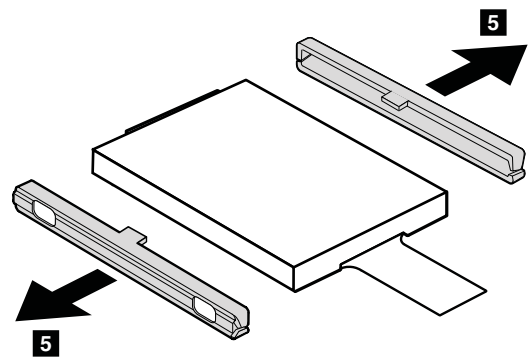

When installing:

Make sure that the solid-state drive or hard disk drive is firmly attached.

1040 Memory module

For access, remove this FRU:

- “1010 Battery pack” on page 60

Removal steps of memory module

Note: Remove the screws **1**.

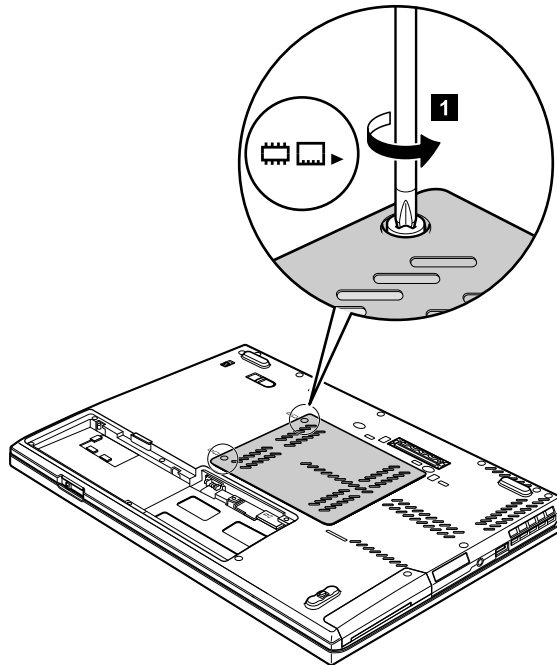

Step	Screw (quantity)	Color	Torque
1	M2 × 5 mm, flat-head, nylon-coated (2)	Black	0.181 Nm (1.85 kgf-cm)

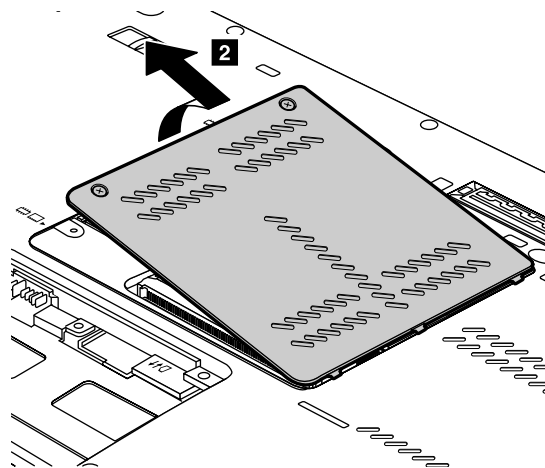

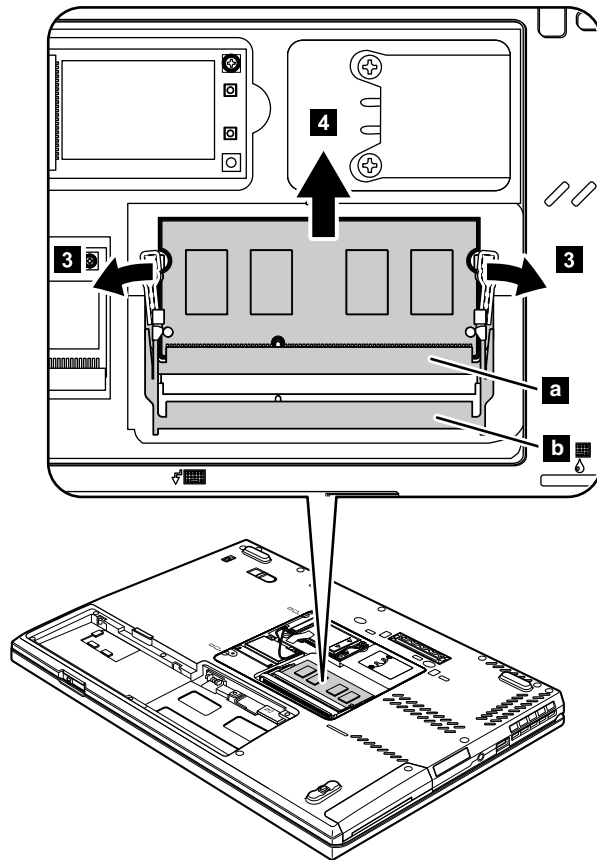

Note: If only one memory module is used on the computer you are servicing, it must be installed in SLOT-0 **a**, but not in SLOT-1 **b**.

When installing:

Insert the notched end of the memory module into the socket. Press the memory module in firmly, and pivot it until it snaps into place. Make sure that it is firmly installed in the slot and does not move easily.

1050 PCI Express Mini Card for wireless LAN

For access, remove this FRU:

- “1010 Battery pack” on page 60

Removal steps of PCI Express Mini Card for wireless LAN

Note: Remove the screws **1**.

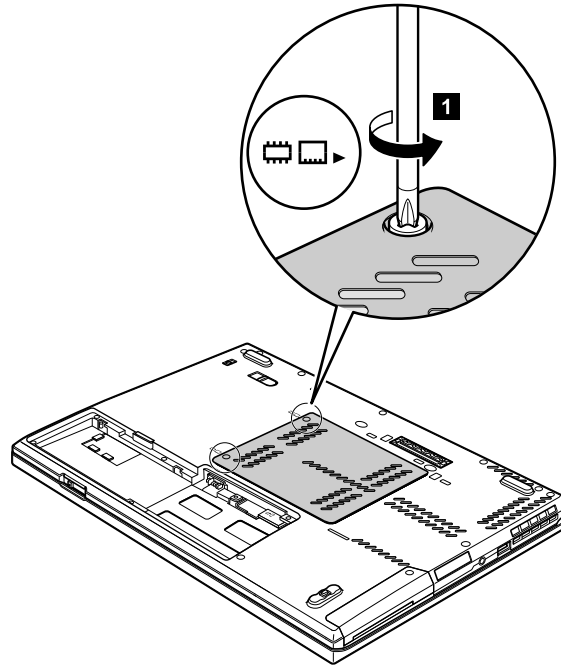

Step	Screw (quantity)	Color	Torque
1	M2 × 5 mm, flat-head, nylon-coated (2)	Black	0.181 Nm (1.85 kgf-cm)

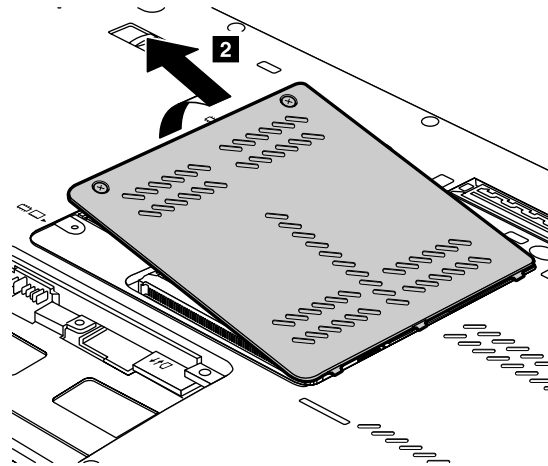

Note: Some models might have only two antenna cables.

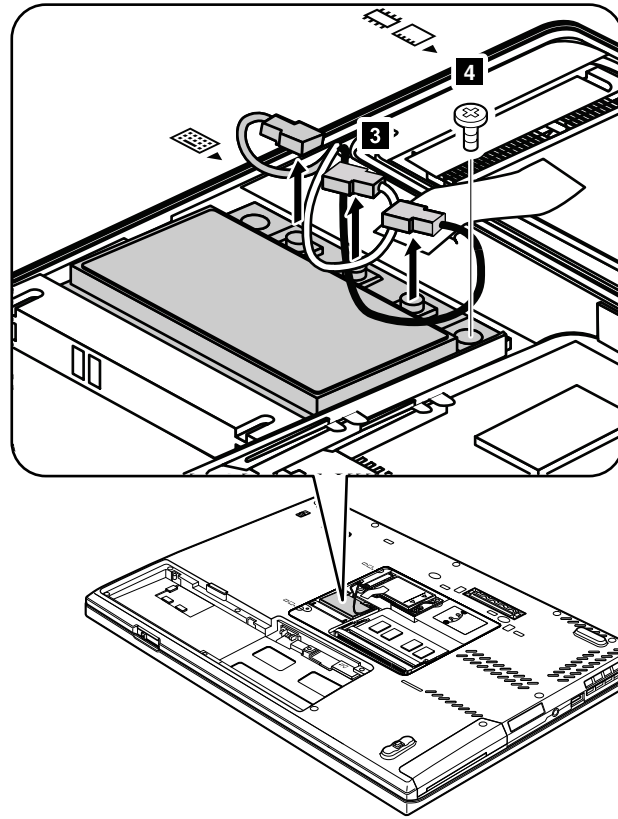

Step	Screw (quantity)	Color	Torque
4	M2 × 3 mm, small-head, nylon-coated (1)	Silver	0.181 Nm (1.85 kgf-cm)

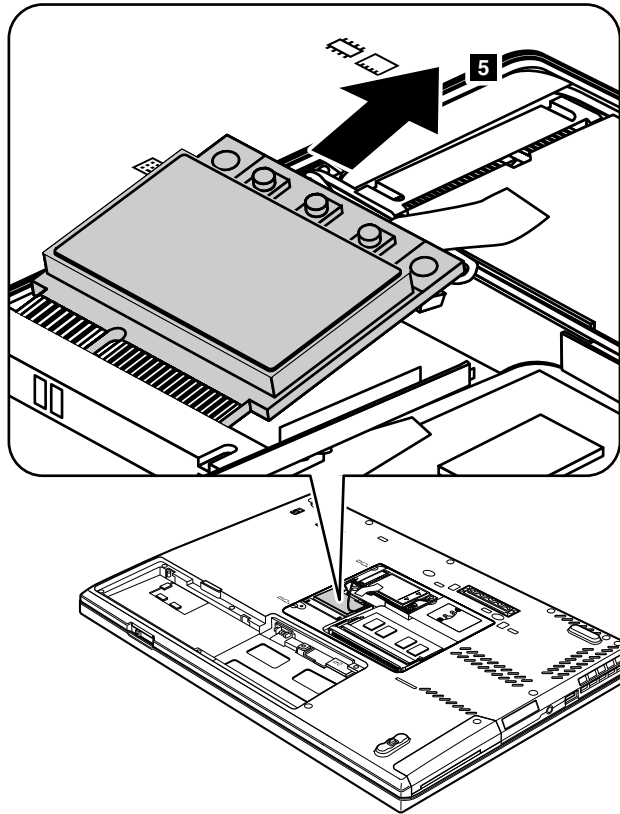

When installing:

- In models with a wireless LAN card that has two antenna connectors, plug the gray cable into the connector labeled **MAIN** or **M**, and the black cable into the connector labeled **AUX** or **A** on the card. If the computer you are servicing has three cables, put the white cable in the cable protection tube.
- In models with a wireless LAN card that has three antenna connectors, plug the gray cable (MAIN) into the connector labeled **TR1**, the white cable (third) into the connector labeled **RO** or **TR3**, and the black cable (AUX) into the connector labeled **TR2** on the card.

1060 PCI Express Mini Card for wireless WAN or mSATA solid-state drive

For access, remove this FRU:

- 1010 Battery pack

The computer you are servicing might come with one of the following cards installed: PCI Express Mini Card for wireless WAN, PCI Express Half Mini Card for wireless WAN, or mSATA solid-state drive.

Removal steps of PCI Express Mini Card for wireless WAN

Note: Remove the screws **1**.

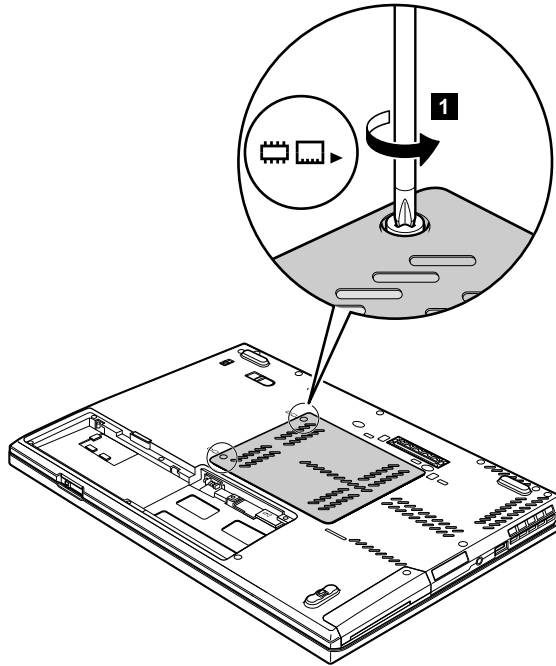

Step	Screw (quantity)	Color	Torque
1	M2 × 5 mm, flat-head, nylon-coated (2)	Black	0.181 Nm (1.85 kgf-cm)

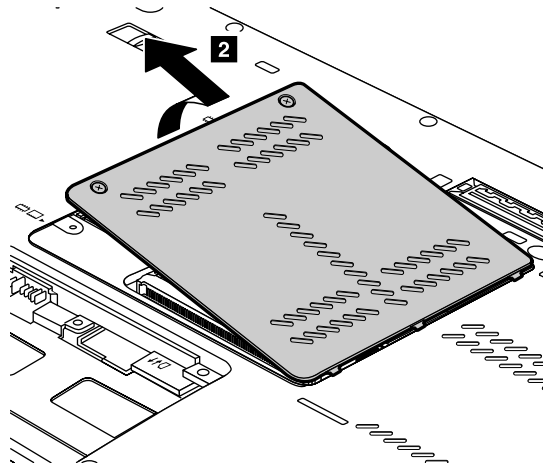

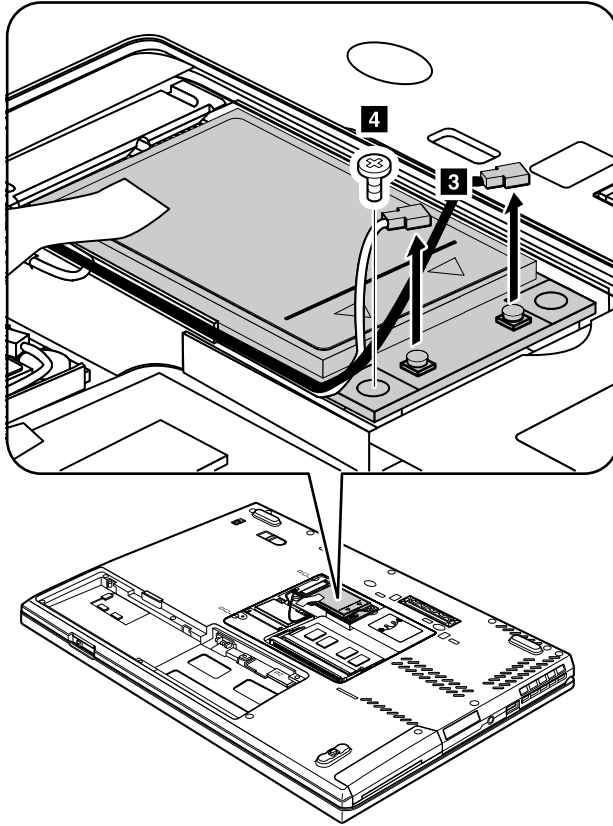

Step	Screw (quantity)	Color	Torque
4	M2 × 3 mm, small-head, nylon-coated (1)	Silver	0.181 Nm (1.85 kgf-cm)

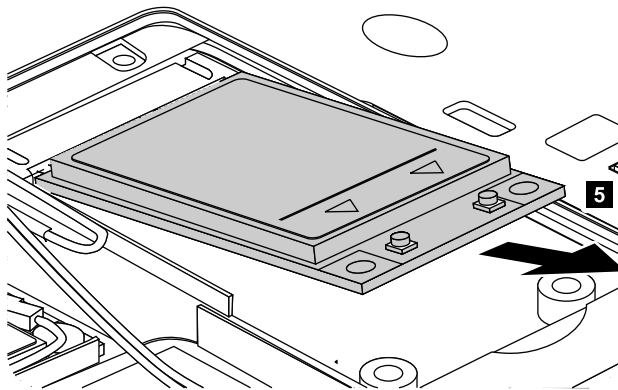

When installing:

Plug the red cable into the connector labeled **MAIN**, and the blue cable into the connector labeled **AUX** on the card.

Removal steps of PCI Express Half Mini Card for wireless WAN

Note: Remove the screws **4**.

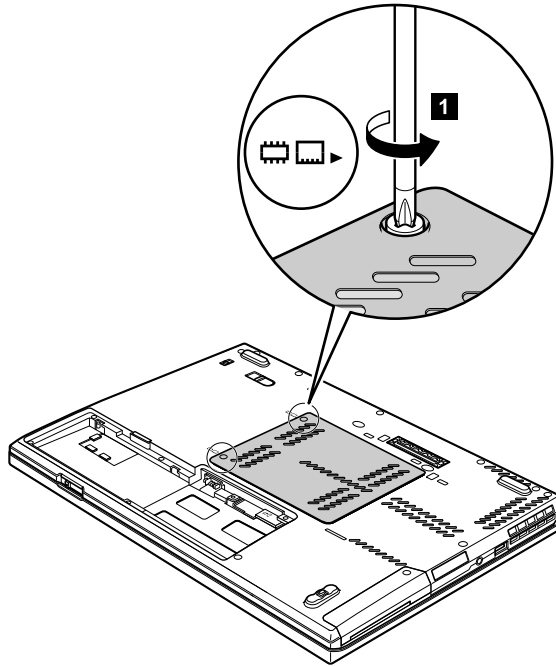

Step	Screw (quantity)	Color	Torque
1	M2 × 5 mm, flat-head, nylon-coated (2)	Black	0.181 Nm (1.85 kgf-cm)

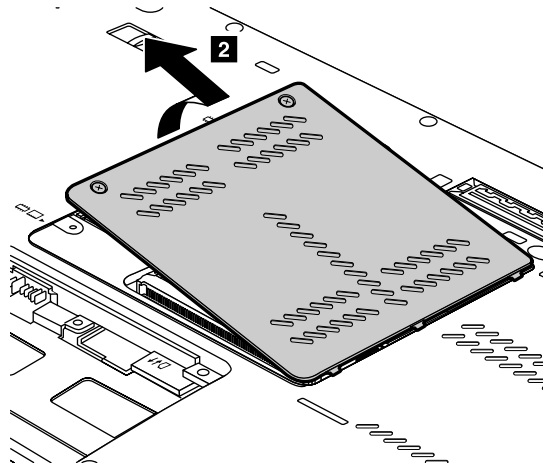

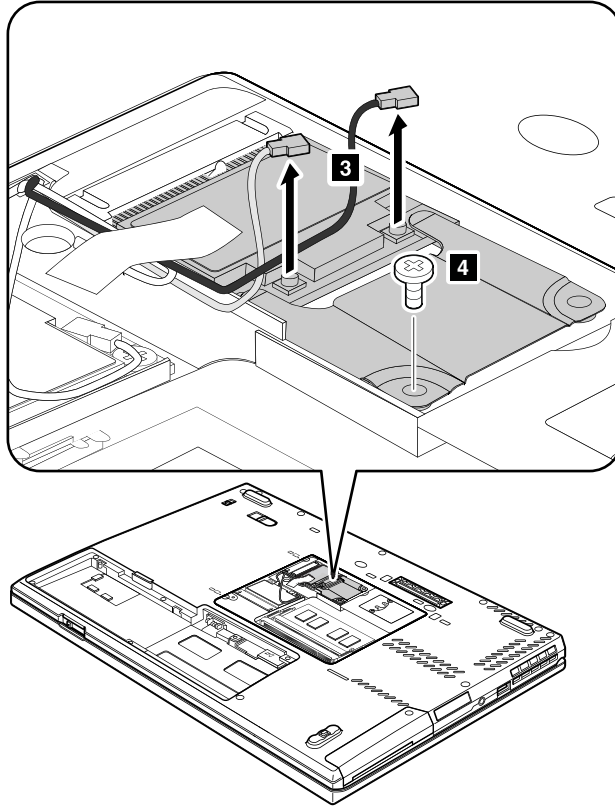

Step	Screw (quantity)	Color	Torque
4	M2 × 3 mm, small-head, nylon-coated (1)	Silver	0.181 Nm (1.85 kgf-cm)

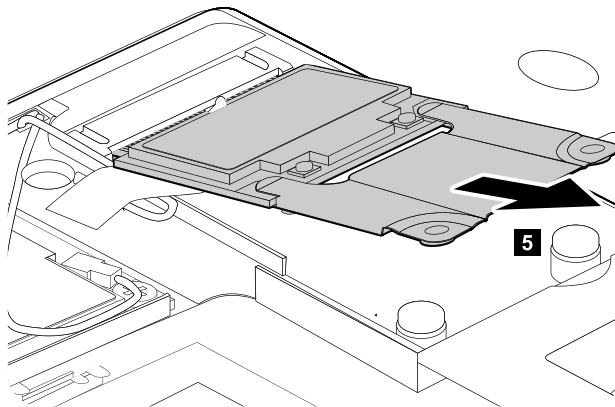

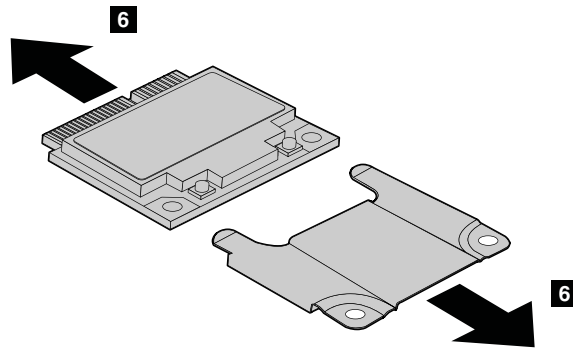

When installing:

Plug the red cable into the connector labeled **MAIN**, and the blue cable into the connector labeled **AUX** on the card.

Removal steps of mSATA solid-state drive

The computer comes with either a PCI Express Mini Card for wireless WAN or an mSATA solid-state drive. If the computer is equipped with an mSATA solid-state drive, it is installed in the wireless WAN card slot.

Attention:

- Do not drop the drive or apply any physical shock to it. The drive is sensitive to physical shock. Improper handling can cause damage and permanent loss of data.
- Before removing the drive, have the user make a backup copy of all the information on it if possible.
- Never remove the drive while the computer is operating or in suspend mode.
- Ensure that you partition the mSATA solid-state drive after installing it on the computer you are servicing. Otherwise, the mSATA solid-state drive will not function correctly. For instructions on how to partition an mSATA solid-state drive, go to <http://www.lenovo.com/support/msata-fru>.

Note: Remove the screws **1**.

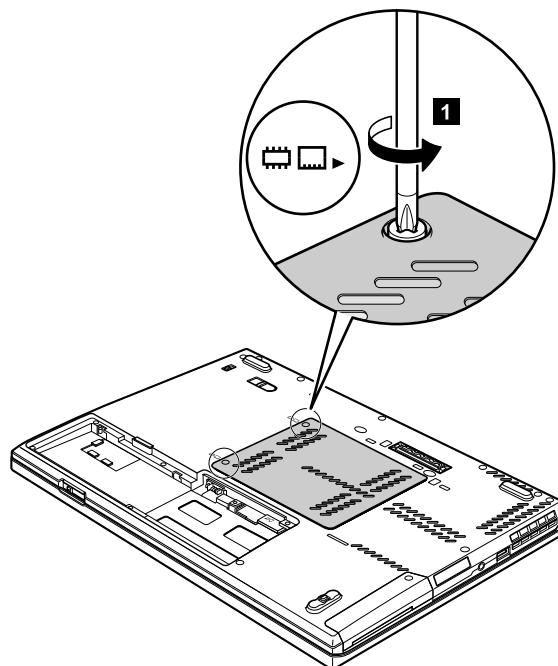

Step	Screw (quantity)	Color	Torque
1	M2 × 5 mm, flat-head, nylon-coated (2)	Black	0.181 Nm (1.85 kgf-cm)

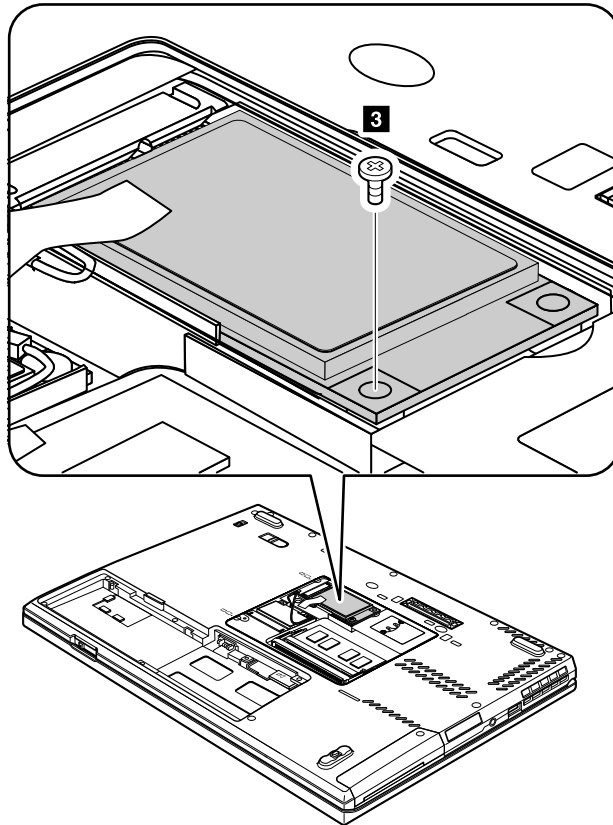
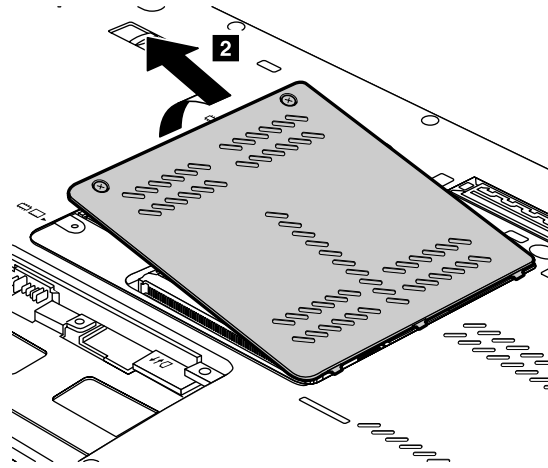

Step	Screw (quantity)	Color	Torque
3	M2 × 3 mm, small-head, nylon-coated (1)	Silver	0.181 Nm (1.85 kgf-cm)

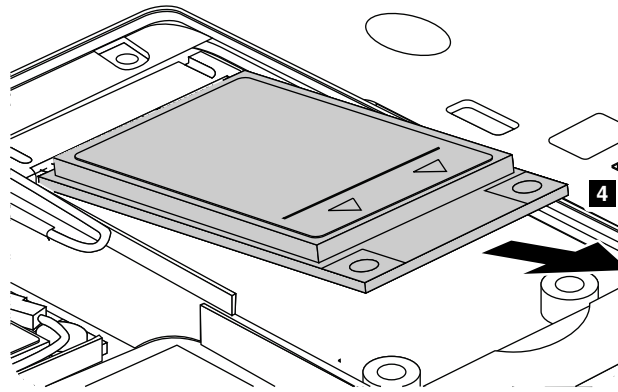

1070 4-in-1 media card reader or ExpressCard reader

For access, remove this FRU:

- “1010 Battery pack” on page 60

Note: The computer you are servicing might have a 4-in-1 media card reader or ExpressCard reader.

Removal steps of 4-in-1 media card reader or ExpressCard reader

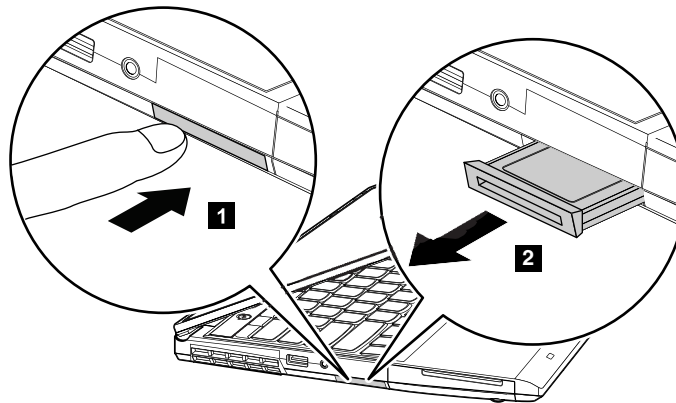

1080 Keyboard

For access, remove this FRU:

- “1010 Battery pack” on page 60

Removal steps of keyboard

Note: Remove the screws **1**.

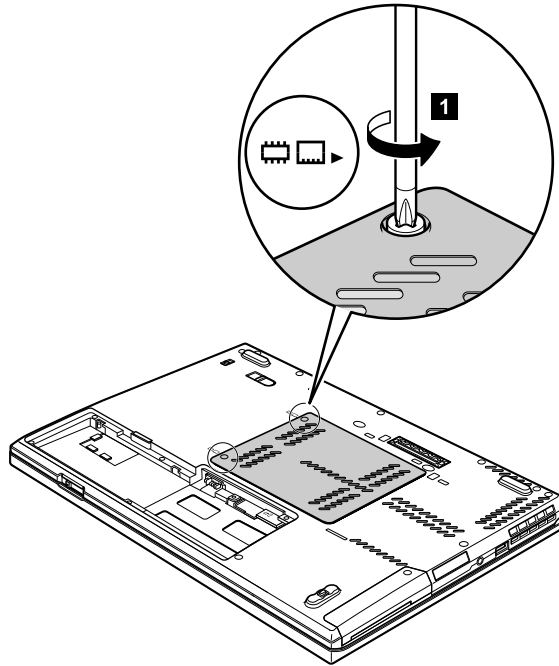

Step	Screw (quantity)	Color	Torque
1	M2 × 5 mm, flat-head, nylon-coated (2)	Black	0.181 Nm (1.85 kgf-cm)

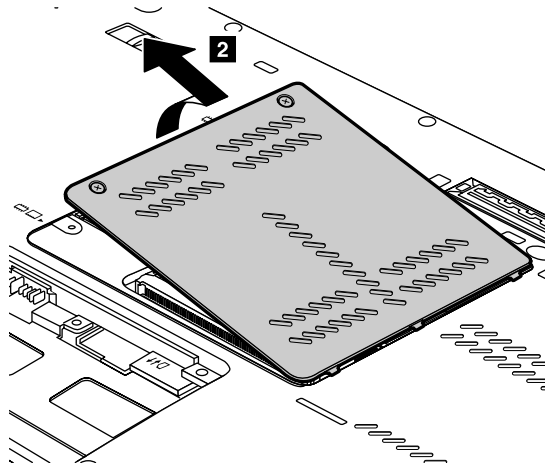

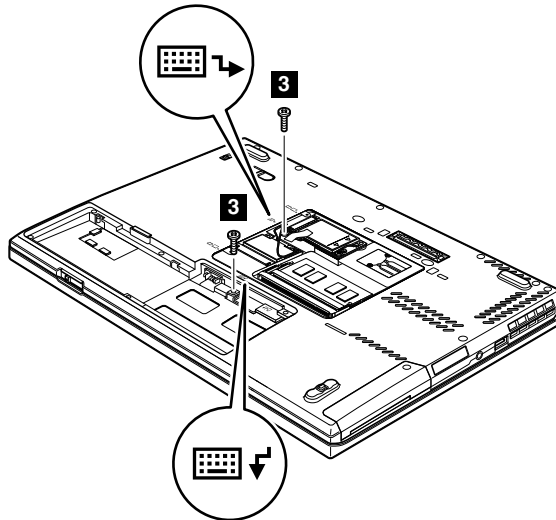

Step	Screw (quantity)	Color	Torque
3	M2 × 5 mm, flat-head, nylon-coated (2)	Black	0.181 Nm (1.85 kgf-cm)

Slightly press the keyboard and slide it a little bit forward, in the direction shown by the arrows **4**, to detach the rear edge of the keyboard from the frame. Then, lift up the keyboard in the direction shown by the arrows **5**.

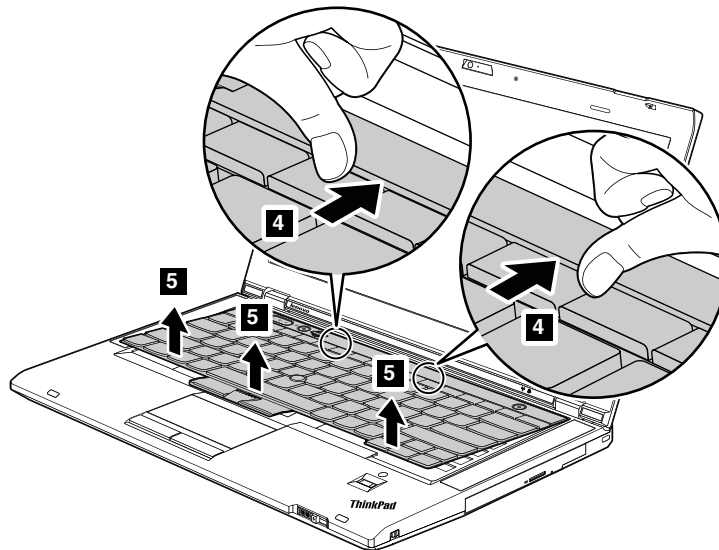

Lift the keyboard in the direction shown by the arrow **6**, and then detach the connector **7**.

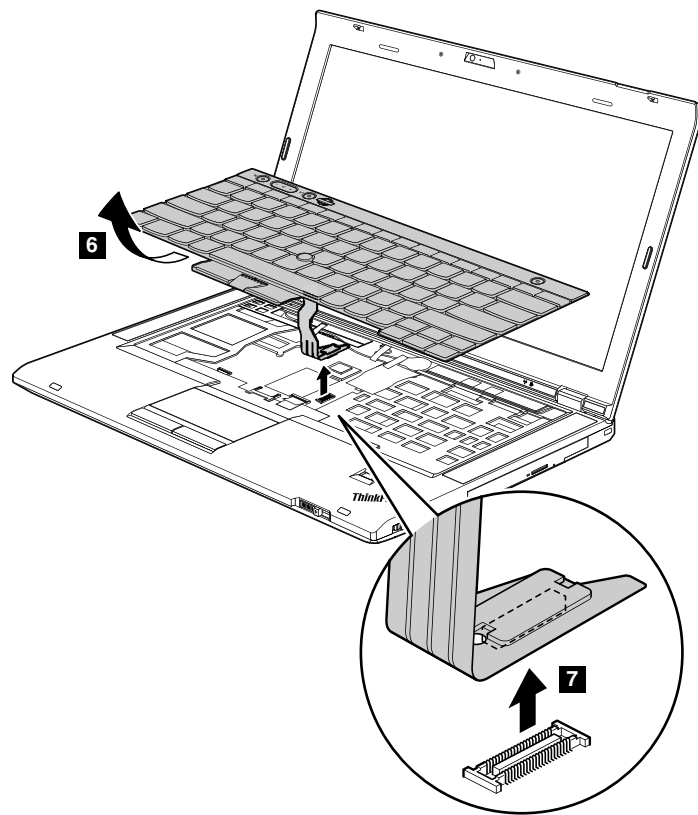

Installation steps of keyboard

When installing the keyboard, do the following:

1. Attach the keyboard connector.

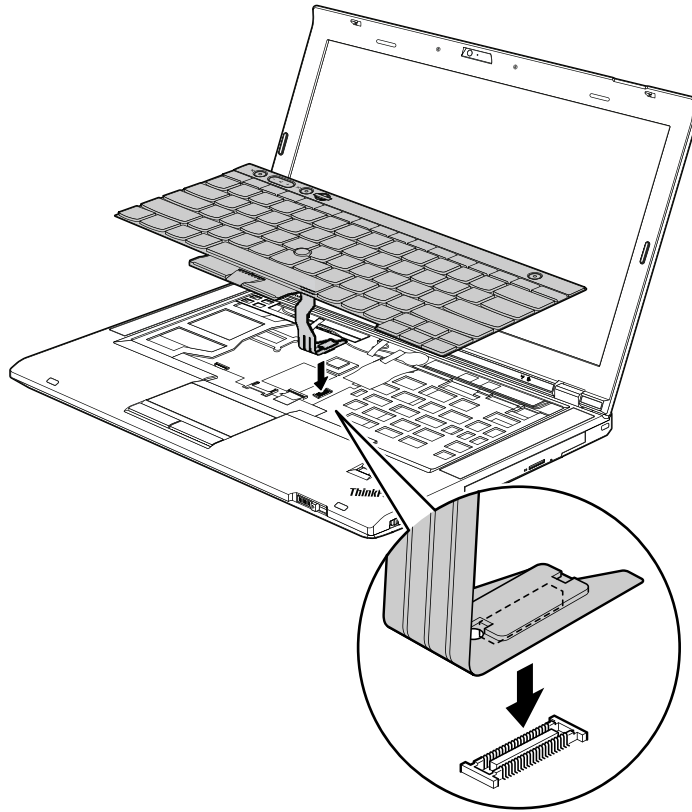

2. Attach the keyboard and ensure that the hooks **a** on the front edge of the keyboard are under the frame.

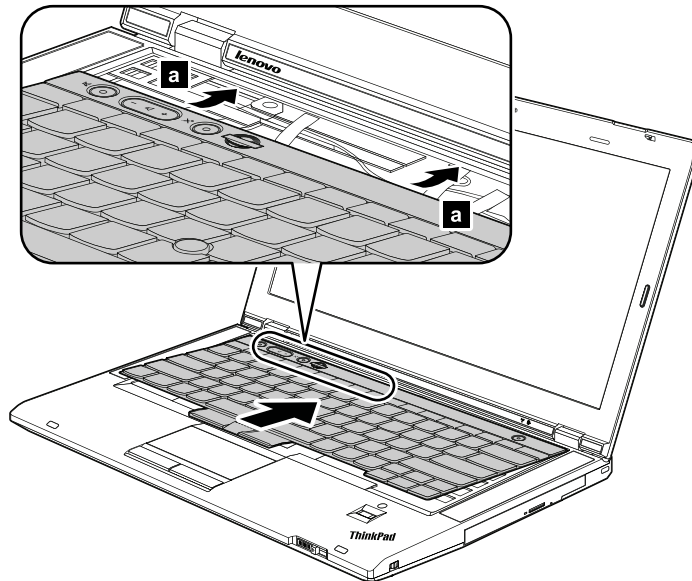

3. Gently press the keys with your palms and slightly slide the keyboard towards you until it snaps into position.

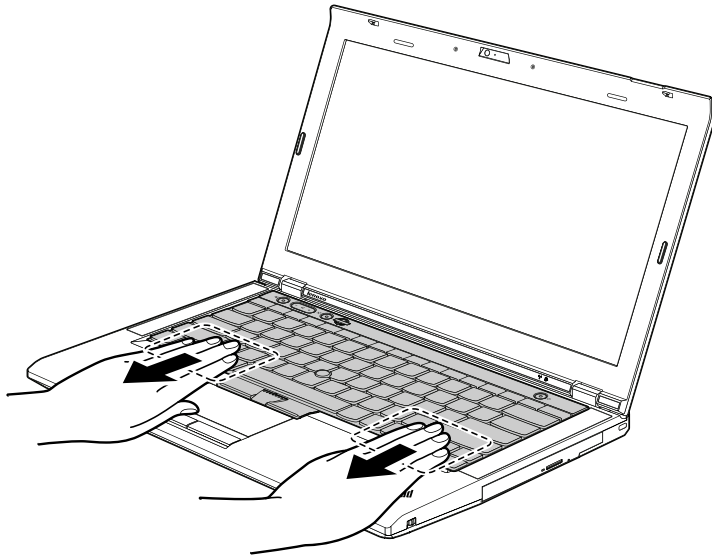

4. Secure the keyboard by tightening the screws from the bottom side of the computer.

1090 Backup battery

For access, remove these FRUs in order:

- “1010 Battery pack” on page 60
- “1080 Keyboard” on page 75



Use only the authorized battery specified for your computer. Any other battery could ignite or explode.

Removal steps of backup battery

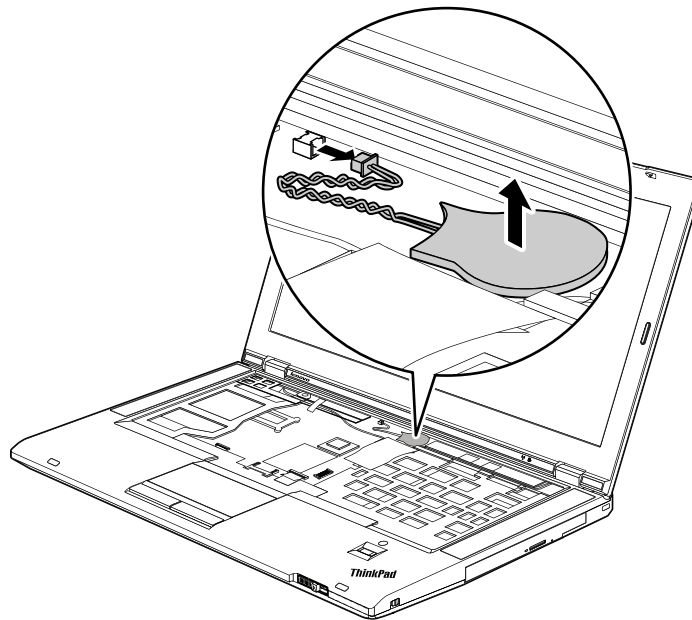

When installing:

Attach the backup battery **a** in the insulation sheet and make sure that the battery connector is attached firmly.

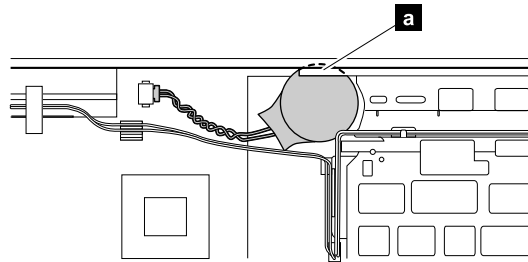

1100 Keyboard bezel assembly with fingerprint reader, smart card reader, and speaker assembly

For access, remove these FRUs in order:

- “1010 Battery pack” on page 60
- “1030 Solid-state drive or hard disk drive” on page 62
- “1080 Keyboard” on page 75

Note: In models with the fingerprint reader, the fingerprint reader sensor is attached to the keyboard bezel assembly. If the fingerprint reader is defective, you can replace the keyboard bezel assembly by following the procedures in this section. The replacement procedures are the same for a keyboard bezel assembly with or without a fingerprint reader.

Removal steps of keyboard bezel with fingerprint reader

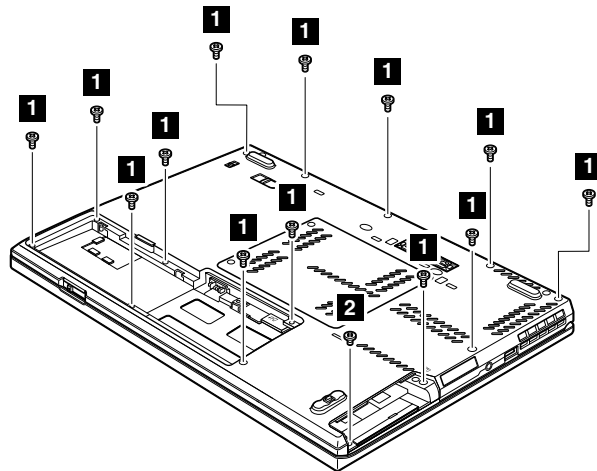

Step	Screw (quantity)	Color	Torque
1	M2 × 5 mm, flat-head, nylon-coated (13)	Black	0.181 Nm (1.85 kgf-cm)
2	M2 × 3 mm, flat-head, nylon-coated (1)	Silver	0.181 Nm (1.85 kgf-cm)

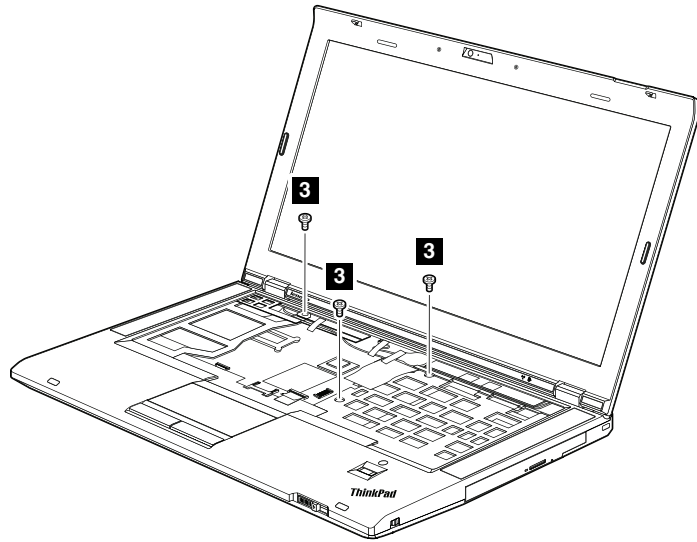

Step	Screw (quantity)	Color	Torque
3	M2 × 5 mm, flat-head, nylon-coated (3)	Black	0.181 Nm (1.85 kgf-cm)

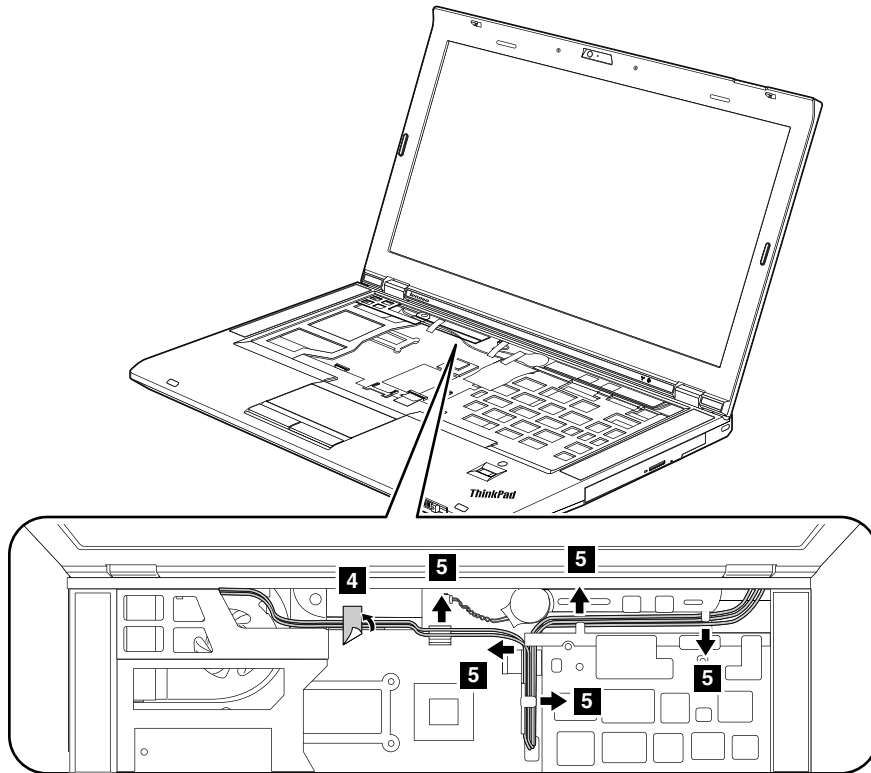

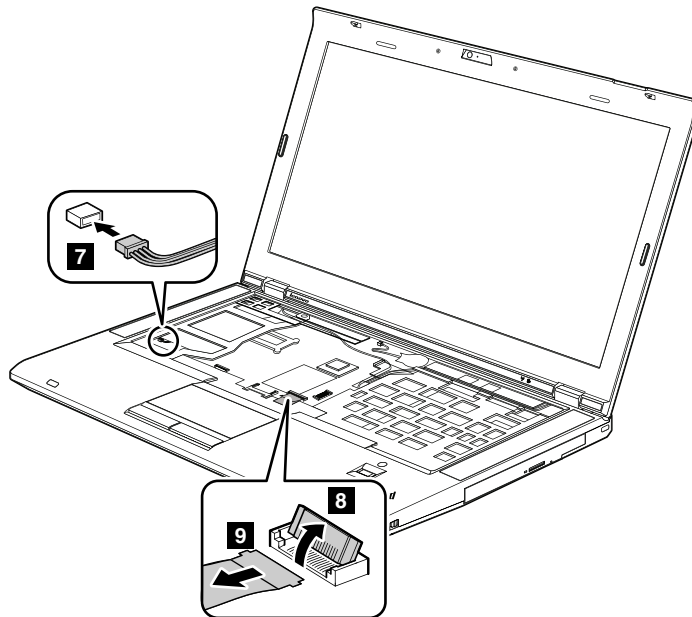
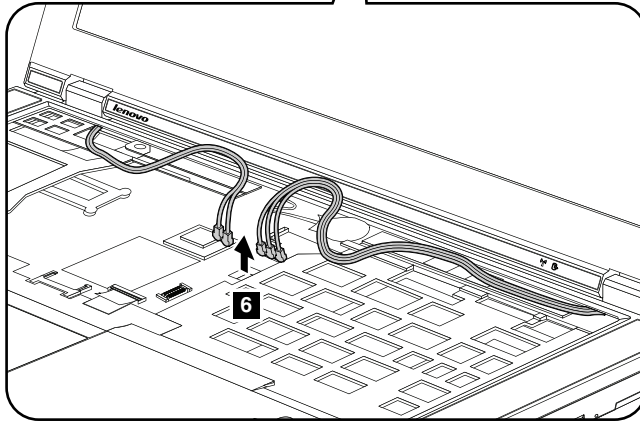
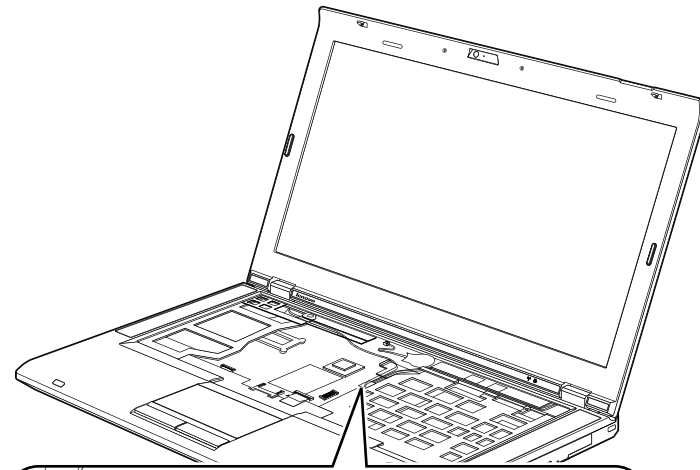

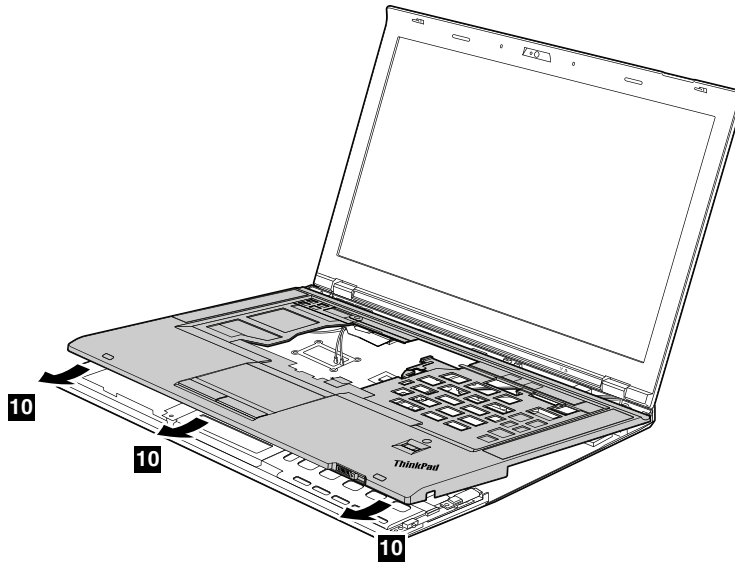

Removal steps of smart card reader

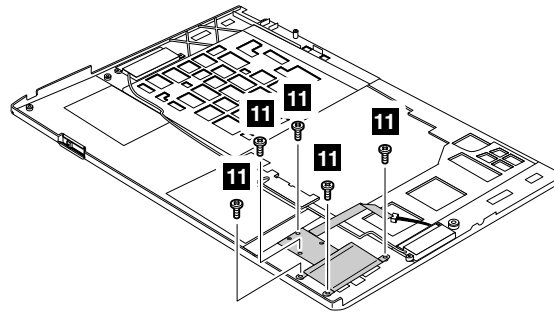

Step	Screw (quantity)	Color	Torque
11	M2 × 3 mm, flat-head, nylon-coated (5)	Silver	0.181 Nm (1.85 kgf-cm)

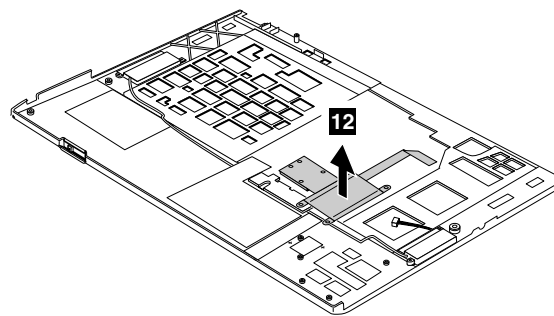

Removal steps of speaker assembly

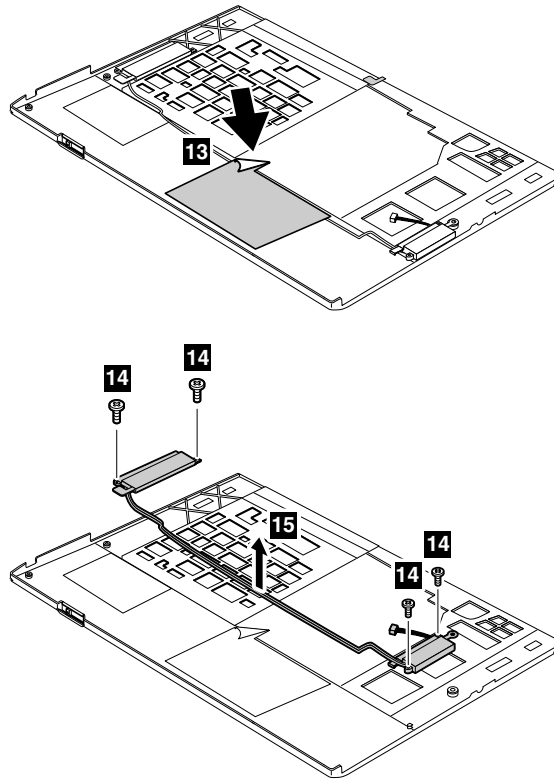

Step	Screw (quantity)	Color	Torque
14	M2 × 3 mm, flat-head, nylon-coated (4)	Silver	0.181 Nm (1.85 kgf-cm)

1110 LCD unit

For access, remove these FRUs in order:

- “1010 Battery pack” on page 60
- “1020 Serial Ultrabay Slim device or blank bezel” on page 61
- “1030 Solid-state drive or hard disk drive” on page 62
- “1040 Memory module” on page 64
- “1050 PCI Express Mini Card for wireless LAN” on page 65
- “1060 PCI Express Mini Card for wireless WAN or mSATA solid-state drive” on page 68
- “1080 Keyboard” on page 75
- “1100 Keyboard bezel assembly with fingerprint reader, smart card reader, and speaker assembly” on page 81

Removal steps of LCD unit

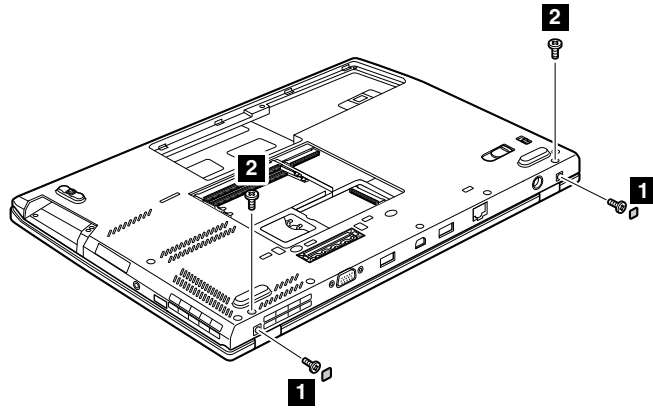

Step	Screw cap	Screw (quantity)	Color	Torque
1		M2.5 × 5 mm, flat-head, nylon-coated (2)	Black	0.392 Nm (4.0 kgf-cm)
2		M2.5 × 5 mm, flat-head, nylon-coated (2)	Black	0.392 Nm (4.0 kgf-cm)

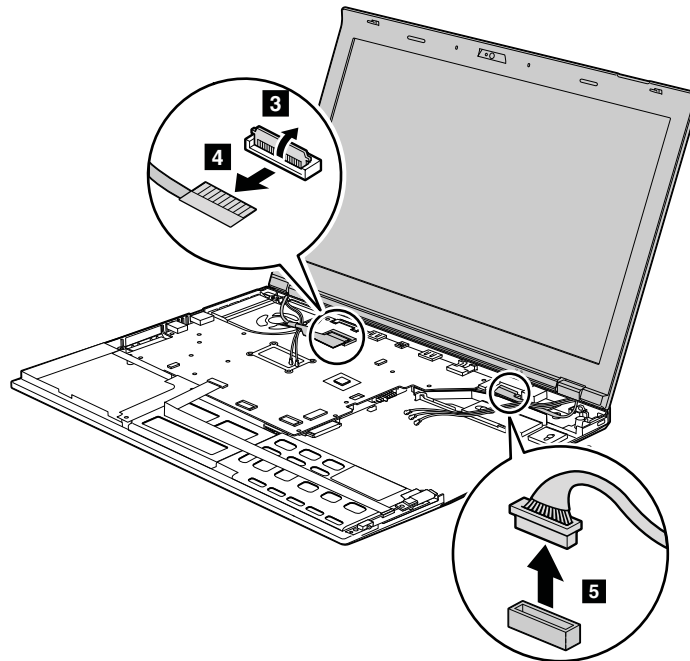

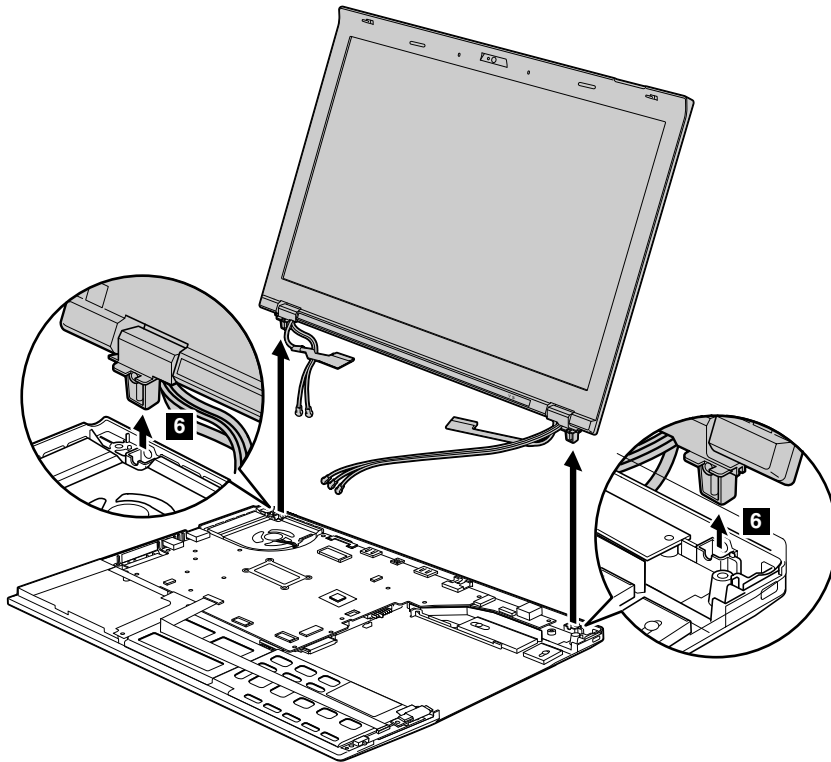

When installing

- Make sure that you route the cables firmly and tape up in the proper positions as shown in the illustration above.
- When you route the cables, make sure that they are not subject to any tension. Tension could cause the cables to be damaged by the cable guides, or a wire to be broken.

1120 DC-in sub card

For access, remove these FRUs in order:

- “1010 Battery pack” on page 60
- “1020 Serial Ultrabay Slim device or blank bezel” on page 61
- “1030 Solid-state drive or hard disk drive” on page 62
- “1040 Memory module” on page 64
- “1050 PCI Express Mini Card for wireless LAN” on page 65
- “1060 PCI Express Mini Card for wireless WAN or mSATA solid-state drive” on page 68
- “1080 Keyboard” on page 75
- “1100 Keyboard bezel assembly with fingerprint reader, smart card reader, and speaker assembly” on page 81
- “1110 LCD unit” on page 85

Removal steps of DC-in sub card

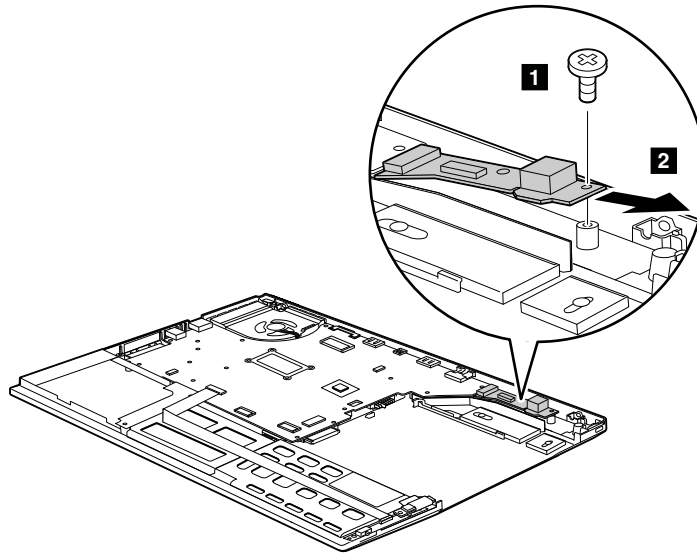

Step	Screw (quantity)	Color	Torque
1	M2 × 3 mm, shoulder-socket head, nylon-coated (1)	Silver	0.181 Nm (1.85 kgf-cm)

1130 Bluetooth daughter card (BDC-4.0)

For access, remove these FRUs in order:

- “1010 Battery pack” on page 60
- “1030 Solid-state drive or hard disk drive” on page 62
- “1080 Keyboard” on page 75
- “1100 Keyboard bezel assembly with fingerprint reader, smart card reader, and speaker assembly” on page 81
- “1110 LCD unit” on page 85

Removal steps of BDC-4.0

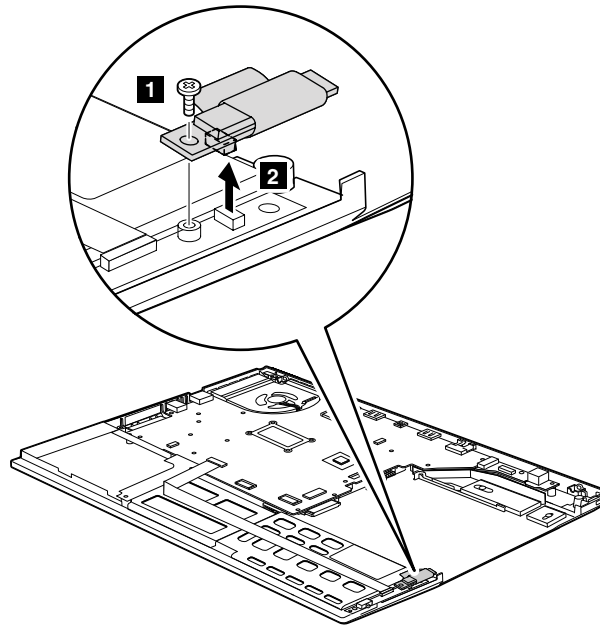

Step	Screw (quantity)	Color	Torque
1	M2 × 4 mm, flat-head, nylon-coated (1)	Black	0.181 Nm (1.85 kgf-cm)

When installing:

Make sure that the connector is attached firmly.

1140 Bluetooth wireless radio switch FPC

For access, remove these FRUs in order:

- “1010 Battery pack” on page 60
- “1020 Serial Ultrabay Slim device or blank bezel” on page 61
- “1030 Solid-state drive or hard disk drive” on page 62
- “1040 Memory module” on page 64
- “1050 PCI Express Mini Card for wireless LAN” on page 65
- “1060 PCI Express Mini Card for wireless WAN or mSATA solid-state drive” on page 68
- “1070 4-in-1 media card reader or ExpressCard reader” on page 75
- “1080 Keyboard” on page 75
- “1100 Keyboard bezel assembly with fingerprint reader, smart card reader, and speaker assembly” on page 81
- “1110 LCD unit” on page 85
- “1130 Bluetooth daughter card (BDC-4.0)” on page 88

Removal steps of Bluetooth wireless radio switch FPC

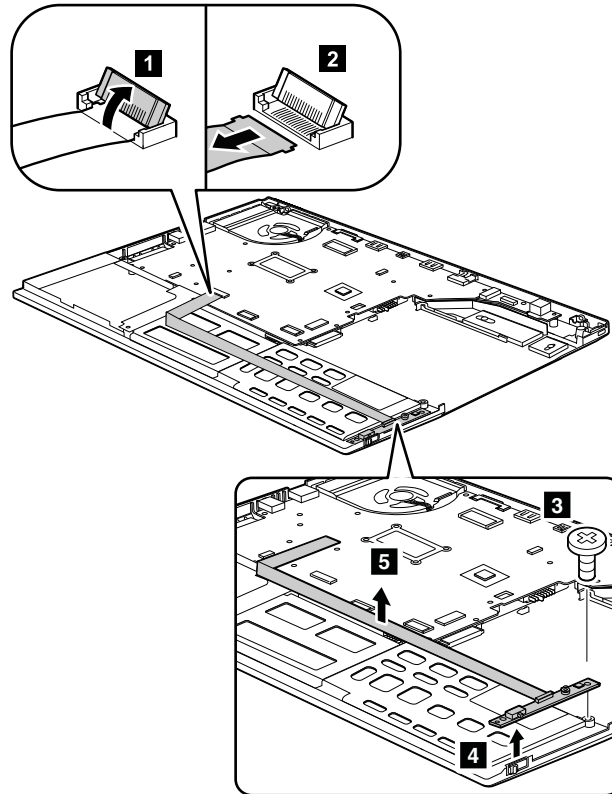

Step	Screw (quantity)	Color	Torque
3	M2 × 3 mm, bind-head, nylon-coated (1)	Silver	0.181 Nm (1.85 kgf-cm)

When installing:

Attach the Bluetooth wireless radio switch as shown in the following illustration **a**.

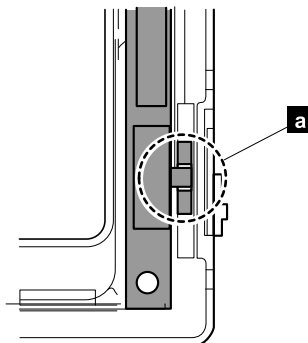

1150 System board, thermal fan assembly, 34-mm ExpressCard reader, and base cover

Important notices for handling the system board:

When handling the system board, read the following:

- The system board has an accelerometer, which can be broken when several thousands of G-forces are applied.

Note: Dropping a system board from a height of as little as 6 inches so that it falls flat on a hard bench can subject the accelerometer to as much as 6,000 G's of shock.

- Be careful not to drop the system board on a bench top that has a hard surface, such as metal, wood, or composite.
- Avoid rough handling of any kind.
- At every point in the process, be sure not to drop or stack the system board.
- If you put a system board down, be sure to put it only on a padded surface such as an ESD mat or a corrugated conductive material.

For access, remove these FRUs in order:

- “1010 Battery pack” on page 60
- “1020 Serial Ultrabay Slim device or blank bezel” on page 61
- “1030 Solid-state drive or hard disk drive” on page 62
- “1040 Memory module” on page 64
- “1050 PCI Express Mini Card for wireless LAN” on page 65
- “1060 PCI Express Mini Card for wireless WAN or mSATA solid-state drive” on page 68
- “1070 4-in-1 media card reader or ExpressCard reader” on page 75
- “1080 Keyboard” on page 75
- “1100 Keyboard bezel assembly with fingerprint reader, smart card reader, and speaker assembly” on page 81
- “1110 LCD unit” on page 85
- “1120 DC-in sub card” on page 87
- “1140 Bluetooth wireless radio switch FPC” on page 89

Removal steps of system board, thermal fan assembly, 34-mm ExpressCard reader, and base cover

The following components soldered on the top side of the system board are extremely sensitive. When you service the system board, avoid any kind of rough handling.

- a** Graphic Processing Unit (GPU)

Note: The GPU is only available on models that have a discrete graphics card.

- b** Microprocessor

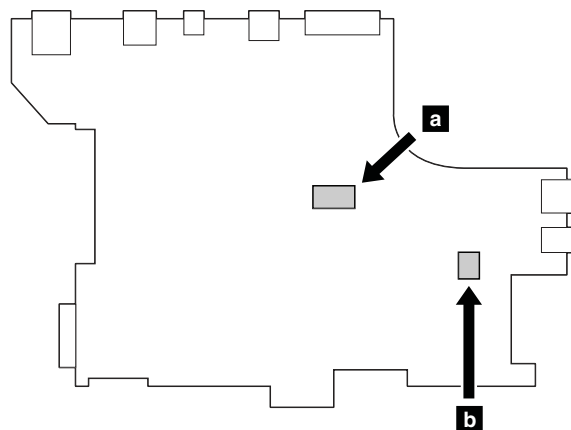

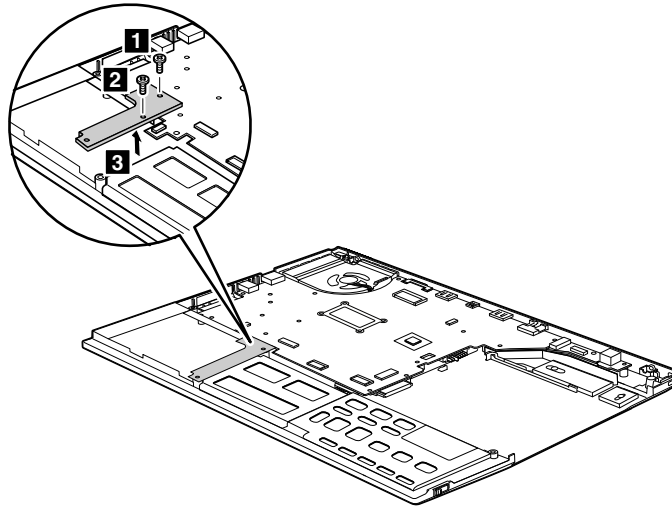

Step	Screw (quantity)	Color	Torque
1	M 2 × 9 mm, flat head, nylon-coated (1)	Black	0.181 Nm (1.85 kgf-cm)
2	M2 × 3 mm, flat head, nylon-coated (1)	Silver	0.181 Nm (1.85 kgf-cm)

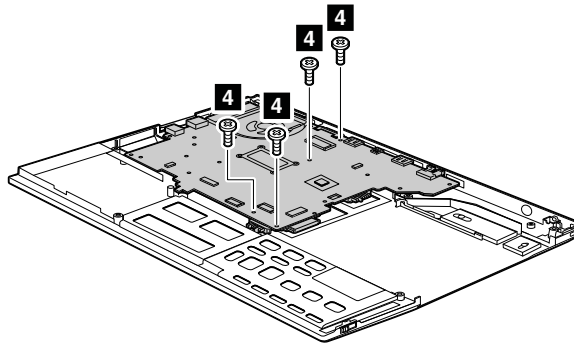

Step	Screw (quantity)	Color	Torque
4	M2 × 5 mm, big-head, nylon-coated (4)	Black	0.181 Nm (1.85 kgf-cm)

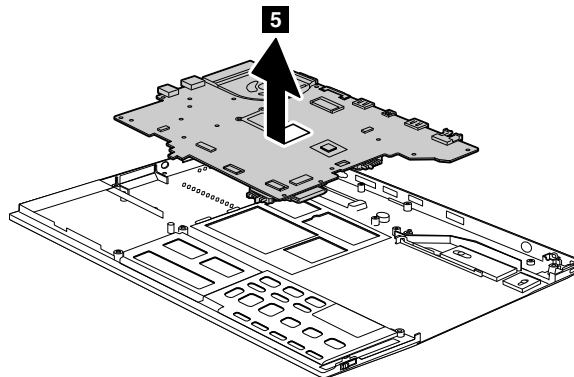

In step **5**, remove the system board with thermal fan assembly together from the base cover assembly.

Turn the system board over, and then disconnect the thermal fan assembly from the system board.

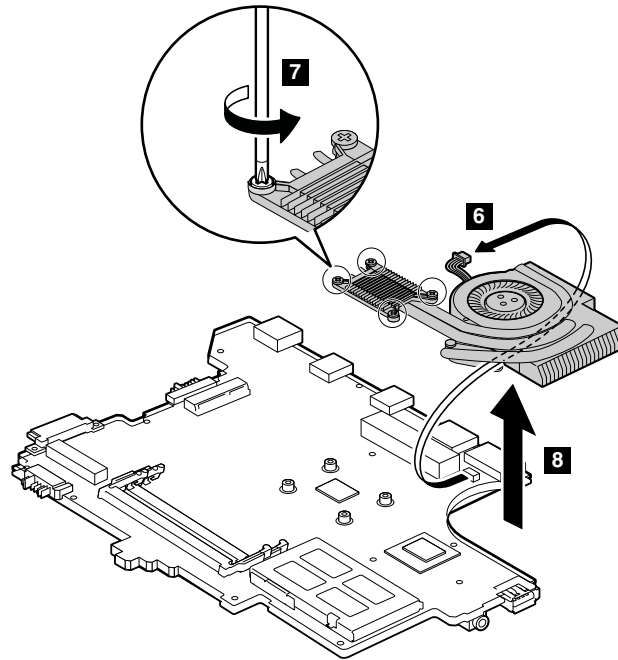

Step	Screw (quantity)	Color	Torque
7	M2 × 5 mm, big-head, nylon-coated (4)	Black	0.181 Nm (1.85 kgf-cm)

When installing:

- Before you attach the thermal fan assembly to the computer, apply thermal grease, at an amount of 0.2 grams, on the part marked **a** as in the following illustration. Either too much or too less application of grease can cause a thermal problem due to imperfect contact with a component. You need to peel the thin film off from the rubber **b**.
- Make sure that the fan connector is attached firmly.

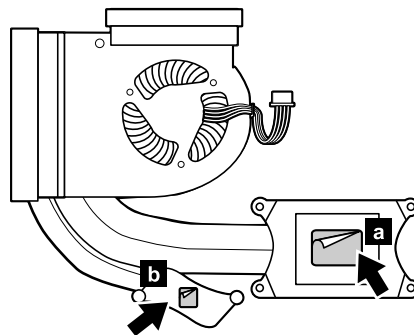

Remove the three screws and then remove the 34-mm ExpressCard reader from the system board.

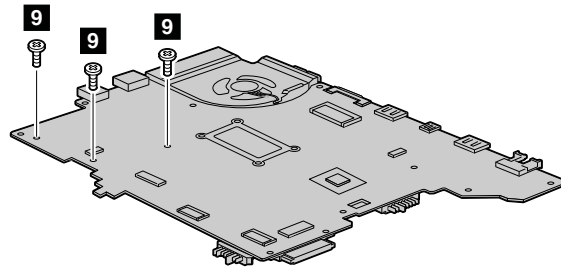

Step	Screw (quantity)	Color	Torque
9	M2 × 3 mm, flat-head, nylon-coated (3)	Silver	0.181 Nm (1.85 kgf-cm)

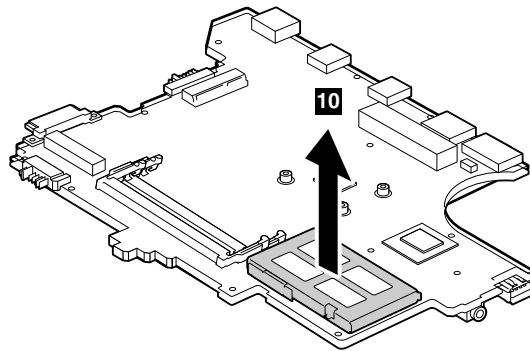

Applying labels to the base cover:

The new base cover FRU is shipped with a kit containing labels of several kinds. Apply those labels when you replace the base cover. For the labels which are not shipped with the new base cover, peel them from the old base cover, and adhere them to the new one.

The following illustration shows the location of each label.

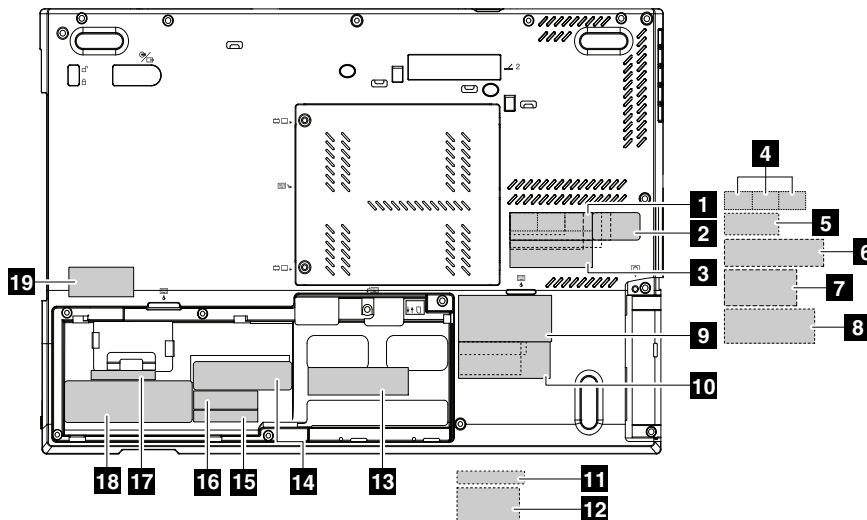

Note: If the Windows Certificate of Authentication (COA) label **18** is attached to a part that is replaced, return the old part with the label attached to the customer, or provide a letter to the customer stating what the label was originally on the computer and what the label part number, serial number, and product key were.

When you replace the base cover, apply the following labels:

- 13** Serial number label
- 15** FCC label

The following labels need to be peeled off from the old base cover, and need to be put on the new base cover.

- 1** Brazil wireless card label
- 2** Brazil WWAN label
- 3** Brazil Bluetooth label
- 4** SIRIM label or Indonesia POSTEL label
- 5** China WWAN label
- 6** Non-encryption label or Indonesia rating label
- 7** China 3G WWAN label
- 8** Israel label
- 9** Asset tag
- 10** China Telecom label
- 11** Ericsson WWAN label
- 12** IMEI/ESN label
- 14** System label
- 16** GEO label
- 17** GEO label for Taiwan and Korea
- 18** COA label
- 19** GEO label for China

2010 LCD bezel assembly

For access, remove this FRU:

- “1010 Battery pack” on page 60

Removal steps of LCD bezel assembly

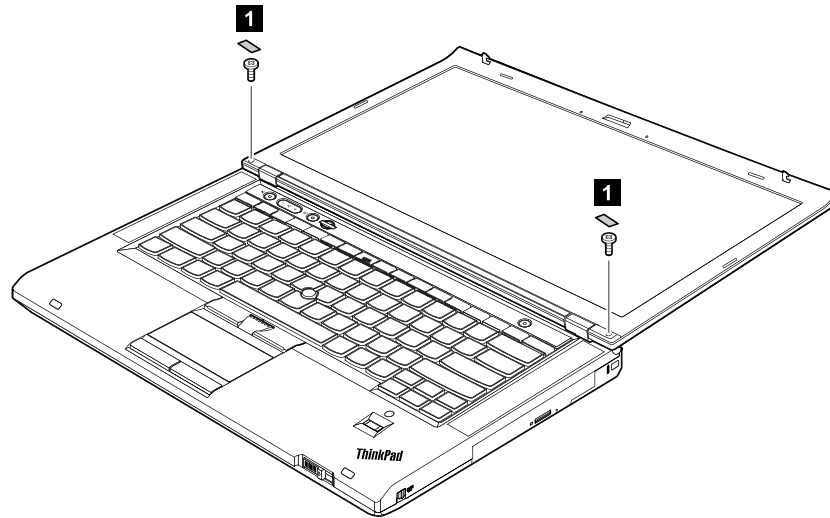

Step	Screw cap	Screw (quantity)	Color	Torque
1		M2 x 5 mm, shoulder-socket head, nylon-coated (2)	Black	0.181 Nm (1.85 kgf-cm)

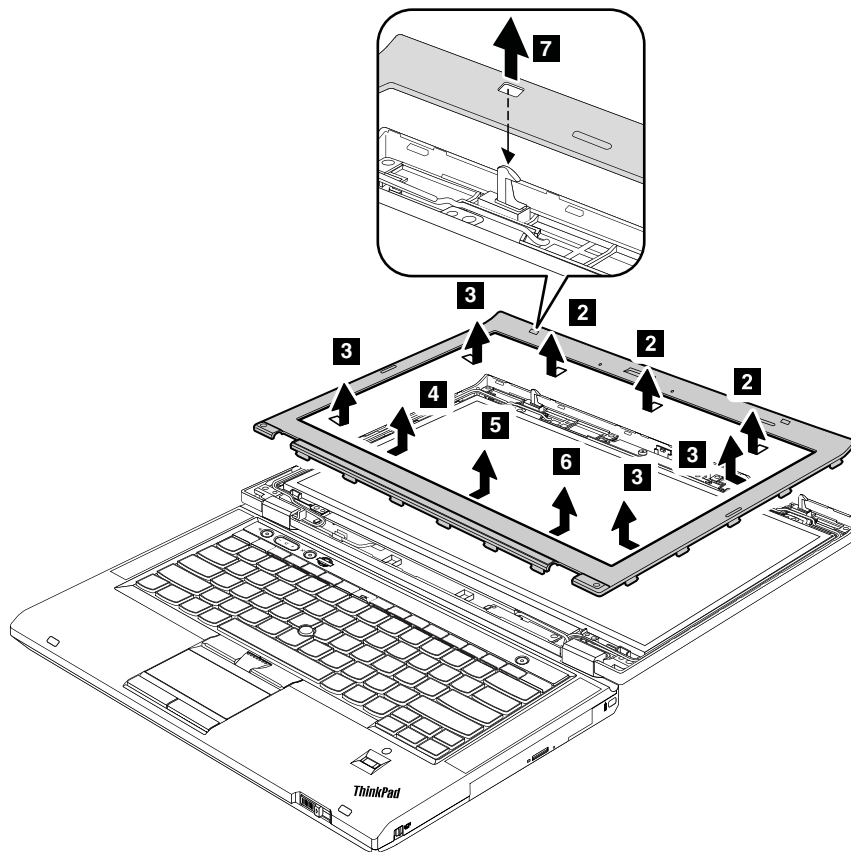

2020 LCD panel

For access, remove these FRUs in order:

- “1010 Battery pack” on page 60
- “2010 LCD bezel assembly” on page 95

The LCD panel and the peripheral parts used in this product are very sensitive. Improper handling of the LCD panel can cause damage to the parts, and might cause a system malfunction such as a missing dot, missing line, or pixel problems.

- Do not apply any kind of pressure to the LCD panel.
- When you lift the LCD panel, always hold the left and right edges of the panel with both of your hands. Do not hold the panel with one hand or hold the top and bottom edges of the panel.
- Do not touch or apply any kind of pressure to the print circuit board or sensitive parts **a** as shown in the following illustration.

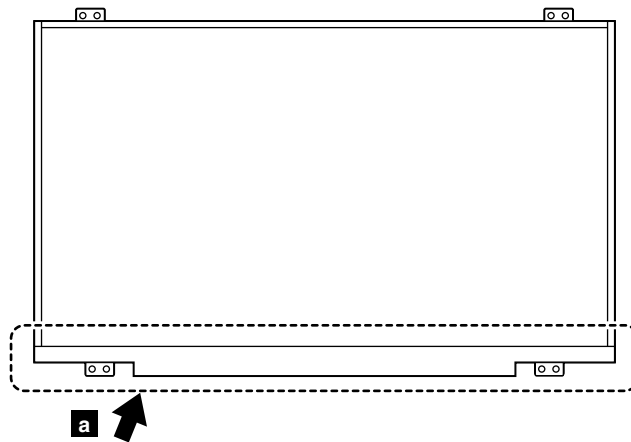

Removal steps of LCD panel

Attention: Unplug the LCD cable by holding the left and right edges of the connector with your fingers, and gently pull the connector towards you. Do not unplug the cable by pulling it. Applying tension to the cable could cause the cable to be damaged or a wire to be broken.

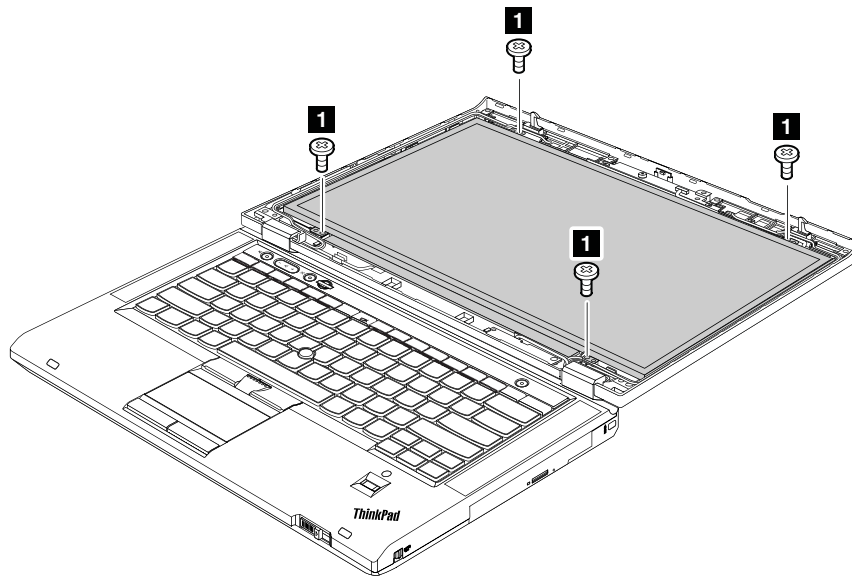

Step	Screw (quantity)	Color	Torque
1	M2 × 3 mm, small-head, nylon-coated (4)	Silver	0.181 Nm (1.85 kgf-cm)

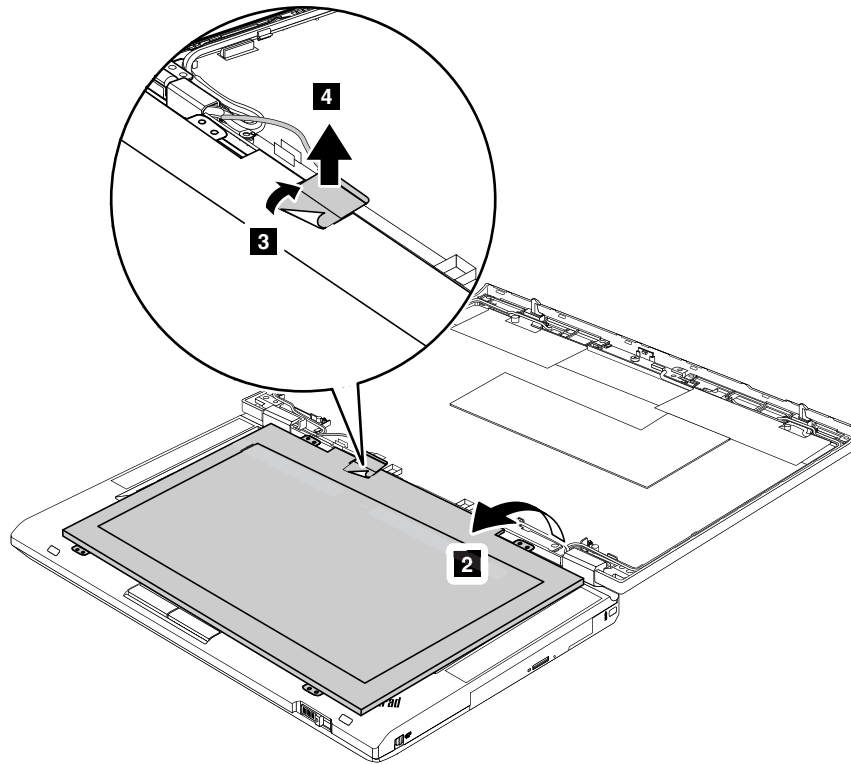

When installing:

When attaching the LCD panel to the cover, gently press the left and right edges covered with metal. Do not press the surface of the panel or apply any excessive force to the panel.

2030 Integrated camera, microphone, or hall sensor card

For access, remove these FRUs, in order:

- “1010 Battery pack” on page 60
- “2010 LCD bezel assembly” on page 95
- “2020 LCD panel” on page 96

The computer you are servicing might have an integrated camera, microphone, or hall sensor card.

Removal steps of integrated camera, microphone, or hall sensor card

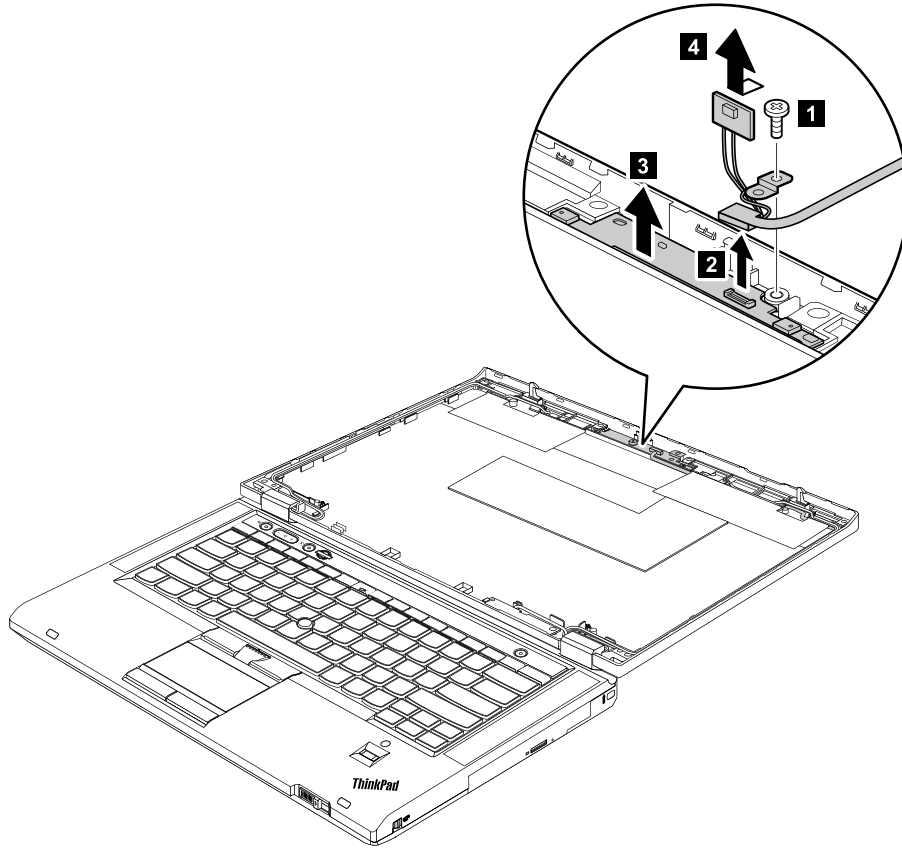

Step	Screw (quantity)	Color	Torque
1	M2 × 3 mm, small-head, nylon-coated (1)	Silver	0.181 Nm (1.85 kgf-cm)

When installing:

Make sure that the connector is attached firmly.

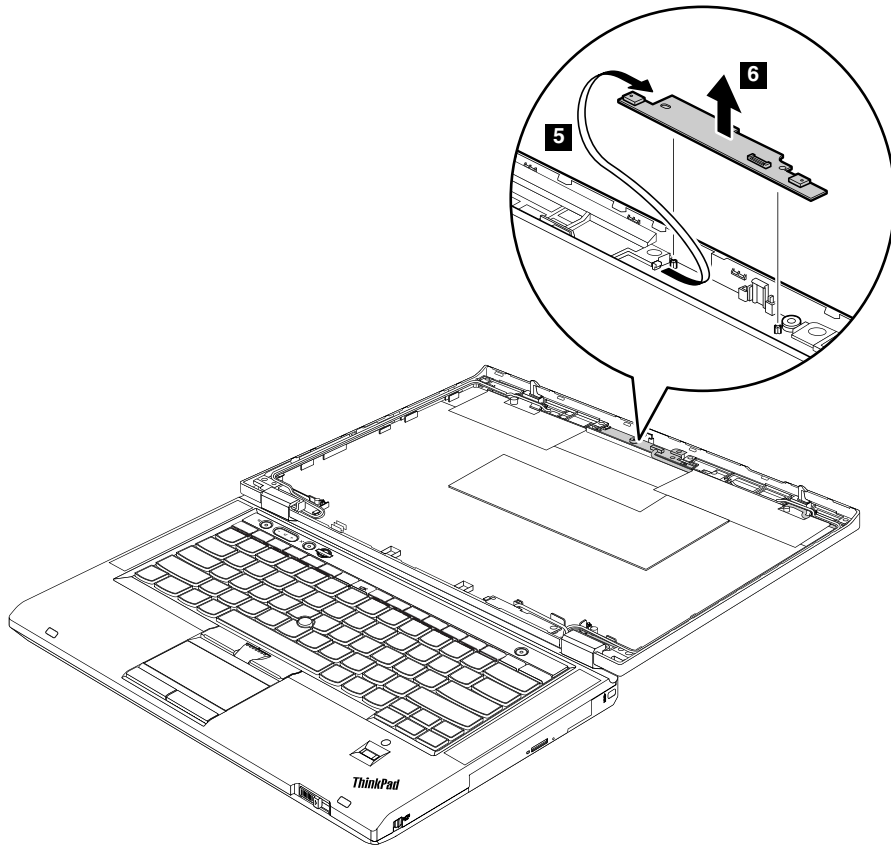

2040 LED sub card

For access, remove these FRUs in order:

- “1010 Battery pack” on page 60
- “2010 LCD bezel assembly” on page 95
- “2020 LCD panel” on page 96

Removal steps of LED sub card

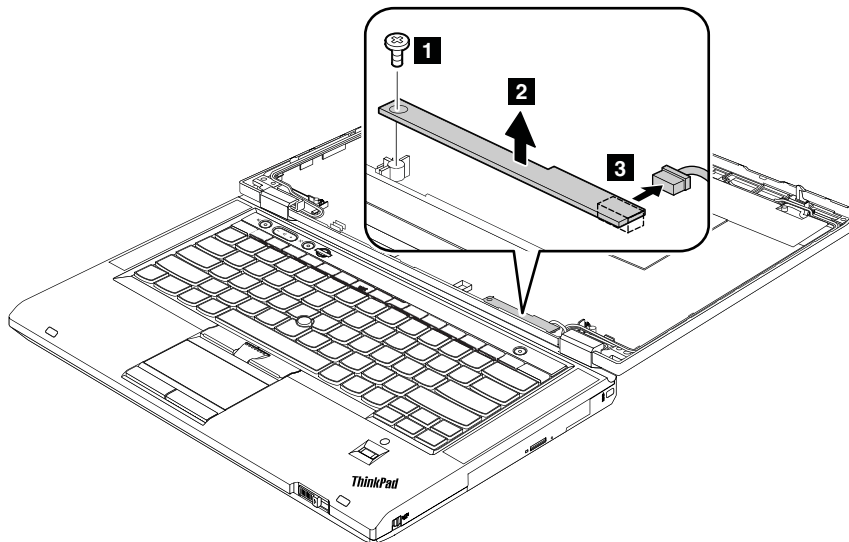

Step	Screw (quantity)	Color	Torque
1	M2 × 3 mm, small-head, nylon-coated (1)	Silver	0.181 Nm (1.85 kgf-cm)

When installing:

Make sure that the connector is attached firmly.

2050 LCD cable

For access, remove these FRUs in order:

- “1010 Battery pack” on page 60
- “1020 Serial Ultrabay Slim device or blank bezel” on page 61
- “1030 Solid-state drive or hard disk drive” on page 62
- “1040 Memory module” on page 64
- “1050 PCI Express Mini Card for wireless LAN” on page 65
- “1060 PCI Express Mini Card for wireless WAN or mSATA solid-state drive” on page 68
- “1070 4-in-1 media card reader or ExpressCard reader” on page 75
- “1080 Keyboard” on page 75
- “1100 Keyboard bezel assembly with fingerprint reader, smart card reader, and speaker assembly” on page 81
- “1110 LCD unit” on page 85
- “1120 DC-in sub card” on page 87
- “1140 Bluetooth wireless radio switch FPC” on page 89
- “1150 System board, thermal fan assembly, 34-mm ExpressCard reader, and base cover” on page 90
- “2010 LCD bezel assembly” on page 95
- “2020 LCD panel” on page 96
- “2030 Integrated camera, microphone, or hall sensor card” on page 98
- “2040 LED sub card” on page 100

Removal steps of LCD cable

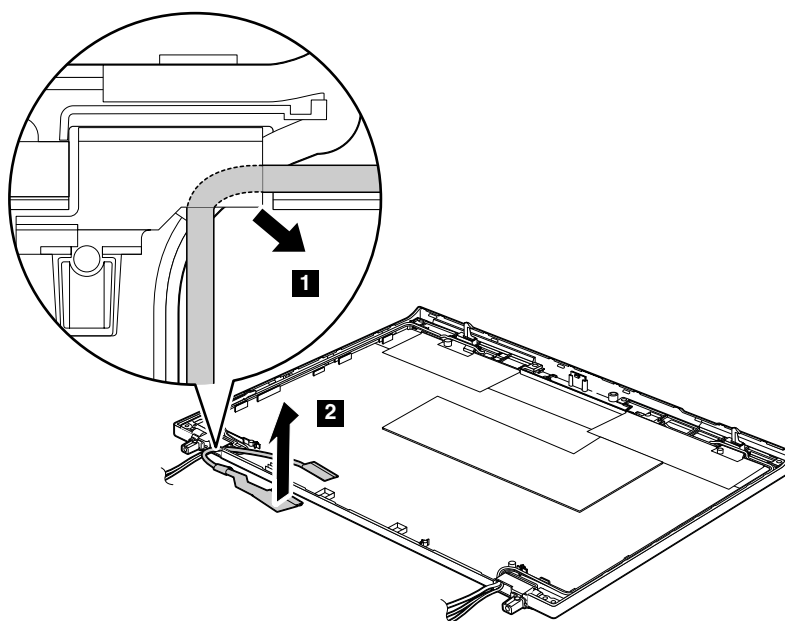

Cable routing:

When you install the LCD cable, route the cable as shown in the illustration above.

2060 Hinge kit

For access, remove these FRUs in order:

- “1010 Battery pack” on page 60
- “1020 Serial Ultrabay Slim device or blank bezel” on page 61
- “1030 Solid-state drive or hard disk drive” on page 62
- “1040 Memory module” on page 64
- “1050 PCI Express Mini Card for wireless LAN” on page 65
- “1060 PCI Express Mini Card for wireless WAN or mSATA solid-state drive” on page 68
- “1070 4-in-1 media card reader or ExpressCard reader” on page 75
- “1080 Keyboard” on page 75
- “1100 Keyboard bezel assembly with fingerprint reader, smart card reader, and speaker assembly” on page 81
- “1110 LCD unit” on page 85
- “1120 DC-in sub card” on page 87
- “1140 Bluetooth wireless radio switch FPC” on page 89
- “1150 System board, thermal fan assembly, 34-mm ExpressCard reader, and base cover” on page 90
- “2010 LCD bezel assembly” on page 95
- “2020 LCD panel” on page 96
- “2030 Integrated camera, microphone, or hall sensor card” on page 98
- “2040 LED sub card” on page 100
- “2050 LCD cable” on page 101

Removal steps of hinge kit

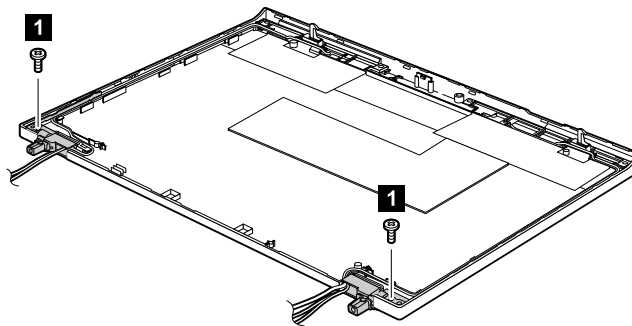

Step	Screw (quantity)	Color	Torque
1	M2 × 5 mm, bind-head, nylon-coated (2)	Black	0.181 Nm (1.85 kgf-cm)

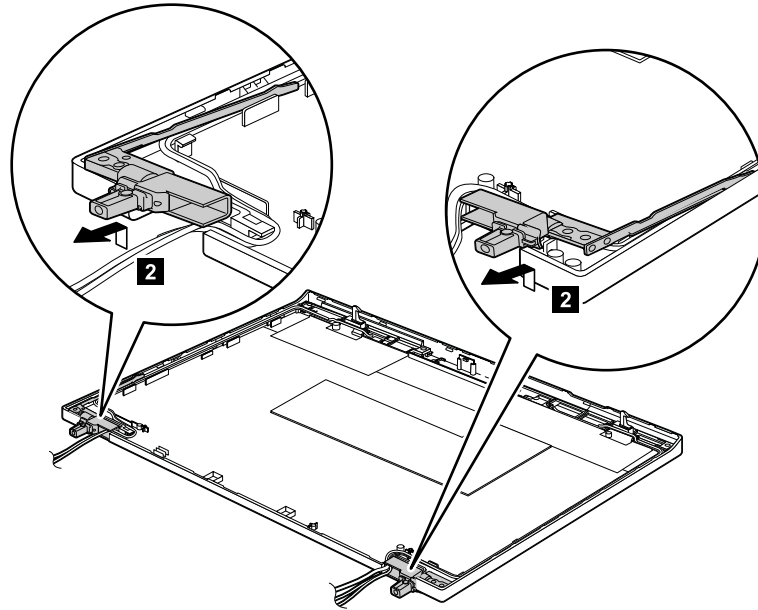

Cable routing:

When you install the hinge kit, route the cables as shown in the following illustration.

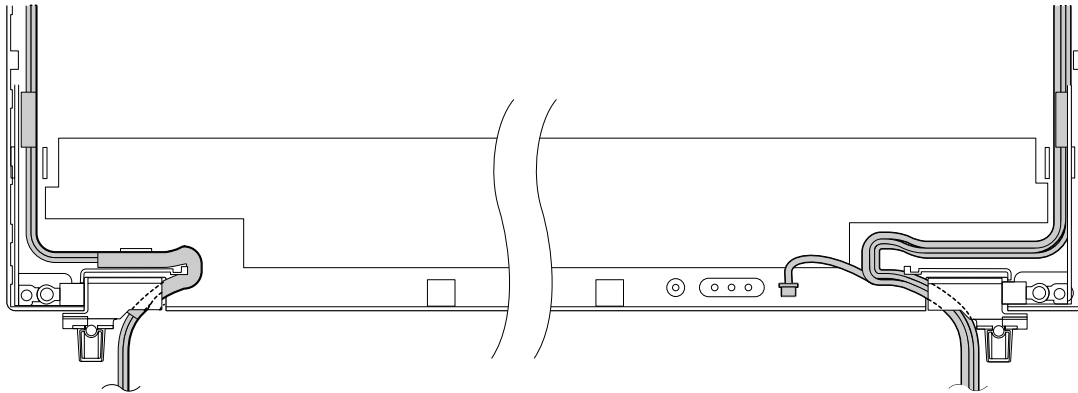

2070 LED cable

For access, remove these FRUs in order:

- “1010 Battery pack” on page 60
- “1020 Serial Ultrabay Slim device or blank bezel” on page 61
- “1030 Solid-state drive or hard disk drive” on page 62
- “1040 Memory module” on page 64
- “1050 PCI Express Mini Card for wireless LAN” on page 65
- “1060 PCI Express Mini Card for wireless WAN or mSATA solid-state drive” on page 68
- “1070 4-in-1 media card reader or ExpressCard reader” on page 75
- “1080 Keyboard” on page 75
- “1100 Keyboard bezel assembly with fingerprint reader, smart card reader, and speaker assembly” on page 81
- “1110 LCD unit” on page 85
- “1120 DC-in sub card” on page 87
- “1140 Bluetooth wireless radio switch FPC” on page 89

- “1150 System board, thermal fan assembly, 34-mm ExpressCard reader, and base cover” on page 90
- “2010 LCD bezel assembly” on page 95
- “2020 LCD panel” on page 96
- “2030 Integrated camera, microphone, or hall sensor card” on page 98
- “2040 LED sub card” on page 100
- “2050 LCD cable” on page 101
- “2060 Hinge kit” on page 102

Removal steps of LED cable

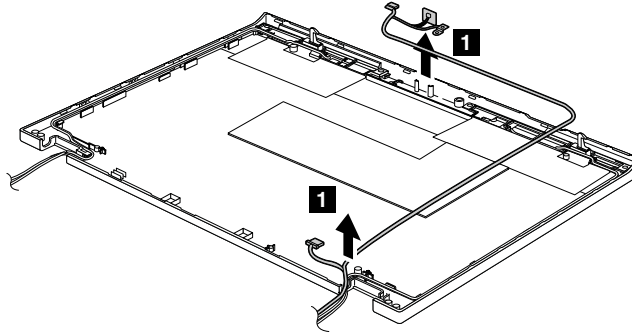

Cable routing:

When you install the LED cable, route the cable as shown in the following illustration.

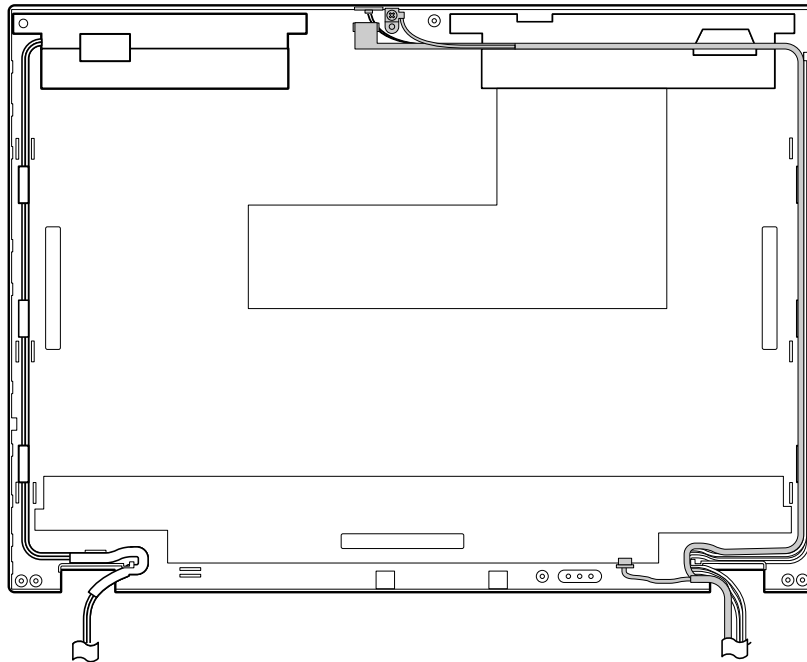

2080 Antenna kit and LCD rear cover assembly

For access, remove these FRUs in order:

- “1010 Battery pack” on page 60
- “1020 Serial Ultrabay Slim device or blank bezel” on page 61
- “1030 Solid-state drive or hard disk drive” on page 62
- “1040 Memory module” on page 64

- “1050 PCI Express Mini Card for wireless LAN” on page 65
- “1060 PCI Express Mini Card for wireless WAN or mSATA solid-state drive” on page 68
- “1070 4-in-1 media card reader or ExpressCard reader” on page 75
- “1080 Keyboard” on page 75
- “1100 Keyboard bezel assembly with fingerprint reader, smart card reader, and speaker assembly” on page 81
- “1110 LCD unit” on page 85
- “1120 DC-in sub card” on page 87
- “1140 Bluetooth wireless radio switch FPC” on page 89
- “1150 System board, thermal fan assembly, 34-mm ExpressCard reader, and base cover” on page 90
- “2010 LCD bezel assembly” on page 95
- “2020 LCD panel” on page 96
- “2030 Integrated camera, microphone, or hall sensor card” on page 98
- “2040 LED sub card” on page 100
- “2050 LCD cable” on page 101
- “2060 Hinge kit” on page 102
- “2070 LED cable” on page 103

Removal steps of antenna kit and LCD rear cover assembly

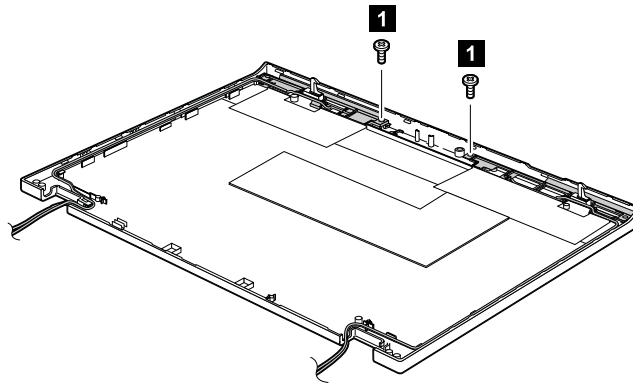

Step	Screw (quantity)	Color	Torque
1	M2 × 3 mm, flat-head, nylon-coated (2)	Silver	0.181 Nm (1.85 kgf-cm)

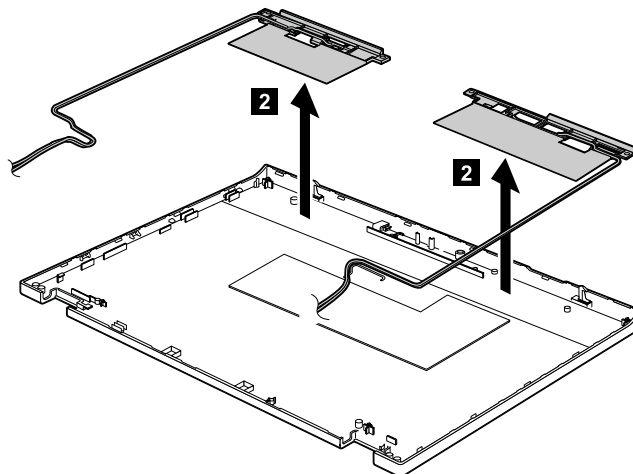

Cable routing:

When you install the antenna kit, route the cables as shown in the following illustration. As you route the cables, make sure that they are not subject to any tension. Tension could cause the cables to be damaged by the cable guides, or a wire to be broken.

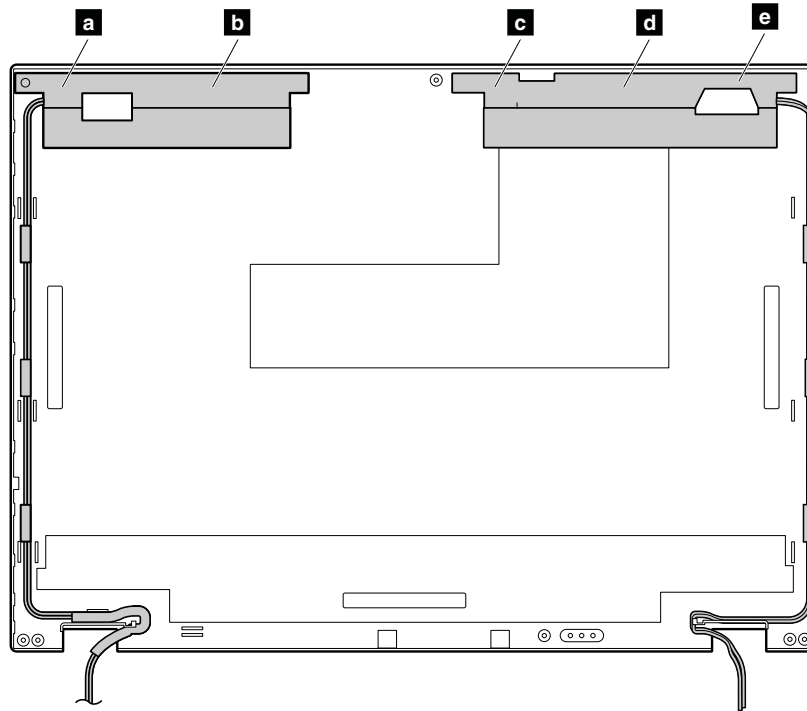

Type 1: Antenna location

- a** Wireless LAN and WiMAX combo antenna (Main)
- b** Wireless WAN antenna (Main)
- c** Wireless WAN antenna (Auxiliary)
- d** Wireless LAN antenna (Third)
- e** Wireless LAN and WiMAX combo antenna (Auxiliary)

Type 2: Antenna location

- a** Wireless LAN and WiMAX combo antenna (Main)
- b** Wireless WAN antenna (Main)
- c** Wireless LAN antenna (Third)
- d** Wireless LAN and WiMAX combo antenna (Auxiliary)
- e** Wireless WAN antenna (Auxiliary)

Appendix A. Notices

Lenovo may not offer the products, services, or features discussed in this document in all countries. Consult your local Lenovo representative for information on the products and services currently available in your area. Any reference to a Lenovo product, program, or service is not intended to state or imply that only that Lenovo product, program, or service may be used. Any functionally equivalent product, program, or service that does not infringe any Lenovo intellectual property right may be used instead. However, it is the user's responsibility to evaluate and verify the operation of any other product, program, or service.

Lenovo may have patents or pending patent applications covering subject matter described in this document. The furnishing of this document does not give you any license to these patents. You can send license inquiries, in writing, to:

*Lenovo (United States), Inc.
1009 Think Place - Building One
Morrisville, NC 27560
U.S.A.
Attention: Lenovo Director of Licensing*

LENOVO GROUP LTD. PROVIDES THIS PUBLICATION "AS IS" WITHOUT WARRANTY OF ANY KIND, EITHER EXPRESS OR IMPLIED, INCLUDING, BUT NOT LIMITED TO, THE IMPLIED WARRANTIES OF NON-INFRINGEMENT, MERCHANTABILITY OR FITNESS FOR A PARTICULAR PURPOSE. Some jurisdictions do not allow disclaimer of express or implied warranties in certain transactions, therefore, this statement may not apply to you.

This information could include technical inaccuracies or typographical errors. Changes are periodically made to the information herein; these changes will be incorporated in new editions of the publication. Lenovo may make improvements and/or changes in the product(s) and/or the program(s) described in this publication at any time without notice.

The products described in this document are not intended for use in implantation or other life support applications where malfunction may result in injury or death to persons. The information contained in this document does not affect or change Lenovo product specifications or warranties. Nothing in this document shall operate as an express or implied license or indemnity under the intellectual property rights of Lenovo or third parties. All information contained in this document was obtained in specific environments and is presented as an illustration. The result obtained in other operating environments may vary.

Lenovo may use or distribute any of the information you supply in any way it believes appropriate without incurring any obligation to you.

Any references in this publication to non-Lenovo Web sites are provided for convenience only and do not in any manner serve as an endorsement of those Web sites. The materials at those Web sites are not part of the materials for this Lenovo product, and use of those Web sites is at your own risk.

Any performance data contained herein was determined in a controlled environment. Therefore, the result obtained in other operating environments may vary significantly. Some measurements may have been made on development-level systems and there is no guarantee that these measurements will be the same on generally available systems. Furthermore, some measurements may have been estimated through extrapolation. Actual results may vary. Users of this document should verify the applicable data for their specific environment.

Electronic emissions notices

For electronic emission information on Class B digital devices, refer to the corresponding information in the *User Guide*.



Trademarks

The following terms are trademarks of Lenovo in the United States, other countries or both:

- Active Protection System
- Lenovo
- ThinkLight
- ThinkPad
- TrackPoint
- Ultrabay
- UltraNav

Microsoft, Windows, and Windows Server are trademarks of the Microsoft group of companies.

Intel is a trademark of Intel Corporation in the U.S. and/or other countries.

Other company, product, or service names may be the trademarks or service marks of others.

ThinkPad®

Part Number: 0B48538_01

Printed in China

(1P) P/N: 0B48538_01

