

lenovo

Hardware Maintenance Manual

Lenovo B590

Note: Before using this information and the product it supports, be sure to read the general information under Appendix A “Notices” on page 95.

Third Edition (April 2013)

© Copyright Lenovo 2012.

LIMITED AND RESTRICTED RIGHTS NOTICE: If data or software is delivered pursuant a General Services Administration “GSA” contract, use, reproduction, or disclosure is subject to restrictions set forth in Contract No. GS-35F-05925.

Contents

About this manual.	iii	Screw notices	41
Chapter 1. Safety information.	1	Chapter 7. Removing and replacing a FRU	43
General safety	1	General guidelines	43
Electrical safety	2	1010 Battery pack	44
Safety inspection guide	3	1020 Bottom slot cover	44
Handling devices that are sensitive to electrostatic discharge.	3	1030 Optical drive	45
Grounding requirements	4	1040 Memory modules	46
Safety notices (multilingual translations).	4	1050 Hard disk drive assembly	47
Laser compliance statement (multilingual translations).	19	1060 PCI Express Mini Card for wireless LAN	49
Chapter 2. Important service information	27	1070 mSATA solid state drive	51
Strategy for replacing FRUs	27	1080 Backup battery	52
Strategy for replacing a hard disk drive	28	1090 Keyboard	53
Important notice for replacing a system board	28	1100 Keyboard bezel	56
Important information about replacing RoHS compliant FRUs	28	1110 LED board	58
Chapter 3. General checkout	29	1120 Power board and touch pad bracket	59
What to do first	29	1130 Microphone assembly	60
Power system checkout	30	1140 I/O board	61
Checking the ac power adapter	30	1150 System board assembly and USB board	62
Checking operational charging	31	1160 DC-in connector.	65
Checking the battery pack	31	1170 Thermal module	66
Chapter 4. Related service information	33	1180 CPU	68
Recovering the computer settings	33	1190 LCD unit	69
Passwords	33	1210 Speaker assembly and base cover	71
Power-on password	34	2010 LCD front bezel	73
Supervisor password	34	2020 Camera	74
Power management	34	2030 LCD panel, LCD cable, and hinges	75
Screen blank mode	34	2040 Antenna assembly and LCD rear cover	77
Sleep mode	34	Chapter 8. Locations	79
Hibernation mode	35	Right-side view	79
Chapter 5. Lenovo B590.	37	Bottom view	80
Specifications	37	Chapter 9. Parts list	81
Status indicators	38	Overall	82
Fn key combinations	39	LCD FRUs	85
Chapter 6. FRU replacement notices	41	Keyboard	87
		Miscellaneous parts	89
		ac power adapters	90
		Power cords	91
		Appendix A. Notices.	95
		Electronic emissions notices	96
		Trademarks	96

About this manual

This manual provides service and reference information for the following Lenovo® products.

Machine	Machine type (MT)
Lenovo B590	3761, 6274, 20206, 20208

Use this manual to troubleshoot problems.

The manual is divided into the following sections:

- The common sections provide general information, guidelines, and safety information required for servicing computers.
- The product-specific section includes service, reference, and product-specific parts information.

Important:

- This manual is intended only for trained service technicians who are familiar with Lenovo products. Use this manual to troubleshoot problems effectively.
- Before servicing a Lenovo product, be sure to read all the information under Chapter 1 “Safety information” on page 1 and Chapter 2 “Important service information” on page 27.

Chapter 1. Safety information

This chapter presents following safety information that you need to be familiar with before you service a Lenovo Notebook.

- “General safety” on page 1
- “Electrical safety” on page 2
- “Safety inspection guide” on page 3
- “Handling devices that are sensitive to electrostatic discharge” on page 3
- “Grounding requirements” on page 4
- “Safety notices (multilingual translations)” on page 4
- “Laser compliance statement (multilingual translations)” on page 19

General safety

Follow these rules to ensure general safety:

- Observe good housekeeping in the area of the machines during and after maintenance.
- When lifting any heavy object:
 1. Make sure that you can stand safely without slipping.
 2. Distribute the weight of the object equally between your feet.
 3. Use a slow lifting force. Never move suddenly or twist when you attempt to lift.
 4. Lift by standing or by pushing up with your leg muscles; this action removes the strain from the muscles in your back. Do not attempt to lift any object that weighs more than 16 kg (35 lb) or that you think is too heavy for you.
- Do not perform any action that causes hazards to the customer, or that makes the equipment unsafe.
- Before you start the machine, make sure that other service technicians and the customer's personnel are not in a hazardous position.
- Place removed covers and other parts in a safe place, away from all personnel, while you are servicing the machine.
- Keep your toolcase away from walk areas so that other people will not trip over it.
- Do not wear loose clothing that can be trapped in the moving parts of a machine. Make sure that your sleeves are fastened or rolled up above your elbows. If your hair is long, fasten it.
- Insert the ends of your necktie or scarf inside clothing or fasten it with a nonconductive clip, about 8 centimeters (3 inches) from the end.
- Do not wear jewelry, chains, metal-frame eyeglasses, or metal fasteners for your clothing, because metal objects are good electrical conductors.
- Wear safety glasses when you are hammering, drilling, soldering, cutting wire, attaching springs, using solvents, or working in any other conditions that might be hazardous to your eyes.
- After service, reinstall all safety shields, guards, labels, and ground wires. Replace any safety device that is worn or defective.
- Reinstall all covers correctly before returning the machine to the customer.
- Fan louvers on the machine help to prevent overheating of internal components. Do not obstruct fan louvers or cover them with labels or stickers.

Electrical safety

Observe the following rules when working on electrical equipment.

Important:

Use only approved tools and test equipment. Some hand tools have handles covered with a soft material that does not insulate you when working with live electrical currents.

Many customers have, near their equipment, rubber floor mats that contain small conductive fibers to decrease electrostatic discharges. Do not use this type of mat to protect yourself from electrical shock.

- Find the room emergency power-off (EPO) switch, disconnecting switch, or electrical outlet. If an electrical accident occurs, you can then operate the switch or unplug the power cord quickly.
- Do not work alone under hazardous conditions or near equipment that has hazardous voltages.
- Disconnect all power before:
 - Performing a mechanical inspection
 - Working near power supplies
 - Removing or installing main units
- Before you start to work on the machine, unplug the power cord. If you cannot unplug it, ask the customer to power-off the wall box that supplies power to the machine, and to lock the wall box in the off position.
- If you need to work on a machine that has *exposed* electrical circuits, observe the following precautions:
 - Ensure that another person, familiar with the power-off controls, is near you.

Attention: Another person must be there to switch off the power, if necessary.

- Use only one hand when working with powered-on electrical equipment; keep the other hand in your pocket or behind your back.

Attention: An electrical shock can occur only when there is a complete circuit. By observing the above rule, you may prevent a current from passing through your body.

- When using testers, set the controls correctly and use the approved probe leads and accessories for that tester.
- Stand on suitable rubber mats (obtained locally, if necessary) to insulate you from grounds such as metal floor strips and machine frames.

Observe the special safety precautions when you work with very high voltages; Instructions for these precautions are in the safety sections of maintenance information. Use extreme care when measuring high voltages.

- Regularly inspect and maintain your electrical hand tools for safe operational condition.
- Do not use worn or broken tools and testers.
- *Never assume* that power has been disconnected from a circuit. First, *check* that it has been powered off.
- Always look carefully for possible hazards in your work area. Examples of these hazards are moist floors, nongrounded power extension cables, power surges, and missing safety grounds.
- Do not touch live electrical circuits with the reflective surface of a plastic dental mirror. The surface is conductive; such touching can cause personal injury and machine damage.
- Do not service the following parts *with the power on* when they are removed from their normal operating places in a machine:
 - Power supply units
 - Pumps
 - Blowers and fans
 - Motor generators
 - Similar units to listed above

This practice ensures correct grounding of the units.

- If an electrical accident occurs:

- Use caution; do not become a victim yourself.
- Switch off power.
- Send another person to get medical aid.

Safety inspection guide

The purpose of this inspection guide is to assist you in identifying potentially unsafe conditions. As each machine was designed and built, required safety items were installed to protect users and service technicians from injury. This guide addresses only those items. You should use good judgment to identify potential safety hazards due to attachment of non-Lenovo features or options not covered by this inspection guide.

If any unsafe conditions are present, you must determine how serious the apparent hazard could be and whether you can continue without first correcting the problem.

Consider these conditions and the safety hazards they present:

- Electrical hazards, especially primary power (primary voltage on the frame can cause serious or fatal electrical shock)
- Explosive hazards, such as a damaged CRT face or a bulging capacitor
- Mechanical hazards, such as loose or missing hardware

To determine whether there are any potentially unsafe conditions, use the following checklist at the beginning of every service task. Begin the checks with the power off, and the power cord disconnected.

Checklist:

1. Check exterior covers for damage (loose, broken, or sharp edges).
2. Power off the computer. Disconnect the power cord.
3. Check the power cord for:
 - a. A third-wire ground connector in good condition. Use a meter to measure third-wire ground continuity for 0.1 ohm or less between the external ground pin and the frame ground.
 - b. The power cord should be the type specified in the parts list.
 - c. Insulation must not be frayed or worn.
4. Check for cracked or bulging batteries.
5. Remove the cover.
6. Check for any obvious non-Lenovo alterations. Use good judgment as to the safety of any non-Lenovo alterations.
7. Check inside the unit for any obvious unsafe conditions, such as metal filings, contamination, water or other liquids, or signs of fire or smoke damage.
8. Check for worn, frayed, or pinched cables.
9. Check that the power-supply cover fasteners (screws or rivets) have not been removed or tampered with.

Handling devices that are sensitive to electrostatic discharge

Any computer part containing transistors or integrated circuits (ICs) should be considered sensitive to electrostatic discharge (ESD.) ESD damage can occur when there is a difference in charge between objects. Protect against ESD damage by equalizing the charge so that the machine, the part, the work mat, and the person handling the part are all at the same charge.

Notes:

1. Use product-specific ESD procedures when they exceed the requirements noted here.

2. Make sure that the ESD protective devices you use have been certified (ISO 9000) as fully effective.

When handling ESD-sensitive parts:

- Keep the parts in protective packages until they are inserted into the product.
- Avoid contact with other people.
- Wear a grounded wrist strap against your skin to eliminate static on your body.
- Prevent the part from touching your clothing. Most clothing is insulative and retains a charge even when you are wearing a wrist strap.
- Use a grounded work mat to provide a static-free work surface. The mat is especially useful when handling ESD-sensitive devices.
- Select a grounding system, such as those listed below, to provide protection that meets the specific service requirement.

Note: The use of a grounding system to guard against ESD damage is desirable but not necessary.

- Attach the ESD ground clip to any frame ground, ground braid, or green-wire ground.
- When working on a double-insulated or battery-operated system, use an ESD common ground or reference point. You can use coax or connector-outside shells on these systems.
- Use the round ground prong of the ac plug on ac-operated computers.

Grounding requirements

Electrical grounding of the computer is required for operator safety and correct system function. Proper grounding of the electrical outlet can be verified by a certified electrician.

Safety notices (multilingual translations)

The safety notices in this section are provided in the following languages:

- English
- Arabic
- Brazilian Portuguese
- French
- German
- Hebrew
- Japanese
- Korean
- Spanish
- Traditional Chinese



DANGER

Before the computer is powered on after FRU replacement, make sure that all screws, springs, and other small parts are in place and are not left loose inside the computer. Verify this by shaking the computer and listening for rattling sounds. Metallic parts or metal flakes can cause electrical short circuits.



DANGER

Some standby batteries contain a small amount of nickel and cadmium. Do not disassemble a standby battery, recharge it, throw it into fire or water, or short-circuit it. Dispose of the battery as required by local ordinances or regulations. Use only the battery in the appropriate parts listing. Use of an incorrect battery can result in ignition or explosion of the battery.



DANGER

The battery pack contains small amounts of nickel. Do not disassemble it, throw it into fire or water, or short-circuit it. Dispose of the battery pack as required by local ordinances or regulations. Use only the battery in the appropriate parts listing when replacing the battery pack. Use of an incorrect battery can result in ignition or explosion of the battery.



DANGER

The lithium battery can cause a fire, an explosion, or a severe burn. Do not recharge it, remove its polarized connector, disassemble it, heat it above 100°C (212°F), incinerate it, or expose its cell contents to water. Dispose of the battery as required by local ordinances or regulations. Use only the battery in the appropriate parts listing. Use of an incorrect battery can result in ignition or explosion of the battery.



DANGER

If the LCD breaks and the fluid from inside the LCD gets into your eyes or on your hands, immediately wash the affected areas with water for at least 15 minutes. Seek medical care if any symptoms from the fluid are present after washing.



DANGER

To avoid shock, do not remove the plastic cover that protects the lower part of the inverter card.



DANGER

Though the main batteries have low voltage, a short-circuited or grounded battery can produce enough current to burn personnel or combustible materials.



DANGER

Unless hot swap is allowed for the FRU being replaced, do as follows before removing it: power off the computer, unplug all power cords from electrical outlets, remove the battery pack, and disconnect any interconnecting cables.



قبل اعادة تشغيل الحاسب بعد الانتهاء من استبدال FRU، تأكد من أنه قد تم اعادة كل من المسامير و السوست وكل الأجزاء الصغيرة الأخرى في أماكنهم ولم يتم فقدهم داخل الحاسب. ويمكن التحقق من ذلك عن طريق هز الحاسب والاستماع لأي صوت صاخب يصدر منه. قد تؤدي الأجزاء أو الرقائق المعدنية الى حدوث دائرة قصر.



تحتوي بعض البطاريات الاحتياطية على كمية صغيرة من مادتي النيكل والكادميوم. لا تقم بفك أو اعادة شحن البطارية الاحتياطية ولا تقم أيضا بالقائها في النار أو الماء ولا تتسبب في احداث دائرة قصر بها. قم بالتخلص من البطارية كما هو موضح في القوانين المحلية. استخدم نوع البطارية المحدد والذي يوصى باستخدامه. حيث أنه قد يؤدي استخدام نوع بطارية غير صحيح الى اشتعالها أو انفجارها.



تحتوي حزمة البطارية على كمية صغيرة من مادة النيكل. لا تقم بفكها أو القاءها في النار أو الماء ولا تتسبب في احداث دائرة قصر بها. تخلص من حزمة البطارية وفقا لما هو موضح في القوانين المحلية. قم، عند استبدال حزمة البطارية، باستخدام الأنواع المحددة فقط والتي يوصى باستخدامها. حيث أنه قد يؤدي استخدام نوع بطارية غير صحيح الى اشتعالها أو انفجارها.



قد تتسبب بطارية الليثيوم في حدوث حريق أو انفجار أو حدوث حروق شديدة. لا تقم بإعادة شحن البطارية أو إزالة موصل الاستقطاب الخاص بها ولا تحاول أيضا فكها أو تسخينها لأكثر من ١٠٠ درجة مئوية (٢١٢١ فهرنهايت) أو حرقها أو تعريض محتويات الخانة الخاصة بها للماء. قم بالتخلص من البطارية وفقا لما هو موضح في القوانين المحلية. استخدم نوع البطارية المحدد والذي يوصى باستخدامه. حيث أنه قد يؤدي استخدام نوع بطارية غير صحيح الى اشتعالها أو انفجارها.



خطر

إذا ما انكسرت شاشة LCD ولامس السائل الداخلي عينيك أو يديك، قم في الحال بغسلهما بالماء لمدة لا تقل عن ١٥ دقيقة. إذا ما وجدت أي أعراض بعد الغسل اطلب عندئذ المساعدة الطبية.



خطر

لتجنب التعرض لأي صدمات، لا تقم بإزالة الغطاء البلاستيكي الذي يحمي الجزء الأسفل من بطاقة العاكس.



خطر

على الرغم من أن البطاريات الرئيسية يكون لها جهد منخفض، إلا أنه قد تقوم البطاريات التي حدث قصور بها أو التي تم توصيلها أرضيا بإصدار تيار يكفي لحدوث حروق للأفراد أو تعرض المواد القابلة للاشتعال للحريق.



خطر

ما لم يتم السماح بالتبديل الفوري لأي FRU الجاري استبداله بدون ضرورة اغلاق النظام، قم بتنفيذ ما يلي قبل ازالته: قم بإيقاف تشغيل الحاسب ونزع كل أسلاك الطاقة من المخارج الكهربائية وقم أيضا بإزالة حزمة البطارية ثم قم بفصل أي كابلات متصلة.



PERIGO

Antes de ligar o computador após a substituição da FRU, certifique-se de que todos os parafusos, molas e outras peças pequenas estejam no lugar e não estejam soltos dentro do computador. Verifique isso sacudindo o computador e procurando ouvir sons de peças soltas. Peças metálicas ou lascas de metal podem causar curto-circuito.



PERIGO

Algumas baterias reserva contêm uma pequena quantidade de níquel e cádmio. Não desmonte uma bateria reserva, recarregue-a, jogue-a no fogo ou na água, ou deixe-a entrar em curto-circuito. Descarte a bateria conforme requerido pelas leis ou regulamentos locais. Use somente a bateria nas partes listadas apropriadas. O uso de uma bateria incorreta pode resultar em combustão ou explosão da bateria.



PERIGO

O pacote da bateria contém uma pequena quantidade de níquel. Não o desmonte, jogue-o no fogo ou na água, ou deixe-o entrar em curto-circuito. Descarte o pacote da bateria conforme requerido pelas leis ou regulamentos locais. Use somente a bateria nas partes listadas apropriadas ao substituir o pacote da bateria. O uso de uma bateria incorreta pode resultar em combustão ou explosão da bateria.



PERIGO

A bateria de lítio pode causar incêndio, explosão ou graves queimaduras. Não a recarregue, remova seu conector polarizado, desmonte-a, aqueça-a acima de 100°C (212°F), incinere-a, ou exponha o conteúdo de sua célula à água. Descarte a bateria conforme requerido pelas leis ou regulamentos locais. Use somente a bateria nas partes listadas apropriadas. O uso de uma bateria incorreta pode resultar em combustão ou explosão da bateria.



PERIGO

Se o LCD quebrar e o fluido de dentro dele entrar em contato com seus olhos ou com suas mãos, lave as áreas afetadas imediatamente com água durante pelo menos 15 minutos. Procure cuidados médicos se algum sintoma causado pelo fluido surgir após a lavagem.



PERIGO

Para evitar choque elétrico, não remova a capa plástica que protege a parte inferior da placa inversora.



PERIGO

Embora as principais baterias possuam baixa voltagem, uma bateria em curto-circuito ou aterrada pode produzir corrente o bastante para queimar materiais de pessoal ou inflamáveis.



PERIGO

A menos que uma hot swap seja permitida para a FRU que está sendo substituída, faça o seguinte antes de removê-la: desligue o computador, desconecte todos os cabos de energia das tomadas, remova o pacote de baterias e desconecte quaisquer cabos de interconexão.



DANGER

Avant de remettre l'ordinateur sous tension après remplacement d'une unité en clientèle, vérifiez que tous les ressorts, vis et autres pièces sont bien en place et bien fixées. Pour ce faire, secouez l'unité et assurez-vous qu'aucun bruit suspect ne se produit. Des pièces métalliques ou des copeaux de métal pourraient causer un court-circuit.



DANGER

Certaines batteries de secours contiennent du nickel et du cadmium. Ne les démontez pas, ne les rechargez pas, ne les exposez ni au feu ni à l'eau. Ne les mettez pas en court-circuit. Pour les mettre au rebut, conformez-vous à la réglementation en vigueur. Lorsque vous remplacez la pile de sauvegarde ou celle de l'horloge temps réel, veillez à n'utiliser que les modèles cités dans la liste de pièces détachées adéquate. Une batterie ou une pile inappropriée risque de prendre feu ou d'exploser.



DANGER

La batterie contient du nickel. Ne la démontez pas, ne l'exposez ni au feu ni à l'eau. Ne la mettez pas en court-circuit. Pour la mettre au rebut, conformez-vous à la réglementation en vigueur. Lorsque vous remplacez la batterie, veillez à n'utiliser que les modèles cités dans la liste de pièces détachées adéquate. En effet, une batterie inappropriée risque de prendre feu ou d'exploser.



DANGER

La pile de sauvegarde contient du lithium. Elle présente des risques d'incendie, d'explosion ou de brûlures graves. Ne la rechargez pas, ne retirez pas son connecteur polarisé et ne la démontez pas. Ne l'exposez pas à une température supérieure à 100°C, ne la faites pas brûler et n'en exposez pas le contenu à l'eau. Mettez la pile au rebut conformément à la réglementation en vigueur. Une pile inappropriée risque de prendre feu ou d'exploser.



DANGER

Si le panneau d'affichage à cristaux liquides se brise et que vous recevez dans les yeux ou sur les mains une partie du fluide, rincez-les abondamment pendant au moins quinze minutes. Consultez un médecin si des symptômes persistent après le lavage.



DANGER

Afin d'éviter tout risque de choc électrique, ne retirez pas le cache en plastique protégeant la partie inférieure de la carte d'alimentation.



DANGER

Bien que le voltage des batteries principales soit peu élevé, le court-circuit ou la mise à la masse d'une batterie peut produire suffisamment de courant pour brûler des matériaux combustibles ou causer des brûlures corporelles graves.



DANGER

Si le remplacement à chaud n'est pas autorisé pour l'unité remplaçable sur site que vous remplacez, procédez comme suit avant de retirer l'unité : mettez l'ordinateur hors tension, débranchez tous les cordons d'alimentation des prises de courant, retirez le bloc de batterie et déconnectez tous les câbles d'interconnexion.



VORSICHT

Bevor nach einem FRU-Austausch der Computer wieder angeschlossen wird, muß sichergestellt werden, daß keine Schrauben, Federn oder andere Kleinteile fehlen oder im Gehäuse vergessen wurden. Der Computer muß geschüttelt und auf Klappergeräusche geprüft werden. Metallteile oder-splitter können Kurzschlüsse erzeugen.



VORSICHT

Die Bereitschaftsbatterie, die sich unter dem Diskettenlaufwerk befindet, kann geringe Mengen Nickel und Cadmium enthalten. Sie darf nur durch die Verkaufsstelle oder den IBM Kundendienst ausgetauscht werden. Sie darf nicht zerlegt, wiederaufgeladen, kurzgeschlossen, oder Feuer oder Wasser ausgesetzt werden. Die Batterie kann schwere Verbrennungen oder Verätzungen verursachen. Bei der Entsorgung die örtlichen Bestimmungen für Sondermüll beachten. Beim Ersetzen der Bereitschafts-oder Systembatterie nur Batterien des Typs verwenden, der in der Ersatzteilliste aufgeführt ist. Der Einsatz falscher Batterien kann zu Entzündung oder Explosion führen.



VORSICHT

Akkus enthalten geringe Mengen von Nickel. Sie dürfen nicht zerlegt, wiederaufgeladen, kurzgeschlossen, oder Feuer oder Wasser ausgesetzt werden. Bei der Entsorgung die örtlichen Bestimmungen für Sondermüll beachten. Beim Ersetzen der Batterie nur Batterien des Typs verwenden, der in der Ersatzteilliste aufgeführt ist. Der Einsatz falscher Batterien kann zu Entzündung oder Explosion führen.



VORSICHT

Die Systembatterie ist eine Lithiumbatterie. Sie kann sich entzünden, explodieren oder schwere Verbrennungen hervorrufen. Batterien dieses Typs dürfen nicht aufgeladen, zerlegt, über 100°C erhitzt oder verbrannt werden. Auch darf ihr Inhalt nicht mit Wasser in Verbindung gebracht oder der zur richtigen Polung angebrachte Verbindungsstecker entfernt werden. Bei der Entsorgung die örtlichen Bestimmungen für Sondermüll beachten. Beim Ersetzen der Batterie nur Batterien des Typs verwenden, der in der Ersatzteilliste aufgeführt ist. Der Einsatz falscher Batterien kann zu Entzündung oder Explosion führen.



VORSICHT

Die Leuchtstoffröhre im LCD-Bildschirm enthält Quecksilber. Bei der Entsorgung die örtlichen Bestimmungen für Sondermüll beachten. Der LCD-Bildschirm besteht aus Glas und kann zerbrechen, wenn er unsachgemäß behandelt wird oder der Computer auf den Boden fällt. Wenn der Bildschirm beschädigt ist und die darin befindliche Flüssigkeit in Kontakt mit Haut und Augen gerät, sollten die betroffenen Stellen mindestens 15 Minuten mit Wasser abgespült und bei Beschwerden anschließend ein Arzt aufgesucht werden.



VORSICHT

Aus Sicherheitsgründen die Kunststoffabdeckung, die den unteren Teil der Spannungswandlerplatine umgibt, nicht entfernen.



VORSICHT

Obwohl Hauptbatterien eine niedrige Spannung haben, können sie doch bei Kurzschluß oder Erdung genug Strom abgeben, um brennbare Materialien zu entzünden oder Verletzungen bei Personen hervorzurufen.



VORSICHT

Wenn ein Austausch der FRU bei laufendem Betrieb nicht erlaubt ist, gehen Sie beim Austausch der FRU wie folgt vor: Schalten Sie den Computer aus, ziehen Sie alle Netzkabel von den Netzsteckdosen ab, entfernen Sie den Akku und ziehen Sie alle miteinander verbundenen Kabel ab.



סכנה

לפני הפעלת המחשב לאחר החלפת FRU יש לוודא שכל הברגים, הקפיצים, וחלקים קטנים אחרים נמצאים במקומם ואינם חופשיים לזוז בתוך המחשב. כדי לוודא זאת, יש לטלטל את המחשב ולהקשיב לגילוי קולות שקשוק. חלקי או שבבי מתכת עלולים לגרום לקצרים חשמליים.



סכנה

סוללות המתנה מסוימות מכילות כמות קטנה של ניקל וקדמיום. אין לפרק סוללת המתנה, לטעון אותה מחדש, להשליך אותה לאש או למים או לקצר אותה. יש לסלק את הסוללה כנדרש על ידי התקנות והחוקים המקומיים. יש להשתמש רק בסוללה המופיעה ברשימת החלקים המתאימה. שימוש בסוללה לא מתאימה עלול לגרום להצתה או התפוצצות של הסוללה.



סכנה

מארז הסוללה מכיל כמות קטנה של ניקל וקדמיום. אין לפרק את מארז הסוללה, להשליך אותו לאש או למים או לקצר אותו. יש לסלק את מארז הסוללה כנדרש על ידי התקנות והחוקים המקומיים. יש להשתמש רק בסוללה המופיעה ברשימת החלקים המתאימה בזמן החלפת מארז הסוללה. שימוש בסוללה לא מתאימה עלול לגרום להצתה או התפוצצות של הסוללה.



סכנה

סוללת הליתיום עלולה לגרום לשריפה, להתפוצצות או לכוויות קשות. אין לטעון אותה מחדש, לסלק את המחבר המקוטב שלה, לפרק אותה או לחמם אותה לטמפרטורה העולה על 100 מעלות צלזיוס. אין לשרוף את הסוללה ואין לחשוף את תוכן התא למים. יש לסלק את הסוללה כנדרש בתקנות ובחוקים המקומיים. יש להשתמש רק בסוללה המופיעה ברשימת החלקים המתאימים. שימוש בסוללה אחרת עלול לגרום לסכנת שריפה או התפוצצות.



סכנה

אם מסך הגביש הנוזלי (LCD) נשבר והנוזל מתוך המסך בא במגע עם עיניכם או ידיכם, שטפו את האזורים הנגועים מיד במים במשך 15 דקות לפחות. פנו לקבלת עזרה רפואית אם תסמינים הנובעים מהמגע עם הנוזל נמשכים לאחר השטיפה.



סכנה

כדי למנוע התחשמלות, אין להסיר את מכסה הפלסטיק המגן על חלקו התחתון של הכרטיס ההפוך.



סכנה

אף שהסוללות הראשיות הן בעלות מתח נמוך, סוללה מקוצרת או מוארכת עלולה להפיק זרם מספיק לגרימת כוויות או להצתת חומרים דליקים.



סכנה

אלא אם כן מותרת 'החלפה חמה' של ה-FRU המוחלף, פעלו כדלהלן לפני הסרתו: כבו את המחשב, נתקו את כל כבלי החשמל מהשקעים, הוציאו את מארז הסוללות ונתקו את כל הכבלים המחוברים.



危険

FRUの交換後、コンピュータの電源を入れる前に、ねじ、バネ、その他の小さな部品がすべて正しい位置にあり、またコンピュータの内部で緩んでいないことを確認してください。
これを確認するには、コンピュータを振って、カチャカチャと音がしないか確かめます。金属部品や金属破片はショートの原因になることがあります。



危険

予備バッテリーの中には少量のニッケルとカドミウムが含まれているものがあります。したがって、予備バッテリーの分解、再充電、火または水の中への投棄、またはショートさせることは決して行わないでください。バッテリーを廃棄する場合は地方自治体の条例に従ってください。適切なパーツ・リストにあるバッテリーだけを使用してください。誤ったバッテリーを使用すると、バッテリーが発火したり、爆発したりすることがあります。



バッテリー・パックには少量のニッケルが含まれています。バッテリー・パックを分解したり、火または水の中に投げ込んだり、ショートさせないでください。バッテリー・パックの廃棄にあたっては、地方自治体の条例または規則に従ってください。バッテリー・パックを交換するときは、適切なパーツ・リストにあるバッテリーだけを使用してください。誤ったバッテリーを使用すると、バッテリーが発火したり、爆発したりすることがあります。



リチウム・バッテリーは、火災、爆発、または重症のやけどを引き起こすことがあります。バックアップ・バッテリーの充電、その極性コネクタの取り外し、バッテリー本体の分解、100 °C (212 °F) 以上への加熱、焼却、電池の中身を水に浸すことはしないでください。バッテリーを廃棄する場合は地方自治体の条例に従ってください。適切なパーツ・リストにあるバッテリーだけを使用してください。誤ったバッテリーを使用すると、バッテリーが発火したり、爆発したりすることがあります。



LCD が破損し、LCD 中の液体が目に入ったり、手に触れたりした場合は、液体が触れた部分を少なくとも 15 分間洗い流してください。洗い流した後に、液体によって何らかの症状が現れた場合は、医師の治療を受けてください。



感電を防ぐため、インバーター・カードの下部を保護しているプラスチック・カバーを外さないでください。



メイン・バッテリーの電圧は低くても、ショートしたり、接地したバッテリーが、作業者にやけどを負わせたり、可燃物を燃やすだけの電流を発生させる場合があります。



危険

交換しようとしている FRU がホット・スワップに対応していない場合、それを取り外す前に、コンピューターの電源をオフにし、すべての電源コードをコンセントから抜き、バッテリー・パックを取り外して、相互接続しているケーブルをすべて切り離してください。



위험

FRU를 교체하고 나서 컴퓨터 전원을 켜기 전에 모든 나사, 스프링 및 기타 작은 부품들이 올바른 위치에 있는지, 컴퓨터 내부에 단단하게 연결되어 있는지 확인하십시오. 컴퓨터를 흔들어 달각거리는 소리가 나지 않는지 확인하십시오. 금속 부품 또는 금속 조각은 누전을 일으킬 수 있습니다.



위험

일부 보조 배터리에는 소량의 니켈 및 카드뮴이 포함되어 있습니다. 보조 배터리를 분해하거나, 다시 충전하거나, 불 또는 물에 던지거나, 단락시키지 마십시오. 배터리 팩을 폐기할 때에는 해당 지역의 법률 규정을 따르십시오. 배터리 팩을 교체할 때에는 올바른 배터리만 사용하십시오. 올바르지 않은 배터리를 사용하면 배터리가 발화되거나 폭발할 수 있습니다.



위험

배터리 팩에는 소량의 니켈이 포함되어 있습니다. 배터리 팩을 분해하거나, 불 또는 물에 던지거나, 단락시키지 마십시오. 배터리 팩을 폐기할 때에는 해당 지역의 법률 규정을 따르십시오. 배터리 팩을 교체할 때에는 올바른 배터리만 사용하십시오. 올바르지 않은 배터리를 사용하면 배터리가 발화되거나 폭발할 수 있습니다.



위험

리튬 배터리는 화재, 폭발 또는 심각한 화상을 일으킬 수 있습니다. 리튬 배터리를 다시 충전하거나, 극성 커넥터를 제거하거나, 분해하거나, 100C(212F) 이상으로 가열하거나, 소각하거나, 전지 내용물을 물에 노출시키지 마십시오. 배터리를 폐기할 때에는 해당 지역을 법률 규정을 따르십시오. 올바른 배터리만 사용하십시오. 올바르지 않은 배터리를 사용하면 배터리가 발화되거나 폭발할 수 있습니다.



위험

LCD가 파손되어 LCD 내부의 액체가 눈에 들어가거나 손에 묻으면 즉시 깨끗한 물로 15분 이상 닦아 내십시오. 씻은 후에 조금이라도 이상을 느낀다면 즉시 병원에 가서 의사의 진찰을 받아야 합니다.



위험

전기적 위험을 방지하려면 인버터 카드의 아래 부분을 보호하는 플라스틱 덮개를 제거하지 마십시오.



위험

기본 배터리의 전압은 낮지만, 단락되거나 접지된 배터리는 화상을 입히기에 충분한 전류와 가연성 물질을 발생시킬 수 있습니다.



위험

FRU 교체 시 Hot Swap이 지원되지 않는 경우, FRU를 제거하기 전에 컴퓨터의 전원을 끄고, 전기 콘센트에서 전원 코드를 분리하고, 배터리를 제거한 후, 연결된 모든 케이블을 분리하십시오.



PELIGRO

Antes de encender el sistema después de sustituir una FRU, compruebe que todos los tornillos, muelles y demás piezas pequeñas se encuentran en su sitio y no se encuentran sueltas dentro del sistema. Compruébelo agitando el sistema y escuchando los posibles ruidos que provocarían. Las piezas metálicas pueden causar cortocircuitos eléctricos.



PELIGRO

Algunas baterías de reserva contienen una pequeña cantidad de níquel y cadmio. No las desmonte, ni recargue, ni las eche al fuego o al agua ni las cortocircuite. Deséchelas tal como dispone la normativa local. Utilice sólo baterías que se encuentren en la lista de piezas. La utilización de una batería no apropiada puede provocar la ignición o explosión de la misma.



PELIGRO

Las baterías contienen pequeñas cantidades de níquel. No las desmonte, ni recargue, ni las eche al fuego o al agua ni las cortocircuite. Deséchelas tal como dispone la normativa local. Utilice sólo baterías que se encuentren en la lista de piezas al sustituir la batería. La utilización de una batería no apropiada puede provocar la ignición o explosión de la misma.

 PELIGRO

La batería de repuesto es una batería de litio y puede provocar incendios, explosiones o quemaduras graves. No la recargue, ni quite el conector polarizado, ni la desmonte, ni caliente por encima de los 100°C (212°F), ni la incinere ni exponga el contenido de sus celdas al agua. Deséchela tal como dispone la normativa local.

 PELIGRO

Si la LCD se rompe y el fluido de su interior entra en contacto con sus ojos o sus manos, lave inmediatamente las áreas afectadas con agua durante 15 minutos como mínimo. Obtenga atención medica si se presenta algún síntoma del fluido despues de lavarse.

 PELIGRO

Para evitar descargas, no quite la cubierta de plástico que rodea la parte baja de la tarjeta invertida.

 PELIGRO

Aunque las baterías principales tienen un voltaje bajo, una batería cortocircuitada o con contacto a tierra puede producir la corriente suficiente como para quemar material combustible o provocar quemaduras en el personal.

 PELIGRO

Salvo que se permita el intercambio en caliente para la unidad sustituible localmente, realice lo siguiente antes de extraerla: apague el sistema, desconecte todos los cables de alimentación de las tomas de alimentación eléctrica, extraiga la batería y desconecte los cables de interconexión.

 危險

完成 FRU 更換之後，在開啟電腦的電源之前，請確定所有螺絲、彈簧及其他小零件都已歸位，沒有遺留在電腦內部。
若要確認這一點，請搖晃電腦，聽聽看是否有卡嗒的聲響。
金屬零件或儀錶的火花會造成電線短路。

 危險

部分備用電池含有微量的鎳和鎘。請勿拆開備用電池、再充電、丟入火或水中，或使其形成短路。請按照當地法令或規定來棄置電池。

僅限使用零件清單中的電池。使用不適當的電池會導致電池起火或爆炸。



電池套件含有微量的鎳。請勿拆開電池套件、丟入火或水中，或使其形成短路。請按照當地法令或規定來棄置電池套件。

更換電池套件時，僅限使用零件清單中的電池。使用不適當的電池會導致電池起火或爆炸。



鋰電池會導致起火、爆炸或嚴重燒傷。請勿再充電、拔除其電極接頭、拆開、加熱超過 **100°C (212°F)**、焚燒，或讓電池組成物浸到水。請按照當地法令或規定來棄置電池。

僅限使用零件清單中的電池。使用不適當的電池會導致電池起火或爆炸。



如果 LCD 破裂導致 LCD 流出的液體沾到您的眼睛或手，請立即以清水沖洗沾染部位至少 15 分鐘。如果在清洗後出現該液體所造成的任何症狀，請就醫治療。



為避免電擊，請勿拆下轉換卡下面的塑膠護蓋。



雖然主電池的電壓很低，但短路或接地電池所產生的電流，仍足以使人燒傷或使可燃物質起火。



除非 FRU 允許以熱抽換來替換，否則請依下列方式將其移除：將電腦關機，拔除插座上所有電源線，移除電池包，並拔開任何交互連接的線材。

Laser compliance statement (multilingual translations)

The laser compliance statements in this section are provided in the following languages:

- English
- Arabic
- Brazilian Portuguese
- French
- German
- Hebrew
- Japanese
- Korean
- Spanish
- Traditional Chinese



CAUTION:

When laser products (such as CD-ROMs, DVD drives, fiber optic devices, or transmitters) are installed, note the following:

- Do not remove the covers. Removing the covers of the laser product could result in exposure to hazardous laser radiation. There are no serviceable parts inside the device.
- Use of controls or adjustments or performance of procedures other than those specified herein might result in hazardous radiation exposure.



DANGER

Some laser products contain an embedded Class 3A or Class 3B laser diode. Note the following.

Laser radiation when open. Do not stare into the beam, do not view directly with optical instruments, and avoid direct exposure to the beam.



تحذير:

عند تثبيت منتجات الليزر (مثل أقراص CD-ROM أو محركات تشغيل أقراص DVD أو أجهزة الألياف البصرية أو النواقل)، لاحظ ما يلي:

- لا تقم بنزع الغطاء. قد ينتج عن نزع غطاء منتج ليزر التعرض لأشعة ليزر في منتهى الخطورة. لا توجد أجزاء يمكن صيانتها داخل الجهاز.
- قد ينتج عن استخدام مفاتيح أو تنفيذ عمليات ضبط أو إجراءات بطريقة مختلفة عما هو محدد هنا التعرض لأشعة ليزر في منتهى الخطورة.



خطر

تحتوي بعض منتجات الليزر على صمام ثنائي ليزري مضمن من Class 3A أو Class 3B. لاحظ ما يلي. توجد أشعة ليزر عند الفتح. لا تنظر للشعاع ولا تنظر بطريقة مباشرة باستخدام أدوات ضوئية وتجنب التعرض المباشر للشعاع.



CUIDADO:

Quando produtos a laser (como CD-ROMs, unidades de DVD, dispositivos de fibra ótica ou transmissores) estão instalados, observe o seguinte:

- Não remova as tampas. A remoção das tampas do produto a laser pode resultar em exposição prejudicial à radiação de laser. Não há peças que permitam manutenção no interior do dispositivo.
- A utilização de controles ou ajustes ou a execução de procedimentos diferentes daqueles especificados aqui pode resultar em exposição perigosa à radiação.



PERIGO

Algumas produtos a laser contêm um diodo de laser Classe 3A ou Classe 3B integrado. Observe o seguinte:

Radiação a laser quando aberta. Não olhe diretamente para o feixe a olho nu ou com instrumentos óticos e evite exposição direta ao feixe.



ATTENTION :

Si des produits laser (tels que des unités de CD, DVD, à fibre optique ou des émetteurs) sont installés, lisez les informations suivantes :

- **Ne retirez pas les carters. En ouvrant le produit laser, vous vous exposez au rayonnement dangereux du laser. Aucune pièce de l'unité n'est réparable.**
- **Pour éviter tout risque d'exposition au rayon laser, respectez les consignes de réglage et d'utilisation des commandes, ainsi que les procédures décrites dans le présent manuel.**



DANGER

Certains produits à laser contiennent une diode à laser intégrée de classe 3A ou 3B. Prenez connaissance des informations suivantes.

Rayonnement laser lorsque le carter est ouvert. Evitez toute exposition directe au rayon laser. Evitez de regarder fixement le faisceau ou de l'observer à l'aide d'instruments optiques.



Vorsicht:

Bei der Installation von Lasergeräten (wie CD-ROM-Laufwerken, DVD-Laufwerken, Einheiten mit Lichtwellenleitertechnik oder Sendern) Folgendes beachten:

- Die Abdeckungen nicht entfernen. Durch Entfernen der Abdeckungen des Lasergeräts können gefährliche Laserstrahlungen freigesetzt werden. Das Gerät enthält keine zu wartenden Teile.
- Werden Steuerelemente, Einstellungen oder Durchführungen von Prozeduren anders als hier angegeben verwendet, kann gefährliche Laserstrahlung auftreten.



Gefahr

Einige Lasergeräte enthalten eine Laserdiode der Klasse 3A oder 3B. Beachten Sie Folgendes:

Laserstrahlung bei geöffneter Verkleidung. Nicht in den Strahl blicken. Keine Lupen oder Spiegel verwenden. Strahlungsbereich meiden.



זהירות:

כאשר מוצרי לייזר (כגון תקליטורים, כונני DVD, התקני סיבים אופטיים או משדרים) מותקנים, שימו לב להנחיות הבאות:

- אל תסירו את הכיסויים. הסרת הכיסויים של מוצר הלייזר עלולה לגרום לחשיפה מסוכנת לקרינת לייזר. ההתקן אינם כוללים רכיבים להחלפה עצמית.
- שימוש בבקורות ובהתאמות שלא צוינו או ביצוע תהליכים שלא צוינו, יכולים לגרום לחשיפה מסוכנת לקרינה.



סכנה

כמה ממוצרי הלייזר מכילים דיודת לייזר מובנית Class 3A או Class 3B. שימו לב לדברים שלהלן. קיימת פליטת קרני לייזר כאשר המוצר פתוח. אל תבישו ישירות אל הקרן, אל תבישו אל הקרן ישירות דרך אמצעים אופטיים, והימנעו מחשיפה ישירה לקרן.



警告：

レーザー製品 (CD-ROM、DVD ドライブ、光ファイバー装置、または送信機など) を取り付ける場合には、以下のことに注意してください。

- カバーを外さないこと。カバーを取り外すと有害なレーザー光を浴びることがあります。この装置の内部には保守が可能な部品はありません。
- 本書で指定された内容以外の、お客様による整備、調整、または手順を行った場合、レーザー放射の危険があります。



危険

一部のレーザー製品には、クラス 3A またはクラス 3B のレーザー・ダイオードが組み込まれています。次の点に注意してください。

開けるとレーザー光が放射されます。光線を見つめたり、光学機械を使って直接見たり、光線を直接浴びることは避けてください。



경고：

레이저 제품 (CD-ROM, DVD 드라이브, 광섬유 장치 또는 송신기) 이 설치되어 있는 경우, 다음과 같은 취급 주의사항을 참고하십시오.

- 덮개를 제거하지 마십시오. 레이저 제품의 덮개를 제거하면 유해한 레이저 복사에 노출될 위험이 있습니다. 장치 내부에는 사용자가 수리할 수 있는 부분이 없습니다.
- 본 내용에서 설명한 이외의 방법으로 드라이브를 조정하거나 제어 또는 작동하는 경우, 해로운 레이저 복사에 노출될 수 있습니다.



위험

일부 레이저 제품은 임베디드 클래스 3A 또는 클래스 3B 레이저 다이오드가 포함되어 있습니다. 다음 주의사항을 유의하십시오.

드라이브의 덮개를 열면 전자파가 발생합니다. 광선 또는 광 장치를 직접 보거나 광선에 노출되지 않도록 주의하십시오.



PRECAUCIÓN:

Cuando haya instalados productos láser (por ejemplo, unidades de CD-ROM, unidades de DVD, dispositivos de fibra óptica o transmisores), tenga en cuenta lo siguiente:

- No extraiga las cubiertas. La extracción de las cubiertas del producto láser podría producir una exposición a radiación láser peligrosa. No hay ninguna pieza dentro del dispositivo que pueda reparar.
- La utilización de controles, ajustes o la realización de procedimientos diferentes a los especificados puede dar como resultado una exposición peligrosa a radiaciones.



PELIGRO

Algunos productos láser contienen un diodo láser de Clase 3A o Clase 3B incorporado. Tenga en cuenta lo siguiente.

Emite radiación láser cuando está abierto. No fije la vista en el rayo, no lo mire directamente con instrumentos ópticos y evite la exposición directa al rayo.



警告：

安裝雷射產品（如 CD-ROM、DVD 光碟機、光纖裝置或轉送器）時，請注意下列事項：

- 請勿卸下外蓋。卸下雷射產品的外蓋可能導致曝露於危險的雷射輻射。裝置內沒有可維修的零件。
- 若不遵守本文規定的控制、調整或操作程序，可能會導致危險的輻射外洩。



危險

某些雷射產品包含內嵌式 3A 類或 3B 類雷射二極體。這類光碟機的使用者應注意下列聲明。

在開啟光碟機時，會有雷射輻射。請勿直視光束或以光學儀器直接觀看光束，並避免直接暴露在光束中。

Chapter 2. Important service information

This chapter presents the following important service information that applies to all machine types supported by this manual:

- “Strategy for replacing FRUs” on page 27
 - “Strategy for replacing a hard disk drive” on page 28
 - “Important notice for replacing a system board” on page 28
- “Important information about replacing RoHS compliant FRUs” on page 28

Important: BIOS and device driver fixes are customer-installable. The BIOS and device drivers are available at <http://www.lenovo.com/support>.

Strategy for replacing FRUs

Before replacing parts:

Make sure that all software fixes, drivers, and BIOS downloads are installed before replacing any FRUs listed in this manual.

After a system board is replaced, ensure that the latest BIOS is installed to the system board before completing the service action.

To download software fixes, drivers, and BIOS, do the following:

1. Go to <http://www.lenovo.com/support>.
2. Click **Download Drivers & Software**. The Web site offers three options to begin your search:
 - Search by product number
 - Search through the product auto-detect function
 - Search by product category
3. Follow the directions on the screen and install the necessary software.
4. Restart the computer.

Notes: If you need to improve the computer performance, you also could download and install the latest BIOS utility from the Support Web site.

- Do not try to update the BIOS settings for any computer unless you have been trained and certified. An untrained person runs the risk of damaging the computer.
- Before installing the latest utility, make sure that the battery is fully charged and an ac power adapter is connected.
- Do not turn off or put your computer into sleep or hibernation until the update has been completed. Otherwise, the system board might be damaged.

Use the following strategy to prevent unnecessary expense for replacing and servicing FRUs:

- **If you are instructed to replace a FRU but the replacement does not correct the problem, reinstall the original FRU before you continue.**
- Some computers have both a processor board and a system board. If you are instructed to replace either the processor board or the system board, and replacing one of them does not correct the problem, reinstall that board, and then replace the other one.

- If an adapter or a device consists of more than one FRU, any of the FRUs may be the cause of the error. Before replacing the adapter or device, remove the FRUs, one by one, to see if the symptoms change. Replace only the FRU that changed the symptoms.

Strategy for replacing a hard disk drive

Always try to run a low-level format before replacing a hard disk drive (HDD). This will cause all customer data on the hard disk to be lost. Be sure that the customer has a current backup of the data before doing this task.

Attention: The drive startup sequence in the computer you are servicing may have been changed. Be extremely careful during write operations such as copying, saving, or formatting. If you select an incorrect drive, data or programs can be overwritten.

Important notice for replacing a system board

Some components mounted on a system board are very sensitive. Improper handling of a system board can cause damage to those components, and may cause a system malfunction.

Attention: When handling a system board:

- Do not drop a system board or apply any excessive force to it.
- Avoid rough handling of any kind.
- Avoid bending a system board and hard pushing to prevent cracking at each BGA (Ball Grid Array) chipset.

Important information about replacing RoHS compliant FRUs

RoHS, The Restriction of Hazardous Substances in Electrical and Electronic Equipment Directive (2002/95/EC) is a European Union legal requirement affecting the global electronics industry. RoHS requirements must be implemented on Lenovo products placed on the market after June 2006. Products on the market before June 2006 are not required to have RoHS compliant parts. If the original FRU parts are non-compliant, the replacement parts also can be non-compliant. That is, if the original FRU parts are RoHS compliant, the replacement part also must be RoHS compliant.

Note: RoHS and non-RoHS FRU part numbers with the same fit and function are identified by the unique FRU part numbers.

Lenovo plans to transit to RoHS compliance before the implementation date and expects its suppliers to be ready to meet Lenovo's requirements and schedule in the European Union. Products sold between 2005 and 2006 might contain some RoHS compliant FRUs. The following statement pertains to the products with RoHS compliant FRUs.

RoHS compliant FRUs have unique FRU part numbers. Before or after the RoHS implementation date, the failed RoHS compliant parts must be replaced with compliant parts and only the following FRUs can be used: identified as compliant in the *Hardware Maintenance Manual* or direct substitutions can be used.

- Compliant FRUs identified in *Hardware Maintenance Manual*
- Direct substitutions with different FRU part numbers automatically shipped by the distribution center at the time of order

For products shipped after June 2006

Current or original part	Replacement FRU
Must be RoHS	Must be RoHS

Chapter 3. General checkout

This chapter presents following information:

- “What to do first” on page 29
- “Power system checkout” on page 30

Before you go to the checkout guide, be sure to read the following important notes.

Important notes:

- **Only certified trained personnel should service the computer.**
- **Before replacing any FRU, read the entire page on removing and replacing FRUs.**
- **When you replace FRUs, it is recommended to use new nylon-coated screws.**
- **Be extremely careful during such write operations as copying, saving, or formatting.** Drives in the computer that you are servicing sequence might have been altered. If you select an incorrect drive, data or programs might be overwritten.
- **Replace a FRU only with another FRU of the correct model.** When you replace a FRU, make sure that the model of the machine and the FRU part number are correct by referring to the FRU parts list.
- **A FRU should not be replaced because of a single, unreproducible failure.** Single failures can occur for a variety of reasons that have nothing to do with a hardware defect, such as cosmic radiation, electrostatic discharge, or software errors. Consider replacing a FRU only when a problem recurs. If you suspect that a FRU is defective, clear the error log and run the test again. If the error does not recur, do not replace the FRU.
- **Be careful not to replace a nondefective FRU.**

What to do first

When you do return a FRU, you must include the following information in the parts exchange form or parts return form that you attach to it:

1. Name and phone number of service technician
2. Date of service
3. Date on which the machine failed
4. Date of purchase
5. Procedure index and page number in which the failing FRU was detected
6. Failing FRU name and part number
7. Machine type, model number, and serial number
8. Customer's name and address

Note: During the warranty period, the customer may be responsible for repair costs if the computer damage was caused by misuse, accident, modification, unsuitable physical or operating environment, or improper maintenance by the customer. Following is a list of some common items that are not covered under warranty and some symptoms that might indicate that the system was subjected to stress beyond normal use.

Before checking problems with the computer, determine whether the damage is covered under the warranty by referring to the following list:

The following are not covered under warranty:

- LCD panel cracked from the application of excessive force or from being dropped
- Scratched (cosmetic) parts
- Distortion, deformation, or discoloration of the cosmetic parts
- Plastic parts, latches, pins, or connectors that have been cracked or broken by excessive force
- Damage caused by liquid spilled into the system
- Damage caused by the improper insertion of a PC Card or the installation of an incompatible card
- Improper disc insertion or use of an optical drive

- Diskette drive damage caused by pressure on the diskette drive cover, foreign material in the drive, or the insertion of a diskette with multiple labels
- Damaged or bent diskette eject button
- Fuses blown by attachment of a nonsupported device
- Forgotten computer password (making the computer unusable)
- Sticky keys caused by spilling a liquid onto the keyboard
- Use of an incorrect ac power adapter on laptop products

The following symptoms might indicate damage caused by nonwarranted activities:

- Missing parts might be a symptom of unauthorized service or modification.
- If the spindle of a hard disk drive becomes noisy, it may have been subjected to excessive force, or dropped.

Power system checkout

To verify a symptom, do the following:

1. Turn off the computer.
2. Remove the battery pack.
3. Connect the ac power adapter.
4. Check that power is supplied when you turn on the computer.
5. Turn off the computer.
6. Disconnect the ac power adapter and install the charged battery pack.
7. Check that the battery pack supplies power when you turn on the computer.

If you suspect a power problem, see the appropriate one of the following power supply checkouts:

- “Checking the ac power adapter” on page 30
- “Checking operational charging” on page 31
- “Checking the battery pack” on page 31

Checking the ac power adapter

You are here because the computer fails only when the ac power adapter is used.

- If the power-on indicator does not turn on, check the power cord of the ac power adapter for correct continuity and installation.
- If the computer does not charge during operation, go to “Checking operational charging” on page 31

To check the ac power adapter, do the following:

1. Unplug the ac power adapter cable from the computer.
2. Measure the output voltage at the plug of the ac power adapter cable. See the following figure:

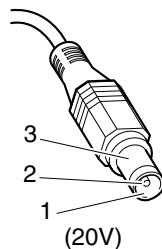

Pin	Voltage (V dc)
1	+20
2	0

Note: Output voltage of pin no.2 of the ac power adapter may differ from the one you are servicing.

3. If the voltage is not correct, replace the ac power adapter.
4. If the voltage is acceptable, do the following:
 - Replace the system board.
 - If the problem persists, go to Chapter 5 “Lenovo B590” on page 37.

Note: Noise from the ac power adapter does not always indicate a defect.

Checking operational charging

To check whether the battery charges properly during operation, use a discharged battery pack or a battery pack that has less than 50% of the total power remaining when installed in the computer.

Perform operational charging. If the battery status indicator or icon does not turn on, remove the battery pack and let it return to room temperature. Reinstall the battery pack. If the charge indicator or icon still does not turn on, replace the battery pack.

If the charge indicator still does not turn on, replace the system board. Then reinstall the battery pack. If it is still not charged, go to the next section.

Checking the battery pack

Battery charging does not start until the power meter shows that less than 95% of the total power remains; under this condition the battery pack can charge to 100% of its capacity. This protects the battery pack from being overcharged or from having a shortened life.

To check your battery, depending on the operating system you are using, do the following:

- Windows 7: Launch the Power Manager program and click the **Battery** tab.
- Windows 8:
 - Press the recovery button to launch the Lenovo Solution Center program, and then click **Battery**.
 - Open the Lenovo Settings program, and then click **Power**.

Note: If the battery pack becomes hot, it may not be able to be charged. Remove it from the computer and leave it at room temperature for a while. After it cools down, reinstall and recharge it.

To check the battery pack, do the following:

1. Power off the computer.
2. Remove the battery pack and measure the voltage between battery terminals 1 (+) and 7 (-).

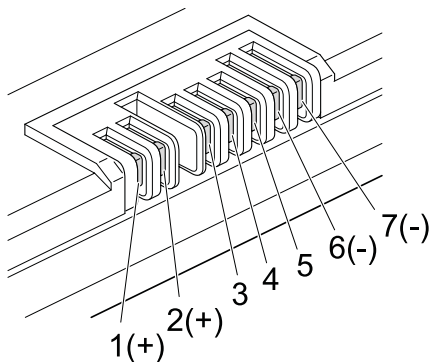

Terminal	Voltage (V dc)
1	+ 0 to + 14
7	Ground (-)

3. If the voltage is less than +11.0 V dc, the battery pack has been discharged.

Note: Recharging will take at least 3 hours, even if the indicator does not turn on.

If the voltage is still less than +11.0 V dc after recharging, replace the battery.

4. If the voltage is more than +11.0 V dc, measure the resistance between battery terminals 5 and 7. The resistance must be 4 to 30 K Ω .

If the resistance is not correct, replace the battery pack. If the resistance is correct, replace the system board.

Chapter 4. Related service information

This chapter presents the following information:

- “Recovering the computer settings” on page 33
- “Passwords” on page 33
- “Power management” on page 34

Recovering the computer settings

This topic provides information about the recovery programs that are available for you to recover the computer settings.

- Windows 7: The following recovery programs are available on computers with a Windows 7 operating system:

- OneKey® Recovery Pro

The OneKey Recovery Pro program enables you to back up all your hard disk drive contents, including the operating system, data files, software programs, and personal settings. You can designate where the OneKey Recovery Pro program stores the backup. After you have backed up the contents on the hard disk drive, you can restore the complete contents of the hard disk drive, restore only the desired files, or restore only the Windows operating system and applications.

- Product Recovery

The Product Recovery program enables you to restore the computer settings to the factory default settings through recovery media.

Attention: When you use the Product Recovery program to restore the computer settings, all the data you have stored on the hard disk drive will be deleted and the computer settings will be restored to the factory default settings. During the restoring process, you will be given the option to save one or more files currently on the hard disk drive to other media before the data is deleted.

- Windows 8: The preinstalled Windows recovery program enables you to do the following:

- Refreshing the computer without losing personal files
- Restoring the computer to the factory default settings

Attention: When you use the Windows recovery program to restore the computer settings, all the data you have stored on the hard disk drive will be deleted and the computer will be restored to the factory default settings. To avoid data loss, back up your data in advance.

- Configuring the advanced startup options

The advanced startup options enable you to do the following:

- Changing the startup settings of the Windows operating system
- Restoring the Windows operating system from a system image
- Starting up from an external device

For more information about the recovery solutions, refer to the help information system of the programs.

Passwords

As many as two passwords might be needed for a Lenovo notebook computer: the power-on password and the supervisor password.

If any of these passwords has been set, a prompt for it will be displayed on the screen whenever the computer is turned on. The computer does not start until the password is entered.

Note: If only a supervisor password is set, the password prompt will not be displayed when the operating system is started.

Power-on password

A power-on password protects the system from being turned on by an unauthorized person. The password must be entered before an operating system can be started.

Supervisor password

A supervisor password protects the system information stored in the BIOS. The user must enter the supervisor password to get access to the BIOS and change the system configuration.

Attention: If you forget the password, there is no service procedure to reset the password. The system board must be replaced for a scheduled fee.

Power management

Note: Power management modes are not supported for APM operating system.

To reduce power consumption, the computer has three power management modes: screen blank, sleep, and hibernation.

Screen blank mode

In the following circumstances, the computer goes into screen blank mode:

- The time set on the “Turn off monitor” timer on the Windows 7 operating system expires.
To end screen blank mode and resume normal operation, press any key.
- You have pressed Fn+F2.
To end screen blank mode and resume normal operation, press Fn+F2.

Sleep mode

When the computer enters sleep mode, the following events occur in addition to what occurs in screen blank mode:

- The LCD is powered off.
- The hard disk drive is powered off.
- The CPU stops.

To enter sleep mode, press Fn+F1.

In certain circumstances, the computer goes into sleep mode automatically:

- If a “suspend time” has been set on the timer, and the user does not do any operation with the keyboard, the hard disk drive, the parallel connector, or the diskette drive within that time.
- If the battery indicator blinks orange, indicating that the battery power is low.

To cause the computer to return from sleep mode and resume the operation, do one of the following:

- Press the Fn key.
- Open the LCD cover.
- Turn on the power button.

Also, when the time set on the resume timer elapses, the computer automatically returns from sleep mode and resumes operation.

Note: The computer does not accept any input immediately after it enters sleep mode. Wait a few seconds before taking any action to reenter operation mode.

Hibernation mode

In hibernation mode, the following occurs:

- The system status, RAM, VRAM, and setup data are stored on the hard disk drive.
- The system is powered off.

If you have defined one of the following actions as the event that causes the system to go into hibernation mode, perform that action.

- Closing the lid.
- Pressing the power button.

Also, the computer goes into hibernation mode automatically in either of the following conditions:

- If a “hibernation time” has been set on the timer, and if the user does not do any operation with the keyboard, the hard disk drive, the parallel connector, or the diskette drive within that time.
- If the timer conditions are satisfied in suspend mode.

When the power is turned on, the computer returns from hibernation mode and resumes operation. The hibernation file in the boot record on the hard disk drive is read, and system status is restored from the hard disk drive.

Chapter 5. Lenovo B590

This chapter presents the following product-specific service references and parts information:

- “Specifications” on page 37
- “Status indicators” on page 38
- “Fn key combinations” on page 39

Specifications

This topic lists the physical features for the Lenovo B590 models.

Processor

- Windows 7: To view the system properties of your computer, click **Start**, right-click **Computer**; then click **Properties**.
- Windows 8: From the desktop, move the cursor to the top-right or bottom-right corner of the screen to display the charms. Then click **Settings** → **PC info**.

Memory

- Double data rate 3 (DDR3) synchronous dynamic random access memory (SDRAM)

Storage device

- 2.5-inch (7 mm height or 9.5 mm height) hard disk drive
- mSATA solid state drive (on some models for cache only)

Note: If the computer is equipped with both a hard disk drive and an mSATA solid-state drive, do not use the mSATA solid-state drive as a bootable device. The mSATA solid-state drive is used for “cache” function only.

Display

- Size: 15.6 inches (396 mm)
- Resolution:
 - LCD: 1366-by-768
 - External monitor: Maximum 2048-by-1536
- Camera

Keyboard

- 6-row Lenovo keyboard
- Recovery button

Interface

- Combo audio jack (stereo headphone or headset)
- USB 2.0 connectors
- USB 3.0 connectors
- RJ45 Ethernet connector
- HDMI connector

- External monitor connector
- 4-in-1 digital media card reader slot

Optical drive

- 12.7 mm Rambo optical drive (on some models)

Wireless features

- Integrated wireless LAN
- Integrated WiMAX
- 100/1000 Mbps Ethernet communication

Status indicators

This chapter presents the system status indicators that show the status of the computer.

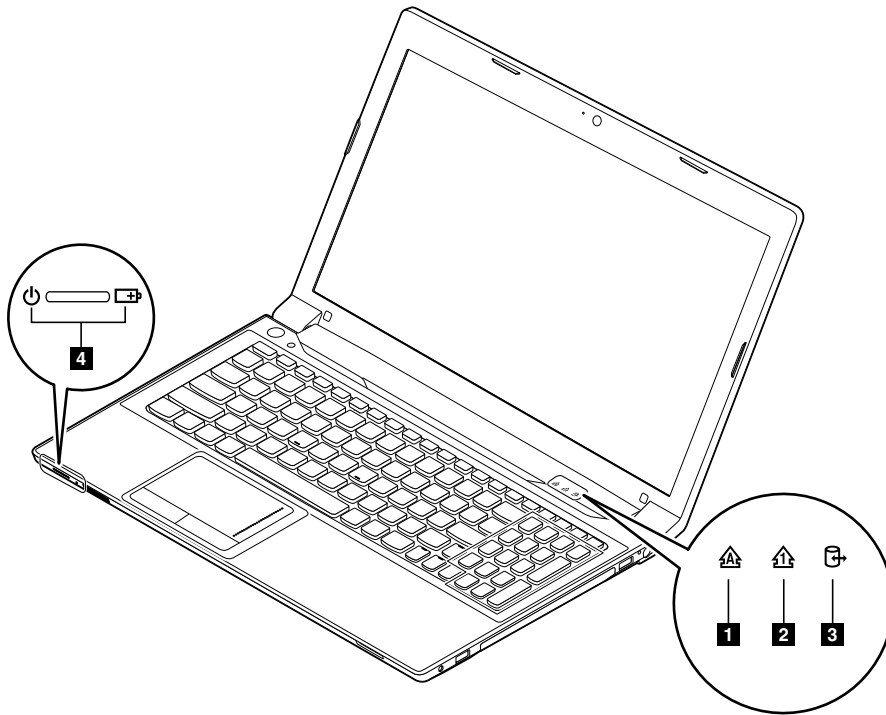

Table 1. Status indicators





Indicator	Meaning
1 Caps Lock status indicator 	White: Caps Lock mode is enabled. You can type all alphabetic characters (A-Z) in uppercase directly. To enable or disable Caps Lock mode, press the Caps Lock key.
2 Numeric Lock status indicator 	White: The separate numeric keypad on the keyboard is enabled. To enable or disable the numeric keypad, press the Numeric Lock key.

Table 1. Status indicators (continued)

Indicator	Meaning
3 Device access status indicator 	<p>On: The hard disk drive or optical drive is reading or writing data.</p> <p>Attention:</p> <ul style="list-style-type: none"> When the indicator is on, do not put the computer into sleep mode or turn off the computer. When the indicator is on, do not move the computer. Sudden physical shock might cause drive errors.
4 Power and battery status indicator 	<ul style="list-style-type: none"> Solid green: The battery charge level is between 80% and 100%, or the battery discharge level is between 20% and 100%. Slow blinking green: The battery charge level is between 20% and 80%, and charging is continuing. When the battery charge level reaches 80%, the battery status indicator stops blinking, but the charging might continue until the battery is 100% charged. Slow blinking orange: The battery charge level is between 5% and 20%, and the charging is continuing. When the battery charge level reaches 20%, the blinking color changes to green. Orange: The battery discharge level is between 5% and 20%. Fast blinking orange: The battery charge or discharge level is 5% or less. Off: The battery is detached or the computer is powered off.

Fn key combinations

The following table describes the functions of Fn key combinations.

Table 2. Function key combinations

Key combination	Description
Fn+Esc	Enables or disables the camera.
Fn+F1	Puts the computer into sleep mode. To resume normal operation, press the Fn key only.
Fn+F2	Enables the backlight feature of the computer screen. To disable the feature, press Fn+F2.
Fn+F3	Switches between the computer display and an external monitor. Note: You also can use the Windows+P combination to switch between the computer display and an external monitor.
Fn+F5	Enables or disables the built-in wireless networking features.
Fn+F6	Enables or disables the touch pad.
Fn+F9	Multimedia control: Start/Pause
Fn+F10	Multimedia control: Stop
Fn+F11	Multimedia control: Skip to the previous track
Fn+F12	Multimedia control: Skip to the next track
Fn+Insert	Has the same function as the ScrLk key on a conventional keyboard.
Fn+PrtSc	Has the same function as the SysRq key on a conventional keyboard.
Fn+Home	Has the same function as the Pause key on a conventional keyboard.
Fn+End	Has the same function as the Break key on a conventional keyboard.

Table 2. Function key combinations (continued)

Key combination	Description
Fn + up/down arrow	Increases or decreases the display brightness level.
Fn + left/right arrow	Decreases or increases the sound volume.

Chapter 6. FRU replacement notices

This chapter presents notices related to removing and replacing parts. Read this chapter carefully before replacing any FRU.

CRU statement for customers:

You can resolve some problems with your product with a replacement part you can install yourself, called a “Customer Replaceable Unit” or “CRU”. Some CRUs are designated as self-service CRUs and others are designated as optional-service CRUs. *Installation of self-service CRUs is your responsibility. For optional-service CRUs, you can either install the CRU yourself or you can request that a Service Provider install the CRU according to the warranty service for your product.* If you intend on installing the CRU, Lenovo will ship the CRU to you. CRU information and replacement instructions are shipped with your product and are available from Lenovo at any time upon request. You can find a list of CRUs for your product in this *Hardware Maintenance Manual*. An electronic version of this manual can be found at <http://www.lenovo.com/UserManuals>. Follow the on-screen instructions to find the manual for your product. You might be required to return the defective CRU. When return is required: (1) return instructions, a prepaid shipping label, and a container will be included with the replacement CRU; and (2) you might be charged for the replacement CRU if Lenovo does not receive the defective CRU within thirty (30) days of your receipt of the replacement CRU. See your Lenovo Limited Warranty documentation for full details.

Screw notices

Loose screws can cause a reliability problem. In the Lenovo notebook computer, this problem is addressed with special nylon-coated screws that have the following characteristics:

- They maintain tight connections.
- They do not easily come loose, even with shock or vibration.
- They are harder to tighten.

Do the following when you service this machine:

- Keep the screw kit in your tool bag.
- It is recommended to use new screws.
- It recommended to use each screw only once.
- Use a torque screwdriver if you have one.

Tighten screws as follows:

- **Plastic to plastic**

Turn an additional **90 degrees** after the screw head touches the surface of the plastic part:

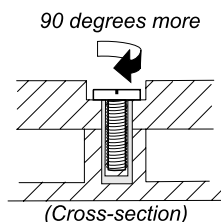

- **Logic card to plastic**

Turn an additional **180 degrees** after the screw head touches the surface of the logic card:

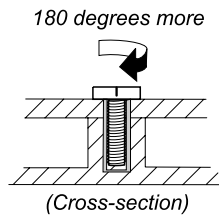

- **Torque driver**

If you have a torque screwdriver, refer to the Torque column in the screw information table for each step.

- Make sure that you use the correct screw. It is recommended to use new screws for replacements. If you have a torque screwdriver, tighten all screws firmly to the torque specified in the screw information table for each step.
- Ensure torque screw drivers are calibrated correctly following country specifications.

Chapter 7. Removing and replacing a FRU

This chapter provides instructions on how to remove or replace a FRU.

CRU statement for customers:

You can resolve some problems with your product with a replacement part you can install yourself, called a “Customer Replaceable Unit” or “CRU”. Some CRUs are designated as self-service CRUs and others are designated as optional-service CRUs. *Installation of self-service CRUs is your responsibility. For optional-service CRUs, you can either install the CRU yourself or you can request that a Service Provider install the CRU according to the warranty service for your product.* If you intend on installing the CRU, Lenovo will ship the CRU to you. CRU information and replacement instructions are shipped with your product and are available from Lenovo at any time upon request. You can find a list of CRUs for your product in this *Hardware Maintenance Manual*. An electronic version of this manual can be found at <http://www.lenovo.com/UserManuals>. Follow the on-screen instructions to find the manual for your product. You might be required to return the defective CRU. When return is required: (1) return instructions, a prepaid shipping label, and a container will be included with the replacement CRU; and (2) you might be charged for the replacement CRU if Lenovo does not receive the defective CRU within thirty (30) days of your receipt of the replacement CRU. See your Lenovo Limited Warranty documentation for full details.

General guidelines

This chapter presents directions and drawings for use in removing and replacing a FRU. Be sure to observe the following general rules:

1. Do not try to service any computer unless you have been trained and certified. An untrained person runs the risk of damaging parts.
2. Before replacing any FRU, review Chapter 6 “FRU replacement notices” on page 41.
3. Begin by removing any FRUs that have to be removed before replacing the failing FRU. Such FRUs are listed in each FRU replacement section. Remove them in the order in which they are listed.
4. Follow the correct sequence in the steps for removing a FRU, as given in the drawings by the numbers in square callouts.
5. When turning a screw, turn it in the direction as given by the arrow in the drawing.
6. When removing a FRU, move it in the direction as given by the arrow in the drawing.
7. To put the new FRU in place, reverse the removal procedure and follow any notes that pertain to replacement.
8. When replacing a FRU, use the correct screw(s) as shown in the procedures.



Before removing any FRU, turn off the computer, unplug all power cords from electrical outlets, remove the battery pack, and then disconnect any interconnecting cables.

Attention: After replacing a FRU, do not turn on the computer until you have made sure that all screws, springs, and other small parts are in place and none are loose inside the computer. Verify this by shaking the computer gently and listening for rattling sounds. Metallic parts or metal flakes can cause electrical short circuits.

Attention: The system board is sensitive to, and can be damaged by, electrostatic discharge. Before touching it, establish personal grounding by touching a ground point with one hand or by using an electrostatic discharge (ESD) strap (P/N 6405959).

1010 Battery pack

Removal steps of battery pack



Use only the battery specified in the parts list for your computer. Any other battery could ignite or explode.

Unlock the spring-loaded battery latch **1**. Holding the manual battery latch in the unlocked position, remove the battery pack in the direction shown by the arrow **2**.

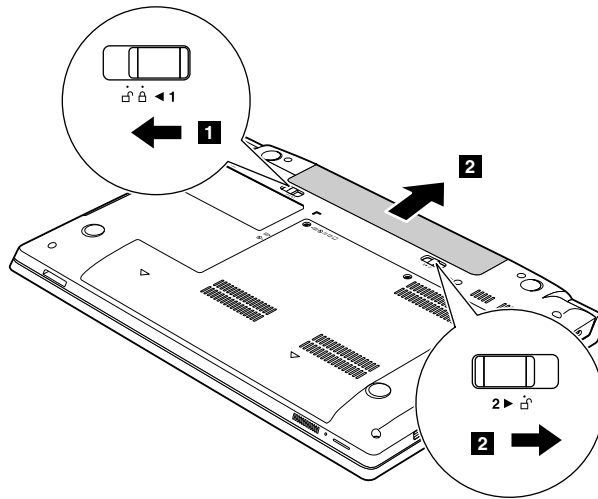

When installing: Install the battery pack in the slot. Make sure that the battery latches are in the locked position.

1020 Bottom slot cover

For access, remove this FRU:

- “1010 Battery pack” on page 44

Removal steps of bottom slot cover

Remove the screws **1**, and then remove the cover **2**.

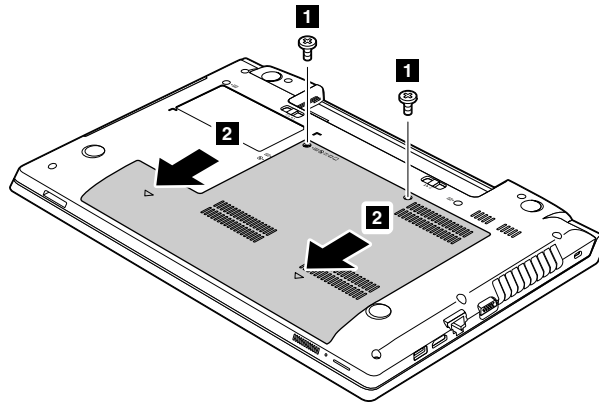

Step	Screw (quantity)	Color	Torque
1	M2 × 3 mm, flat-head, nylon-coated (2)	Black	1.85 kgf-cm

1030 Optical drive

For access, remove these FRUs in order:

- “1010 Battery pack” on page 44
- “1020 Bottom slot cover” on page 44

Removal steps of optical drive

Remove the screw **1**.

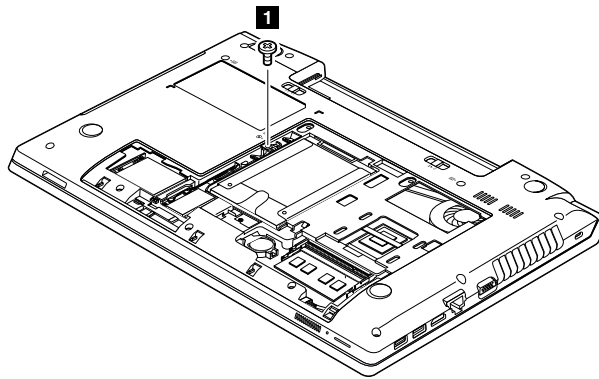

Step	Screw (quantity)	Color	Torque
1	M2 × 3 mm, flat-head, nylon-coated (1)	Black	1.85 kgf-cm

Insert a screwdriver into the screw hole **2** and push the optical drive in the direction shown by the arrow **3**. Then remove the optical drive.

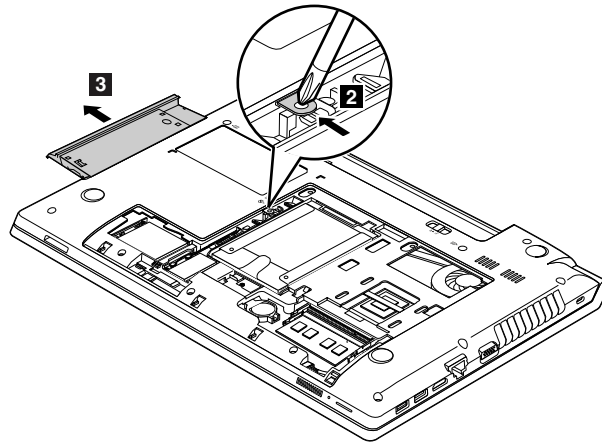

Removal steps of optical drive bezel and optical drive bracket

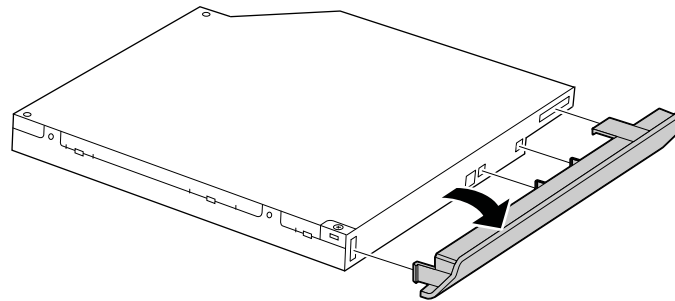

Remove the screws **1** and then remove the optical drive bracket.

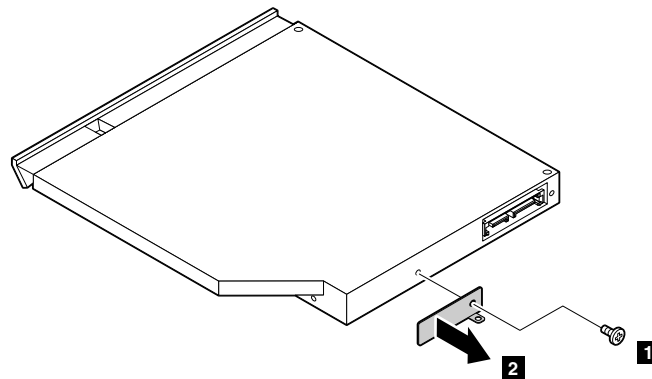

Step	Screw (quantity)	Color	Torque
1	M2 × 3 mm, flat-head, nylon-coated (2)	Black	1.85 kgf-cm

1040 Memory modules

For access, remove these FRUs in order:

- “1010 Battery pack” on page 44
- “1020 Bottom slot cover” on page 44

Removal steps of memory modules

Release the two latches on both edges of the socket at the same time in the direction shown by the arrows **1**, and then unplug the memory module in the direction shown by the arrow **2**.

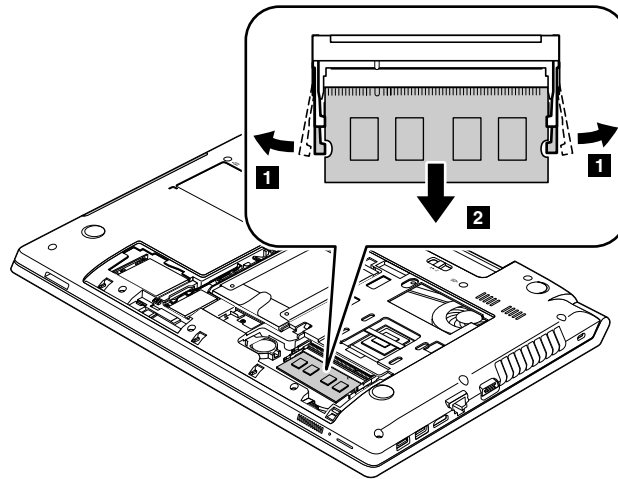

Note: If only one memory module is used on the computer you are servicing, the card must be installed in SLOT-0 (**a**: lower slot), but not in SLOT-1 (**b**: upper slot).

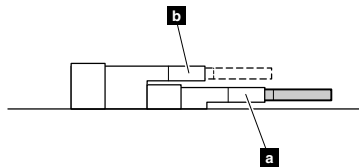

When installing: Insert the notched end of the memory module into the socket. Press the memory module firmly, and pivot it until it snaps into place. Make sure that it is firmly installed in the slot and does not move easily.

1050 Hard disk drive assembly

For access, remove these FRUs in order:

- “1010 Battery pack” on page 44
- “1020 Bottom slot cover” on page 44

Attention:

- Do not drop the drive or apply any physical shock to it. The drive is sensitive to physical shock. Improper handling can cause damage and permanent loss of data.
- Before removing the drive, have the user make a backup copy of all the information on it if possible.
- Never remove the drive while the computer is operating or is in suspend mode.

Removal steps of hard disk drive assembly

Remove the screw **1**, then pull the tab in the direction shown by the arrow **2**.

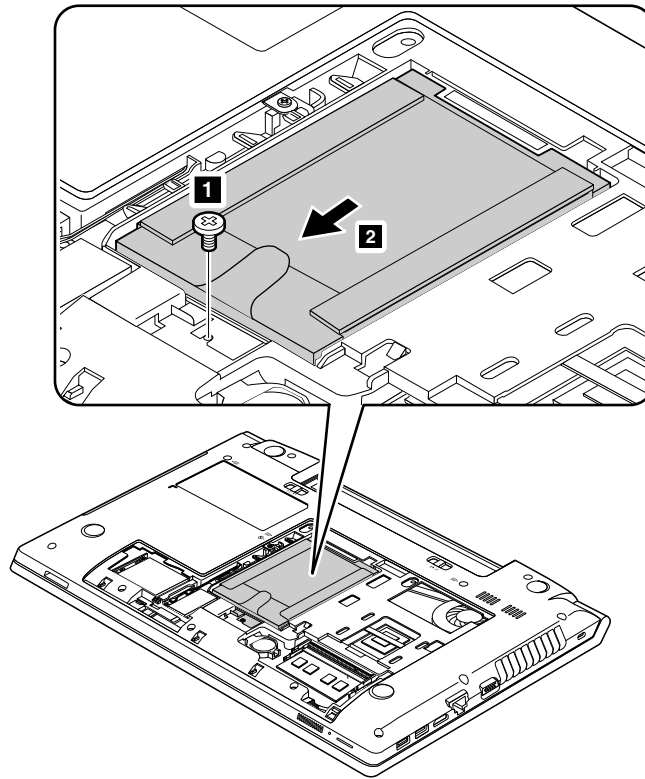

Step	Screw (quantity)	Color	Torque
1	M2 × 3 mm, flat-head, nylon-coated (1)	Black	1.85 kgf-cm

Remove the hard disk drive from the slot **3**.

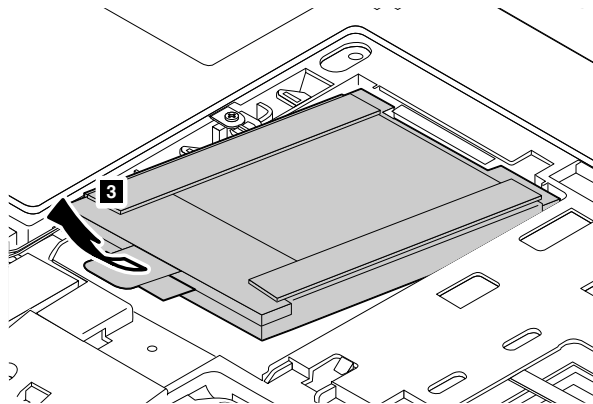

When installing: Ensure that the hard disk drive connector is attached firmly.

Removal steps of hard disk drive bracket

Remove the screws **1**.

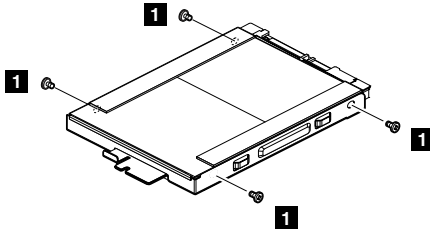

Step	Screw (quantity)	Color	Torque
1	M3 × 4 mm, flat-head, nylon-coated (4)	Silver	4 kgf-cm

Remove the hard disk drive bracket as shown by the arrow **2**.

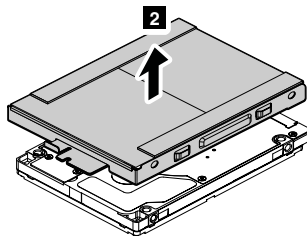

1060 PCI Express Mini Card for wireless LAN

For access, remove these FRUs in order:

- “1010 Battery pack” on page 44
- “1020 Bottom slot cover” on page 44

Removal steps of PCI Express Mini Card for wireless LAN

In steps **1**, disconnect the cables from the card using the removal tool antenna RF connector (P/N: 08K7159) or pick up the cables with your fingers and then gently disconnecting the cable from the card in the direction of the arrows. Then remove the screw **2**.

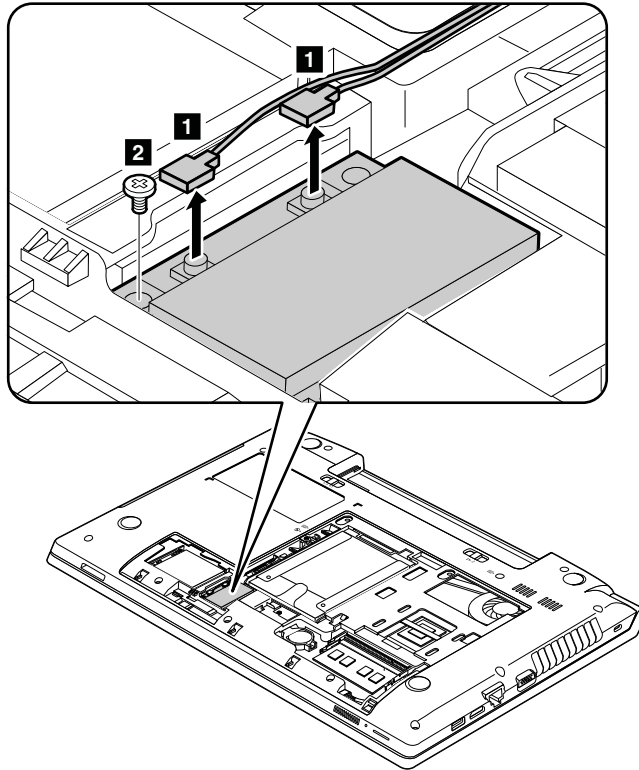

Step	Screw (quantity)	Color	Torque
2	M2 × 3 mm, flat-head, nylon-coated (1)	Black	1.85 kgf-cm

Remove the card in the direction shown by the arrow **3**.

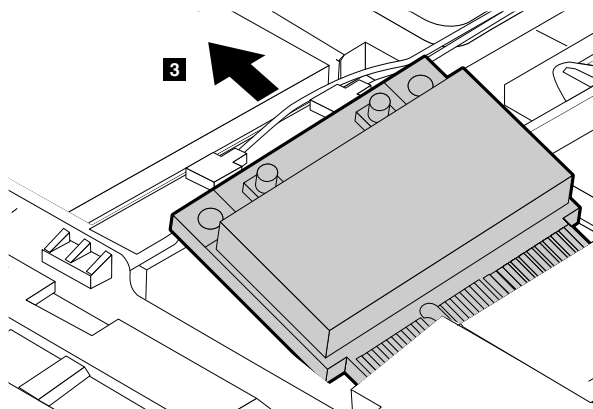

When installing: Plug the black cable (MAIN) into the jack labeled **M**, and the white cable (AUX) into the jack labeled **A** on the card.

1070 mSATA solid state drive

For access, remove these FRUs in order:

- “1010 Battery pack” on page 44
- “1020 Bottom slot cover” on page 44

Attention:

- Do not drop the drive or apply any physical shock to it. The drive is sensitive to physical shock. Improper handling can cause damage and permanent loss of data.
- Before removing the drive, have the user make a backup copy of all the information on it if possible.
- Never remove the drive while the computer is operating or is in suspend mode.

Removal steps of mSATA solid state drive

Remove the screw **1**.

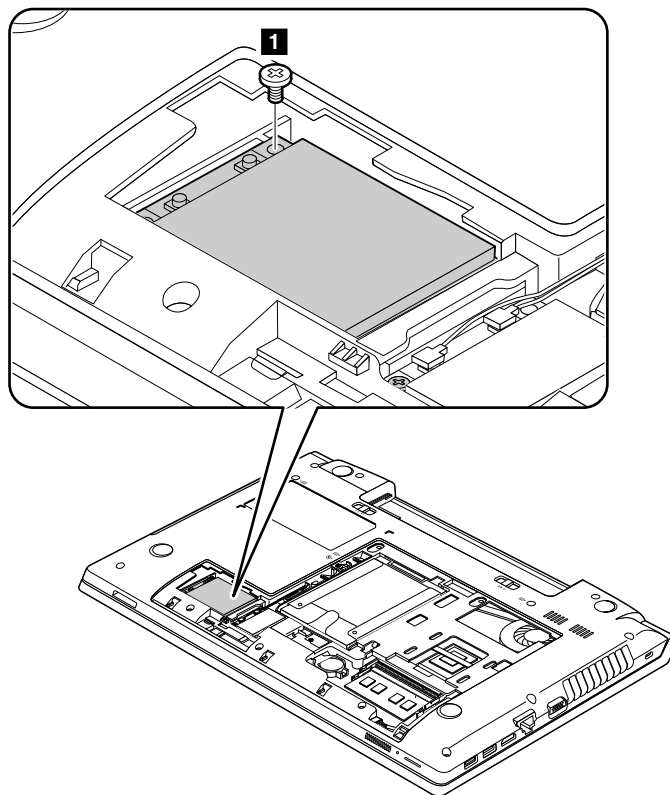

Step	Screw (quantity)	Color	Torque
1	M2 × 3 mm, flat-head, nylon-coated (1)	Black	1.85 kgf-cm

Remove the mSATA solid state drive **2**.

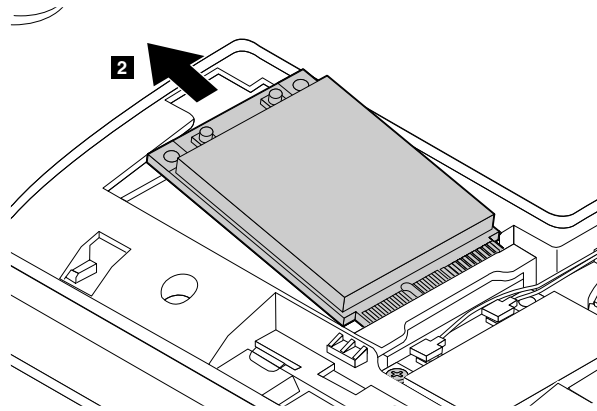

1080 Backup battery

For access, remove these FRUs in order:

- “1010 Battery pack” on page 44
- “1020 Bottom slot cover” on page 44

Removal steps of backup battery



DANGER

Use only the battery specified in the parts list for your computer. Any other battery could ignite or explode.

Insert a screwdriver into the backup battery hole and push the backup battery until the battery pops up.

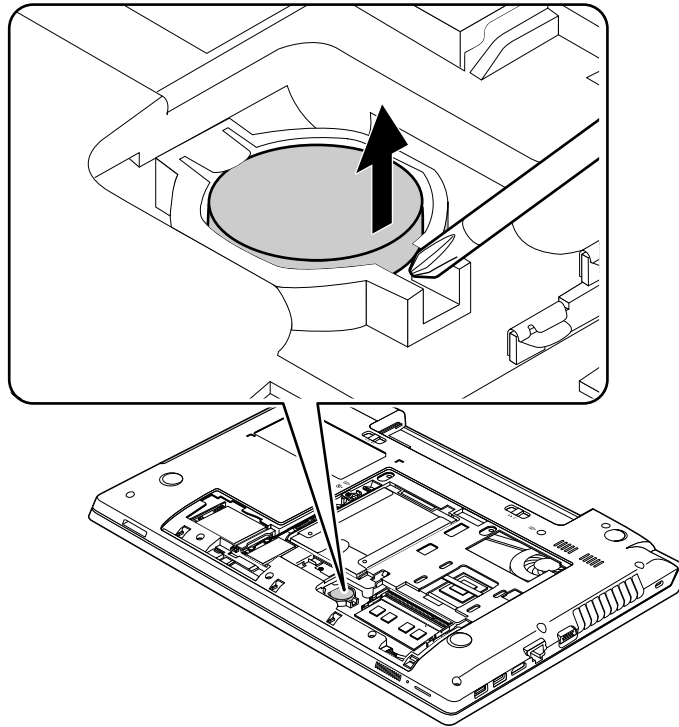

When installing: Ensure that the connector is attached firmly.

1090 Keyboard

For access, remove these FRUs in order:

- “1010 Battery pack” on page 44
- “1020 Bottom slot cover” on page 44

Removal steps of keyboard

Remove the screws **1**.

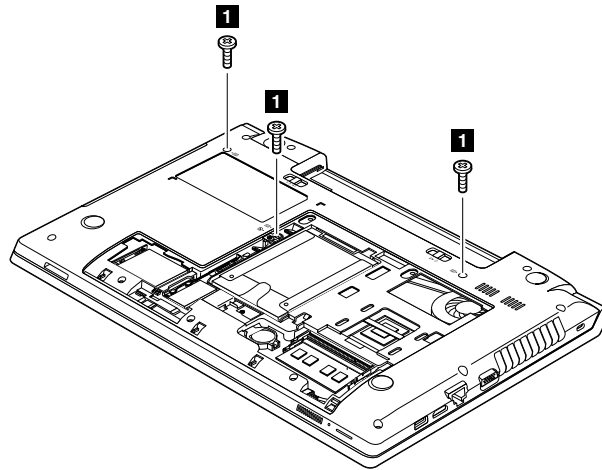

When installing: Ensure that the screws have been fastened to secure the keyboard.

Step	Screw (quantity)	Color	Torque
1	M2.5 × 8 mm, flat-head, nylon-coated (3)	Black	4.0 kgf-cm

Push hard in the direction shown by the arrow **2** to unlatch the front side of the keyboard.

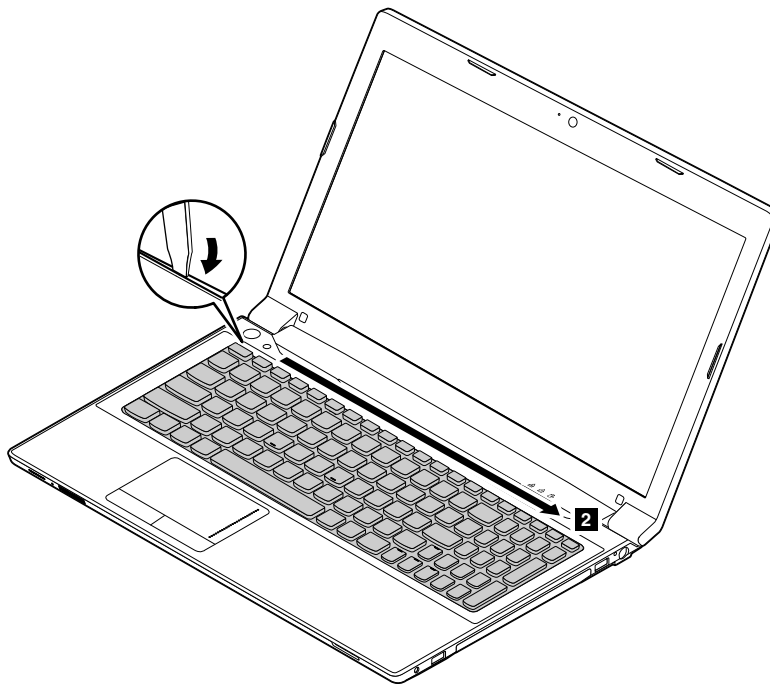

Remove the keyboard in the direction shown by the arrow **3**.

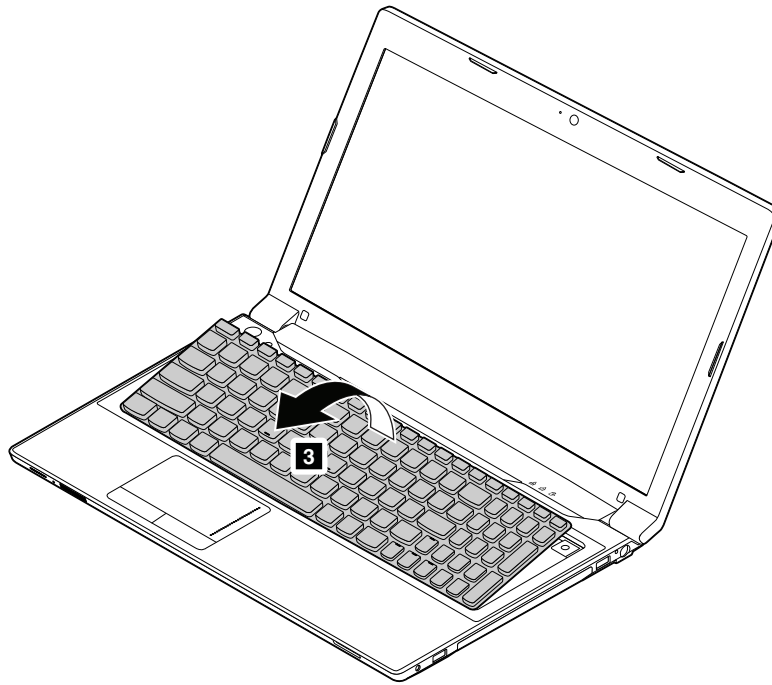

Carefully lift the keyboard until you can see how it's connected. Hold the keyboard above the computer **4**, and then detach the keyboard connector.

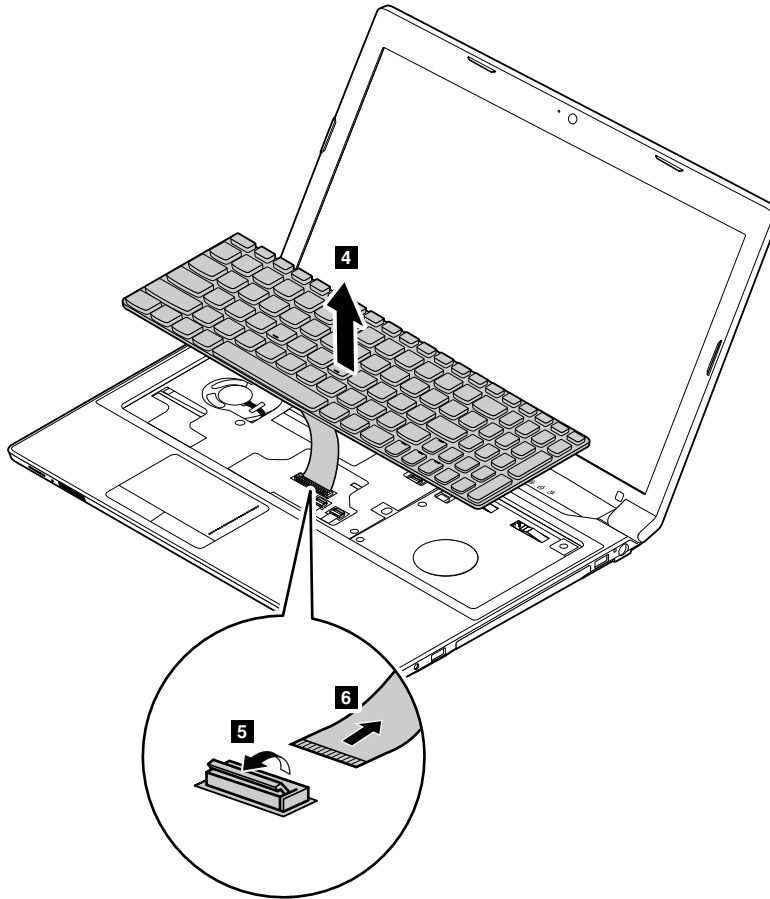

When installing: Ensure that the keyboard connector is attached firmly.

1100 Keyboard bezel

For access, remove these FRUs in order:

- “1010 Battery pack” on page 44
- “1020 Bottom slot cover” on page 44
- “1030 Optical drive” on page 45
- “1090 Keyboard” on page 53

Removal steps of keyboard bezel

Remove the screws **1** and **2** that secure the keyboard bezel.

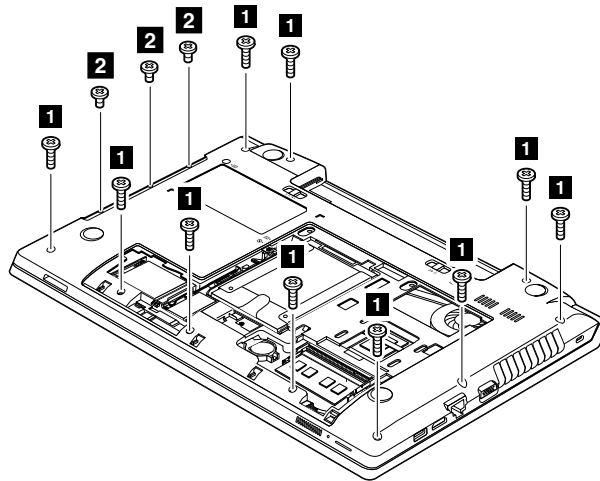

Step	Screw (quantity)	Color	Torque
1	M2.5 × 8 mm, flat-head, nylon-coated (10)	Black	4.0 kgfcm
2	M2 × 3 mm, flat-head, nylon-coated (3)	Black	1.85 kgf-cm

Remove the screws **3**.

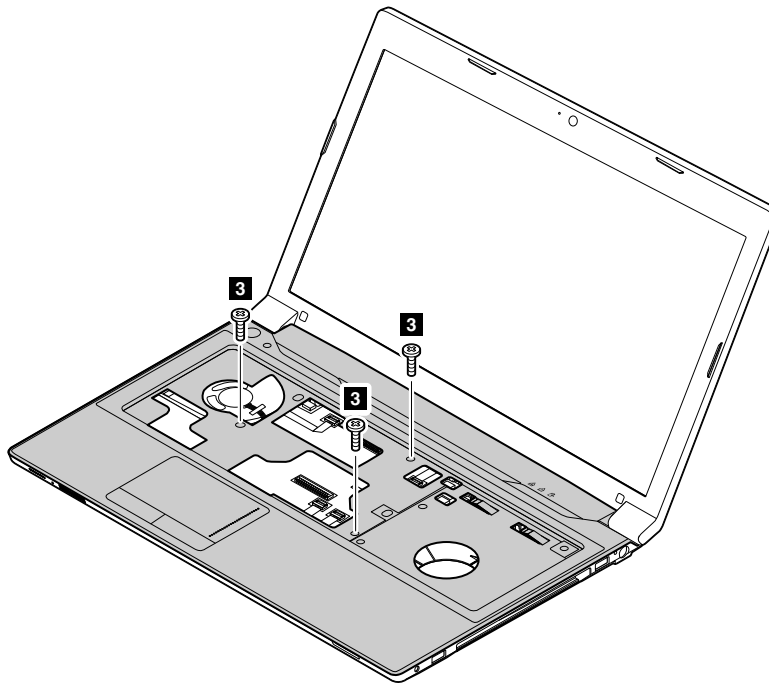

Step	Screw (quantity)	Color	Torque
3	M2 × 5 mm, flat-head, nylon-coated (3)	Black	1.85 kgf-cm

Detach the connectors.

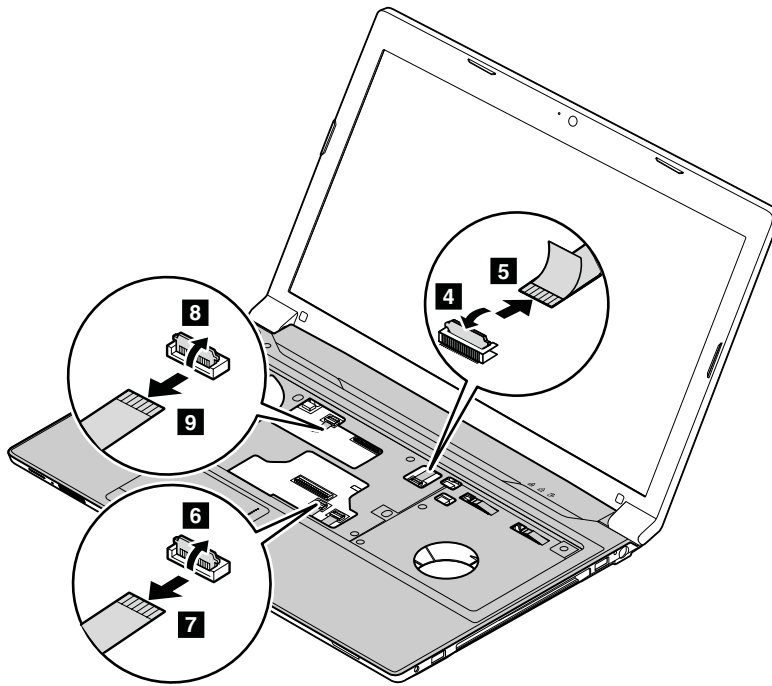

When installing: Ensure that all the connectors are attached firmly.

Remove the keyboard bezel.

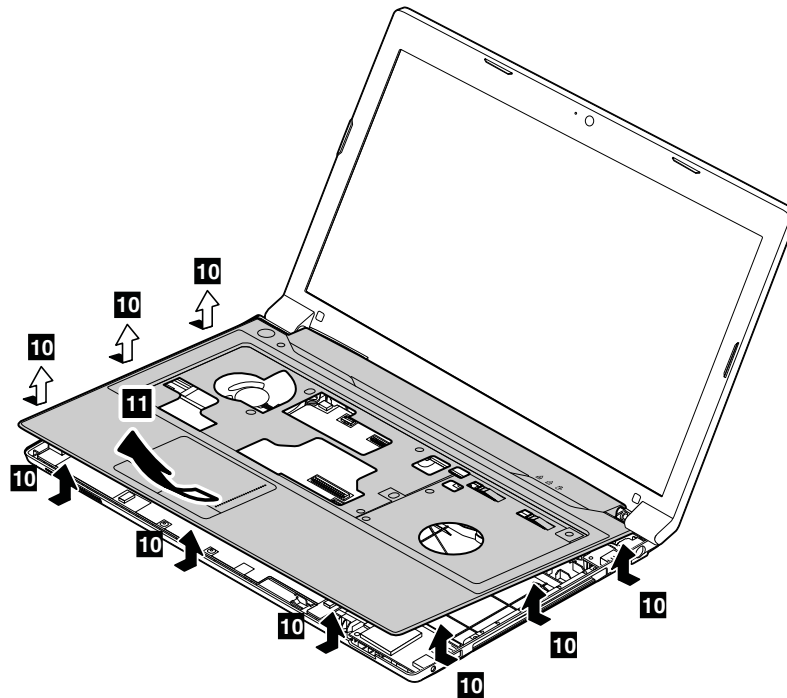

1110 LED board

For access, remove these FRUs in order:

- “1010 Battery pack” on page 44
- “1020 Bottom slot cover” on page 44
- “1030 Optical drive” on page 45
- “1090 Keyboard” on page 53
- “1100 Keyboard bezel” on page 56

Removal steps of LED board

Peel off the mylar tape **1**. Then remove the LED board **2**.

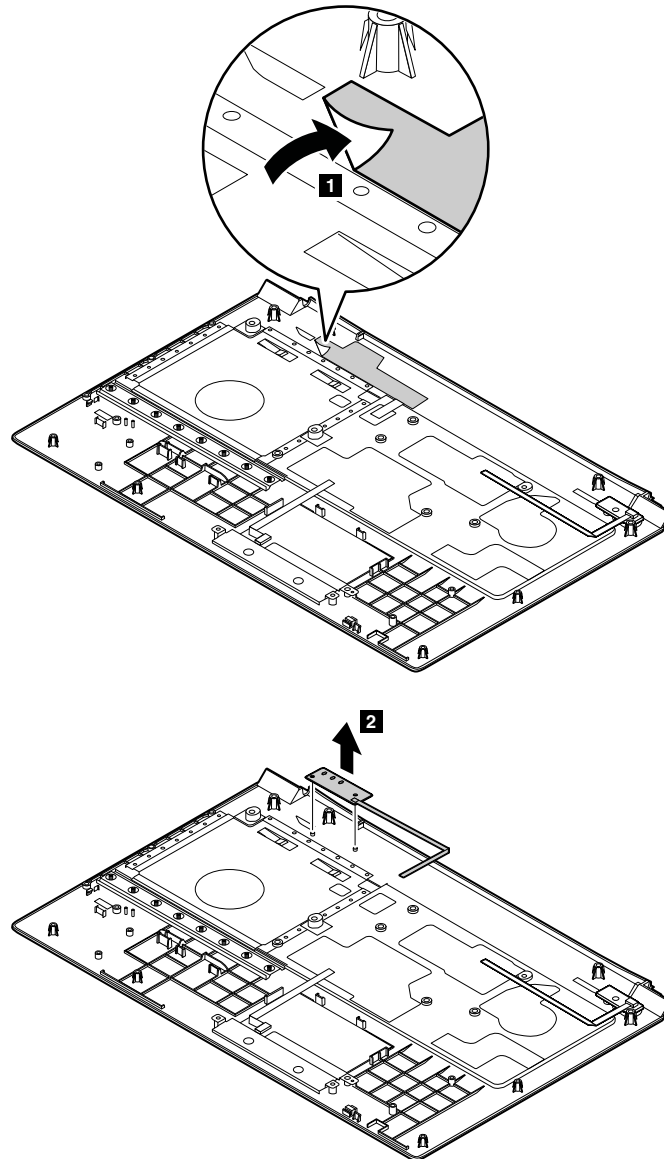

1120 Power board and touch pad bracket

For access, remove these FRUs in order:

- “1010 Battery pack” on page 44
- “1020 Bottom slot cover” on page 44
- “1030 Optical drive” on page 45
- “1090 Keyboard” on page 53
- “1100 Keyboard bezel” on page 56

Removal steps of power board

Remove the screw **1** and then remove the power board **2**.

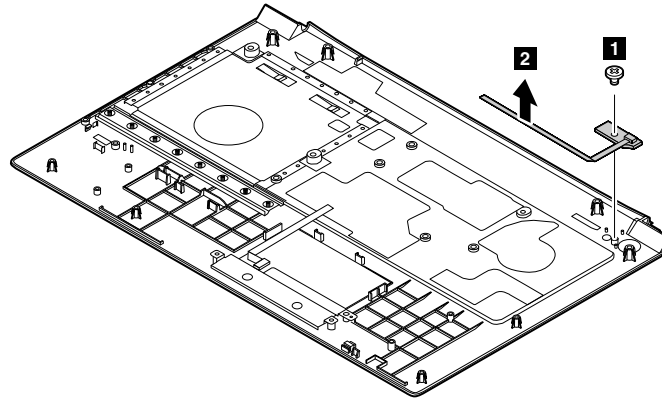

Step	Screw (quantity)	Color	Torque
1	M2 × 3 mm, flat-head, nylon-coated (1)	Black	1.85 kgf-cm

Removal steps of touch pad bracket

Remove the screw **1** and then remove the touch pad bracket **2**.

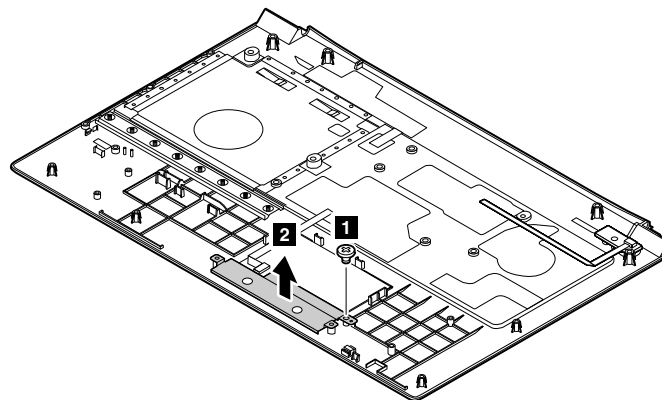

Step	Screw (quantity)	Color	Torque
1	M2 × 3 mm, flat-head, nylon-coated (1)	Black	1.85 kgf-cm

1130 Microphone assembly

For access, remove these FRUs in order:

- “1010 Battery pack” on page 44
- “1020 Bottom slot cover” on page 44
- “1030 Optical drive” on page 45
- “1090 Keyboard” on page 53
- “1100 Keyboard bezel” on page 56

Removal steps of microphone assembly

Detach the connector **1**, and then remove the microphone assembly in the direction shown by the arrow **2**.

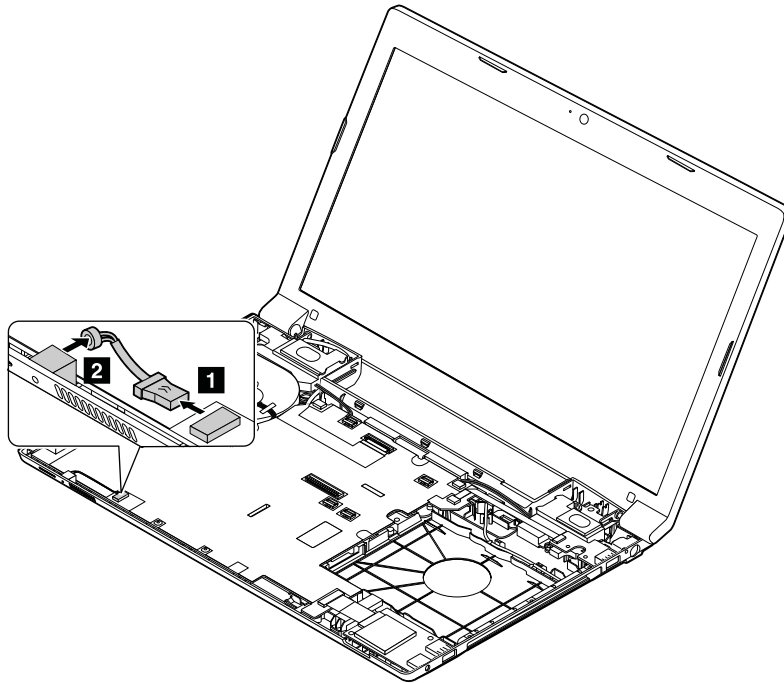

When installing: Ensure that the connector is attached firmly to the system board.

1140 I/O board

For access, remove these FRUs in order:

- “1010 Battery pack” on page 44
- “1020 Bottom slot cover” on page 44
- “1030 Optical drive” on page 45
- “1090 Keyboard” on page 53
- “1100 Keyboard bezel” on page 56

Removal steps of I/O board

Remove the screws **1**, and then detach the cable. Remove the I/O board **4**.

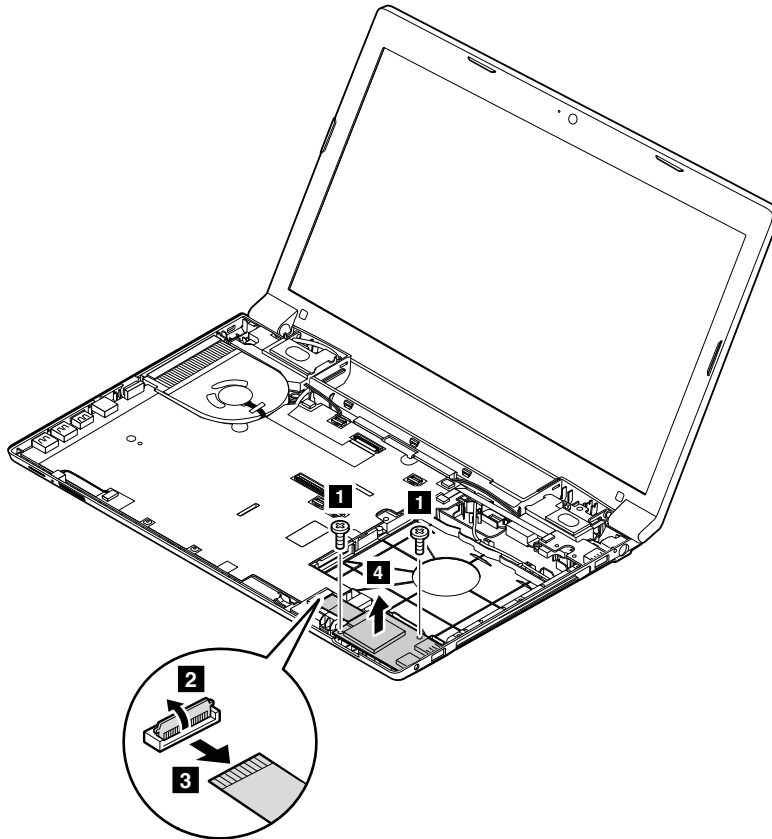

Step	Screw (quantity)	Color	Torque
1	M2 × 5 mm, flat-head, nylon-coated (2)	Black	1.85 kgf-cm

When installing: Ensure that the cable is attached firmly to the system board.

1150 System board assembly and USB board

Important notices for handling the system board:

When handling the system board, bear the following in mind:

- Be careful not to drop the system board on a bench top that has a hard surface, such as metal, wood, or composite.
- Avoid rough handling of any kind.
- At every point in the process, be sure not to drop or stack the system board.
- If you put a system board down, be sure to put it only on a padded surface such as an ESD mat or a corrugated conductive surface.

For access, remove these FRUs in order:

- “1010 Battery pack” on page 44
- “1020 Bottom slot cover” on page 44
- “1030 Optical drive” on page 45
- “1040 Memory modules” on page 46
- “1050 Hard disk drive assembly” on page 47
- “1060 PCI Express Mini Card for wireless LAN” on page 49
- “1070 mSATA solid state drive” on page 51
- “1080 Backup battery” on page 52
- “1090 Keyboard” on page 53
- “1100 Keyboard bezel” on page 56
- “1130 Microphone assembly” on page 60

Removal steps of system board assembly

Remove the screws **1**, and then detach the connectors as shown in the following illustration.

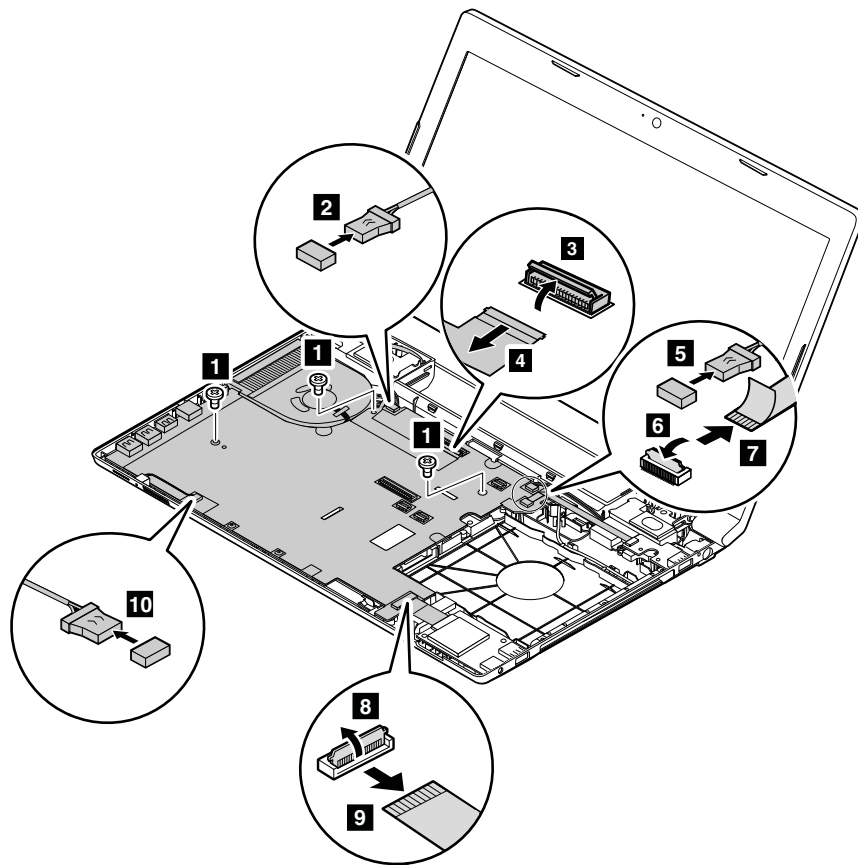

Step	Screw (quantity)	Color	Torque
1	M2 × 5 mm, flat-head, nylon-coated (2)	Black	1.85 kgf-cm

When installing: Ensure that all the connectors are attached firmly.

Detach the DC-in cable **11**. Remove the system board in the direction shown by the arrow **12**.

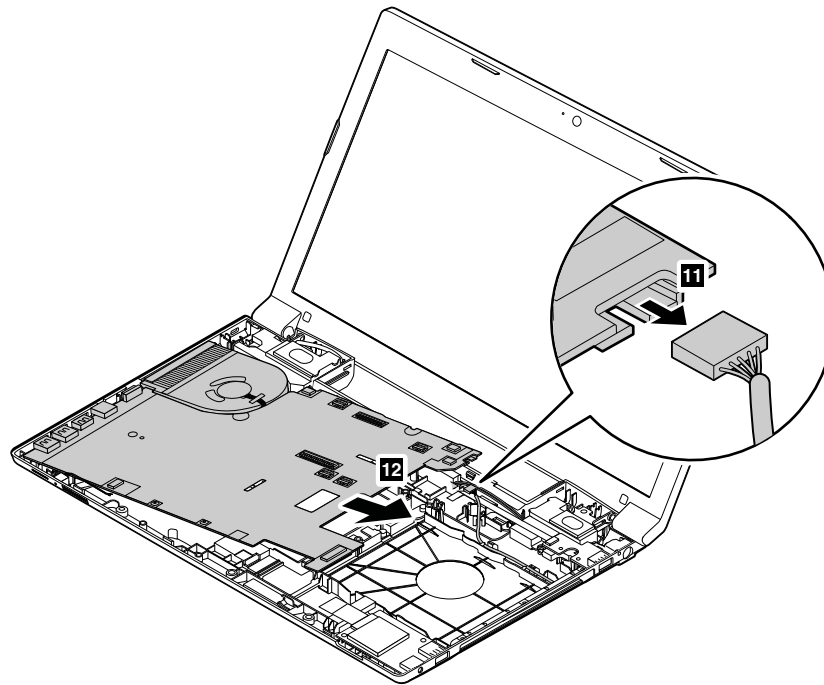

Removal steps of USB board

Remove the screw **1**, and then detach the connectors as shown in the following illustration. Remove the USB board **4**.

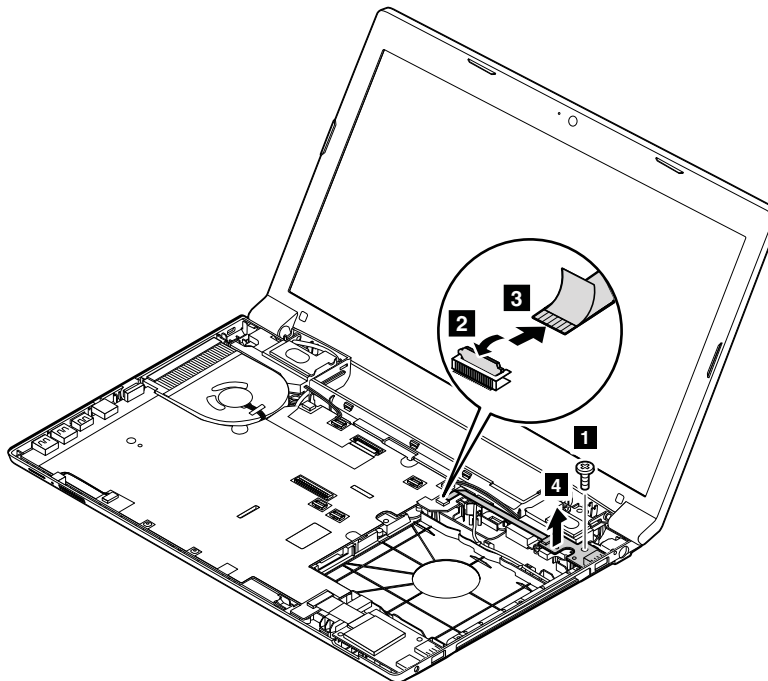

Step	Screw (quantity)	Color	Torque
1	M2 × 5 mm, flat-head, nylon-coated (1)	Black	1.85 kgf-cm

When installing: Ensure that the cable is attached firmly to the system board.

1160 DC-in connector

For access, remove these FRUs in order:

- “1010 Battery pack” on page 44
- “1020 Bottom slot cover” on page 44
- “1030 Optical drive” on page 45
- “1040 Memory modules” on page 46
- “1050 Hard disk drive assembly” on page 47
- “1060 PCI Express Mini Card for wireless LAN” on page 49
- “1070 mSATA solid state drive” on page 51
- “1080 Backup battery” on page 52
- “1090 Keyboard” on page 53
- “1100 Keyboard bezel” on page 56
- “1130 Microphone assembly” on page 60
- “1140 I/O board” on page 61
- “1150 System board assembly and USB board” on page 62

Removal steps of DC-in connector

Detach the connector **1**. Remove the screw **2** and the DC-in connector bracket **3**. Then remove the DC-in connector in the direction shown by the arrow **4**.

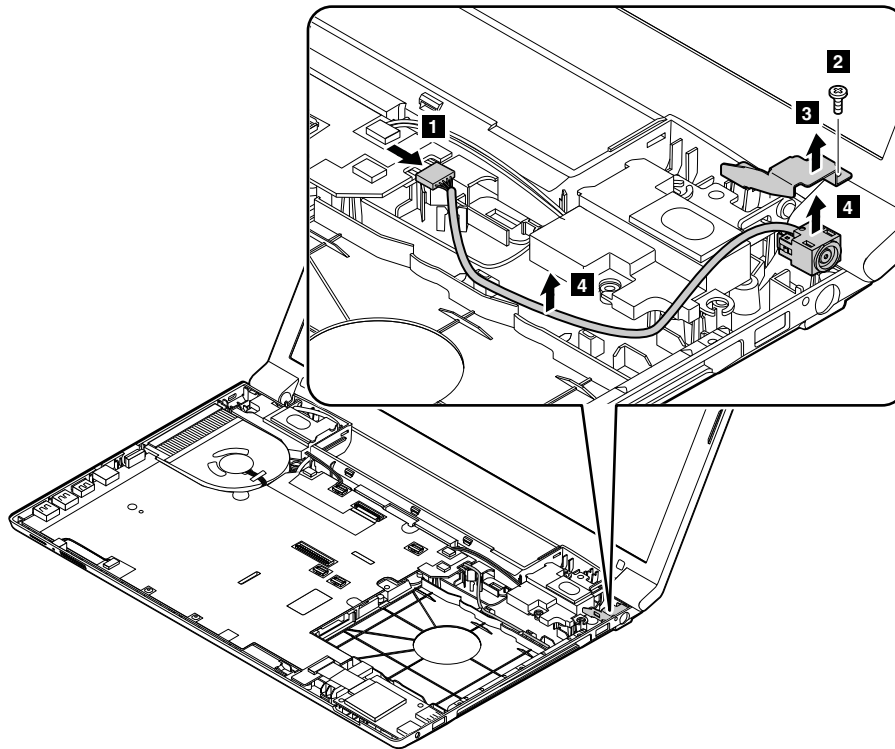

Step	Screw (quantity)	Color	Torque
2	M2.5 × 5 mm, flat-head, nylon-coated (1)	Black	4 kgf-cm

When installing: Ensure that the cable is attached firmly to the system board.

1170 Thermal module

For access, remove these FRUs in order:

- “1010 Battery pack” on page 44
- “1020 Bottom slot cover” on page 44
- “1030 Optical drive” on page 45
- “1040 Memory modules” on page 46
- “1050 Hard disk drive assembly” on page 47
- “1060 PCI Express Mini Card for wireless LAN” on page 49
- “1070 mSATA solid state drive” on page 51
- “1080 Backup battery” on page 52
- “1090 Keyboard” on page 53
- “1100 Keyboard bezel” on page 56
- “1130 Microphone assembly” on page 60
- “1150 System board assembly and USB board” on page 62

Removal steps of thermal module

Detach the fan connector **1**.

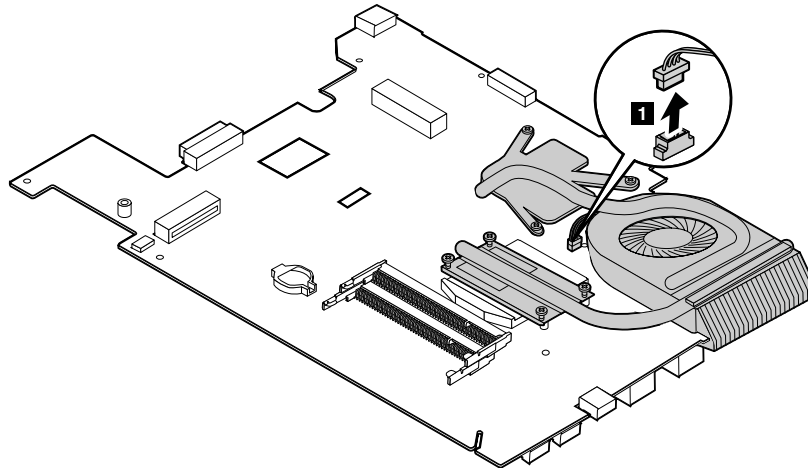

When installing: Ensure that the connector is attached firmly.

Loosen the screws **2** to **8**.

Note: Different models might have different numbers of screws.

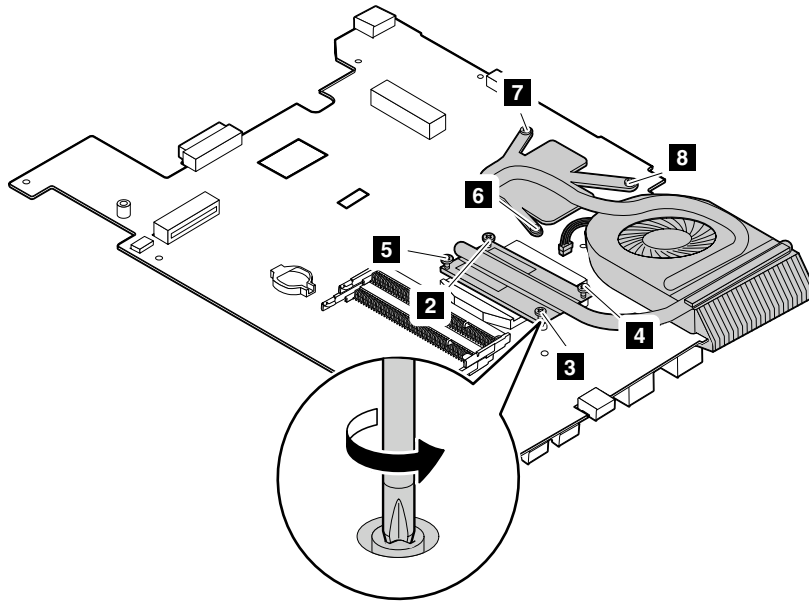

Lift the fan assembly in the direction shown by the arrow **9**.

Note: Be careful not to damage the connector.

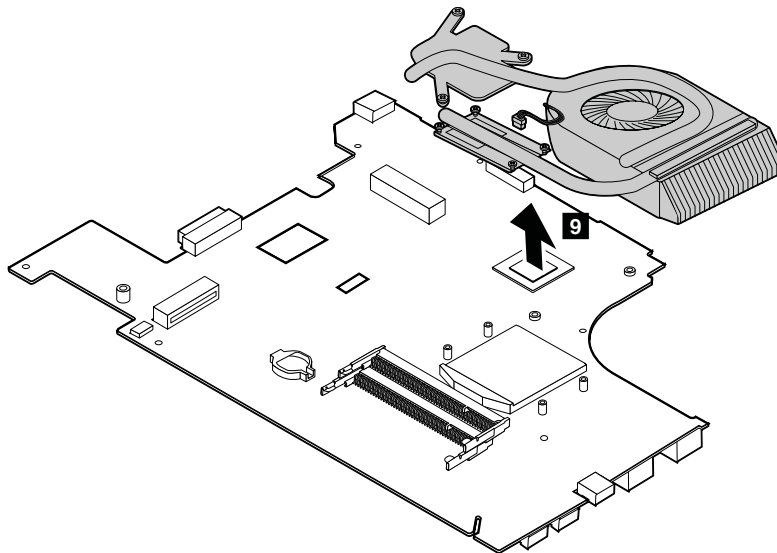

When installing: Before you attach the thermal module to the computer, apply thermal grease, at an amount of 0.2 grams, on the part marked **a** and **b** as shown in the following illustration. Either too much or too less application of grease can cause a thermal problem due to imperfect contact with a component.

For models with a discrete thermal module

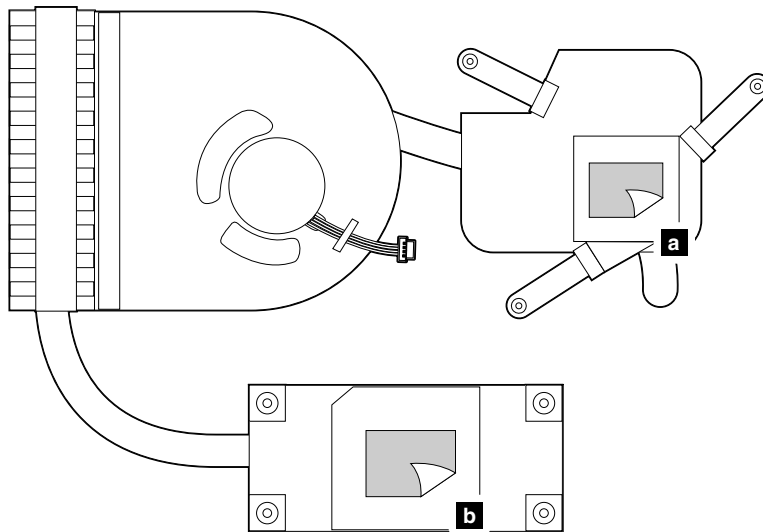

For models with an integrated thermal module

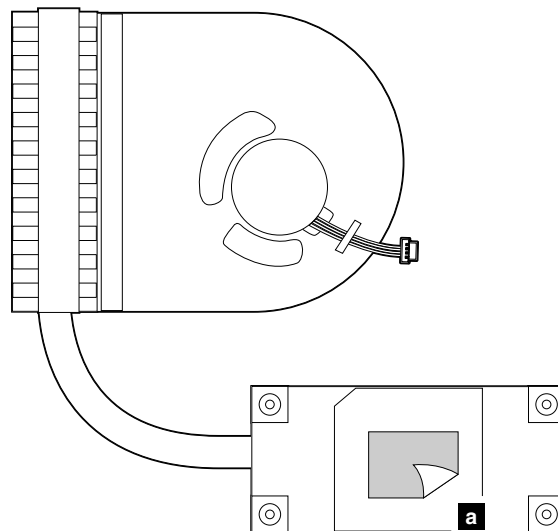

1180 CPU

For access, remove these FRUs in order:

- “1010 Battery pack” on page 44
- “1020 Bottom slot cover” on page 44
- “1030 Optical drive” on page 45
- “1040 Memory modules” on page 46
- “1050 Hard disk drive assembly” on page 47
- “1060 PCI Express Mini Card for wireless LAN” on page 49
- “1070 mSATA solid state drive” on page 51
- “1080 Backup battery” on page 52

- “1090 Keyboard” on page 53
- “1100 Keyboard bezel” on page 56
- “1130 Microphone assembly” on page 60
- “1150 System board assembly and USB board” on page 62
- “1170 Thermal module” on page 66

Attention: The CPU is extremely sensitive. When you service the CPU, avoid any kind of rough handling.

Removal steps of CPU

Rotate the head of the screw in the direction shown by the arrow **1** to release the lock, then remove the CPU **2**.

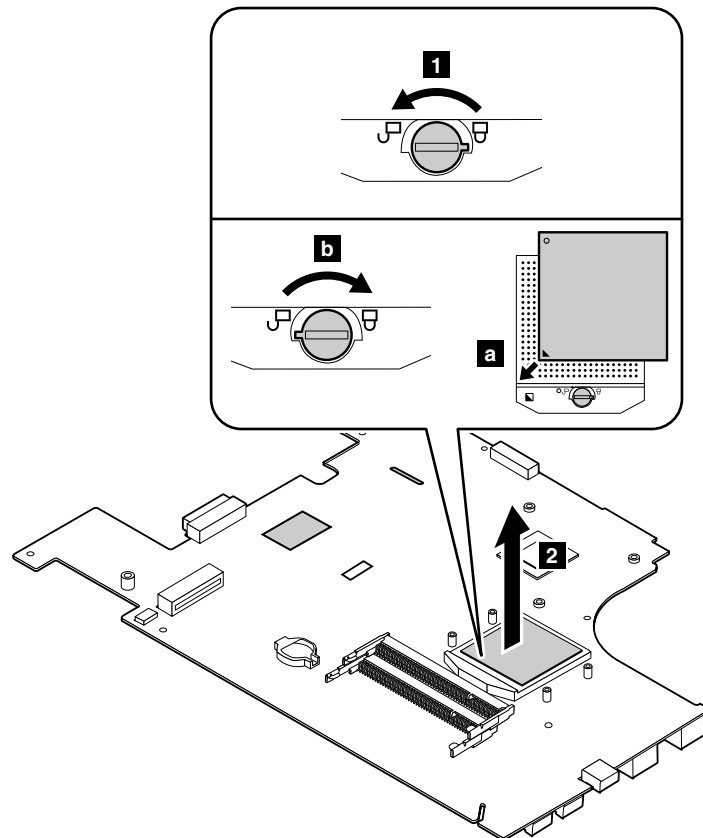

When installing: Place the CPU above the CPU socket **a**, and then rotate the head of the screw in the direction shown by the arrow **b** to secure the CPU.

1190 LCD unit

For access, remove these FRUs in order:

- “1010 Battery pack” on page 44
- “1020 Bottom slot cover” on page 44
- “1030 Optical drive” on page 45
- “1040 Memory modules” on page 46
- “1050 Hard disk drive assembly” on page 47
- “1060 PCI Express Mini Card for wireless LAN” on page 49
- “1070 mSATA solid state drive” on page 51
- “1080 Backup battery” on page 52
- “1090 Keyboard” on page 53

- “1100 Keyboard bezel” on page 56
- “1130 Microphone assembly” on page 60
- “1140 I/O board” on page 61
- “1150 System board assembly and USB board” on page 62
- “1160 DC-in connector” on page 65

Removal steps of LCD unit

Release the antenna cables from the cable guides. Then remove the screws **1**.

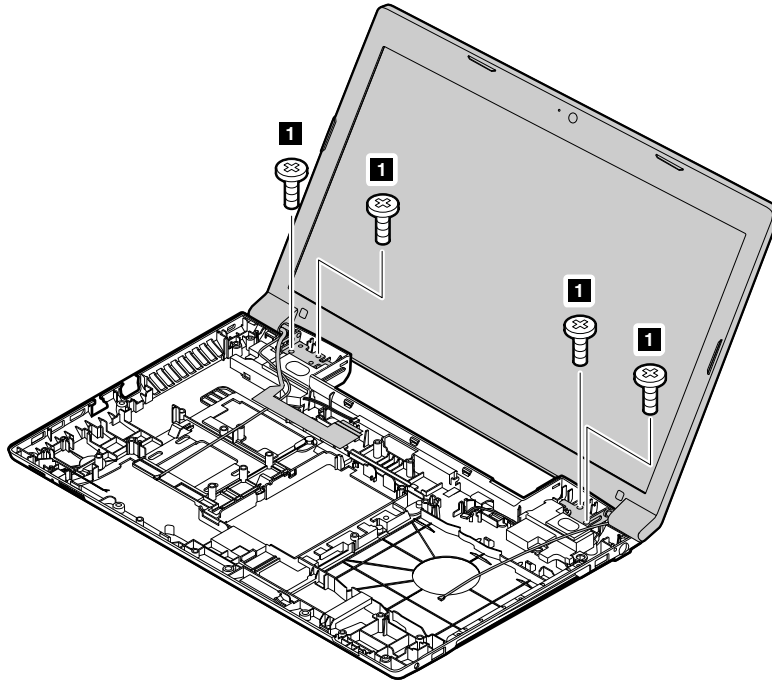

Step	Screw (quantity)	Color	Torque
1	M2.5 × 5 mm, flat-head, nylon-coated (4)	Black	4 kgf-cm

When installing:

- Route the antenna cables along the cable guides. As you route the cables, make sure that they are not subjected to any tension. Tension could cause the cables to be damaged by the cable guides, or a wire to be broken.
- Ensure that the LCD connector is attached firmly and make sure that you do not pinch the antenna cables when you attach the LCD assembly. Route the LCD cable along the cable guides.

Remove the LCD unit in the direction shown by the arrow **2**.

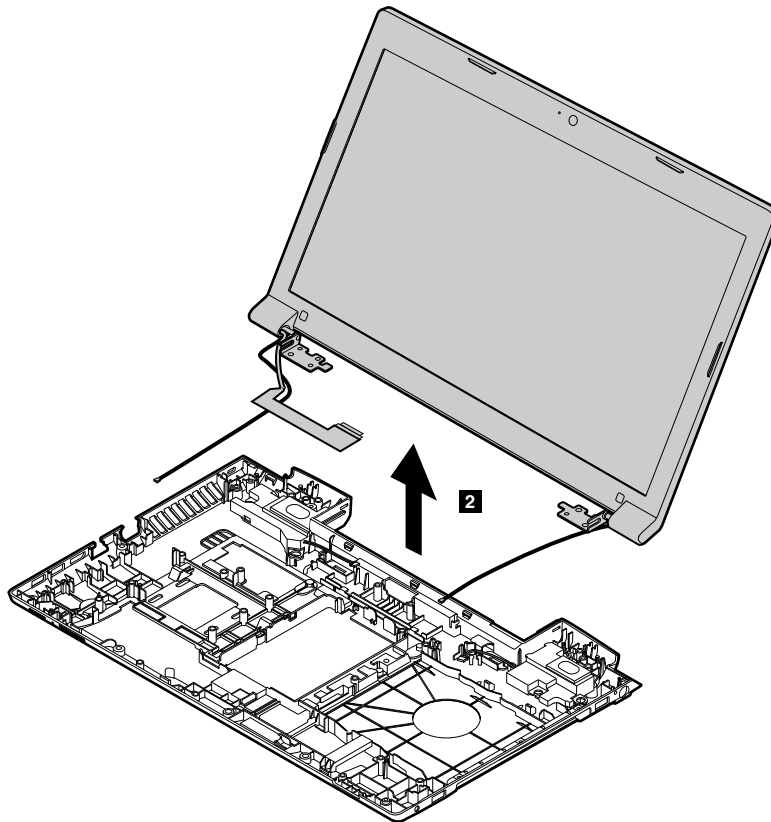

1210 Speaker assembly and base cover

For access, remove these FRUs in order:

- “1010 Battery pack” on page 44
- “1020 Bottom slot cover” on page 44
- “1030 Optical drive” on page 45
- “1040 Memory modules” on page 46
- “1050 Hard disk drive assembly” on page 47
- “1060 PCI Express Mini Card for wireless LAN” on page 49
- “1070 mSATA solid state drive” on page 51
- “1080 Backup battery” on page 52
- “1090 Keyboard” on page 53
- “1100 Keyboard bezel” on page 56
- “1130 Microphone assembly” on page 60
- “1140 I/O board” on page 61
- “1150 System board assembly and USB board” on page 62
- “1160 DC-in connector” on page 65
- “1190 LCD unit” on page 69

Removal steps of speaker assembly and base cover

Remove the screws **1**. Then remove the speaker assembly **2**.

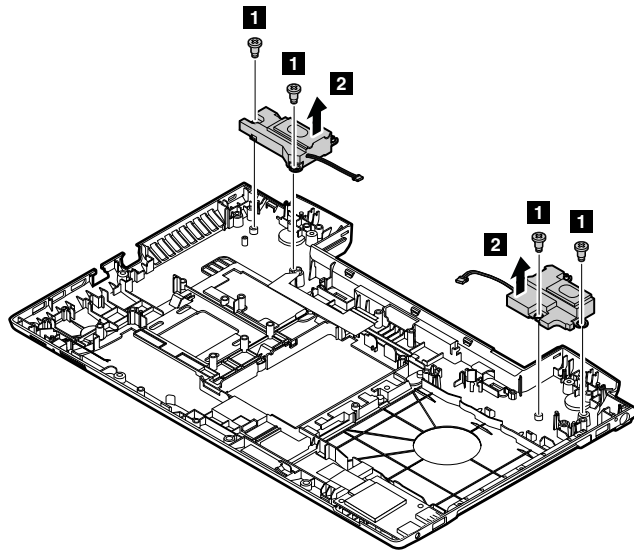

Step	Screw (quantity)	Color	Torque
1	M2.5 × 5.7 mm, flat-head, nylon-coated (4)	Black	4.0 kgf-cm

Applying labels to the base cover

The new base cover is shipped with a kit containing labels of several kinds. Apply those labels listed when you replace the base cover. For the labels which are not shipped with the new base cover, peel them off from the old base cover, and adhere them to the new one.

Note: If you replace a part with the Windows Certificate of Authentication (COA) label **11**, return the old part with the label attached to the customer. Otherwise, you can provide the customer with a letter, stating the original location of the label on the computer and the information on the label, such as the part number, serial number, and product key.

The following illustration shows the correct location of each label.

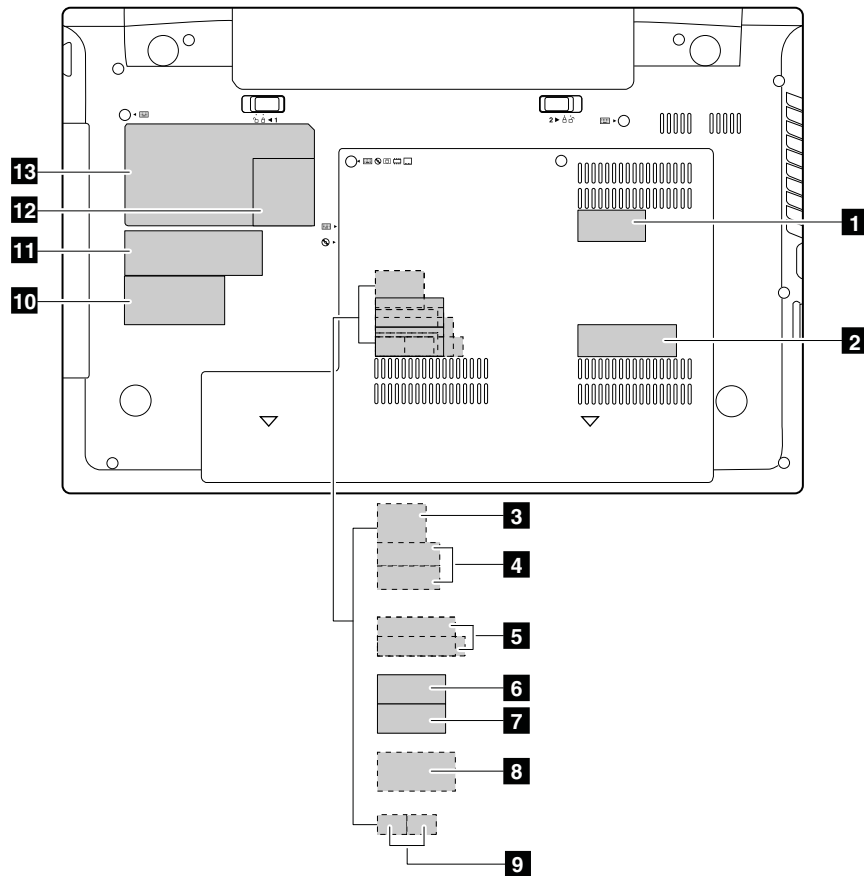

1 WWAN IMEI barcode label

2 China label, KCC label, or MAC label

3 Indonesia D side label

4 Indonesia WLAN and BT label

5 Israel label

6 Brazil Bluetooth label / Bluetooth label for United States/Canada/Taiwan

7 Brazil wireless LAN label or wireless LAN label for United States/Canada/Taiwan

8 PPT label

9 Malaysia SIRIM label

10 Vodafone label

12 Rating label

2010 LCD front bezel

For access, remove these FRUs in order:

- “1010 Battery pack” on page 44
- “1190 LCD unit” on page 69

Removal steps of LCD front bezel

Remove the screws **1**.

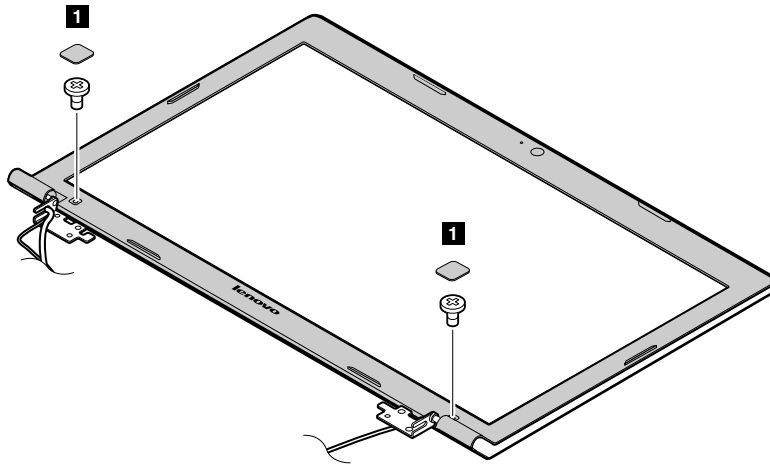

Step	Screw (quantity)	Color	Torque
1	M2 × 5 mm, flat-head, nylon-coated (2)	Black	1.85 kgf-cm

Remove the LCD front bezel in the direction shown by the arrows **2**.

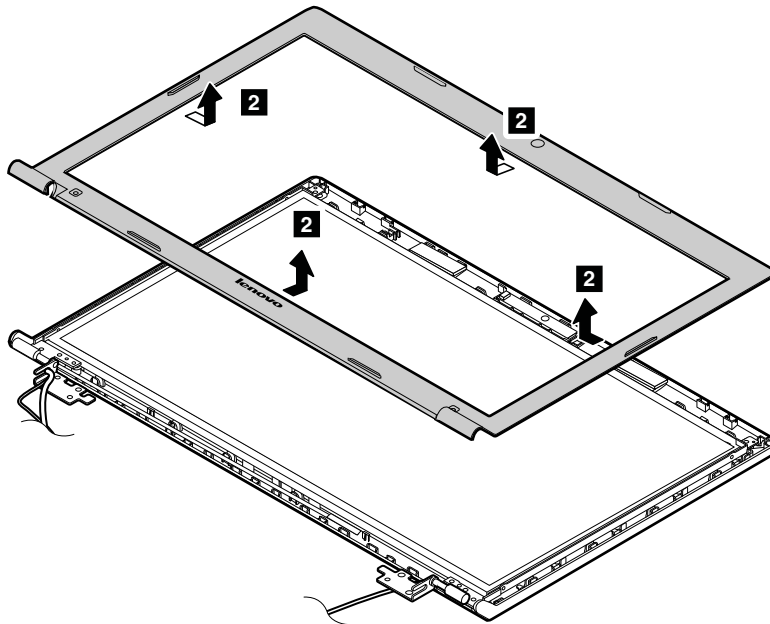

When installing: Make sure that all the latches are attached firmly. Then secure the bezel with the screws.

2020 Camera

For access, remove these FRUs in order:

- “1010 Battery pack” on page 44
- “1190 LCD unit” on page 69
- “2010 LCD front bezel” on page 73

Removal steps of camera

Remove the camera from the LCD cover as shown in the following illustration.

Note: The camera is stuck on the top center of the LCD cover.

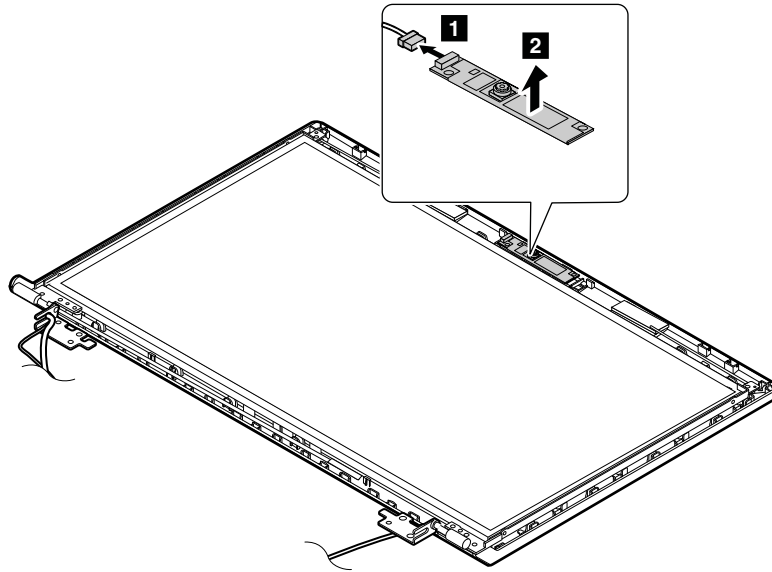

When installing: Stick the camera to the top center of the LCD cover and adjust the placement to ensure that the connector is attached firmly.

2030 LCD panel, LCD cable, and hinges

For access, remove these FRUs in order:

- “1010 Battery pack” on page 44
- “1190 LCD unit” on page 69
- “2010 LCD front bezel” on page 73

Removal steps of LCD panel and LCD cable

Remove the screws **1**. Then remove the LCD panel in the direction shown by the arrow **2**.

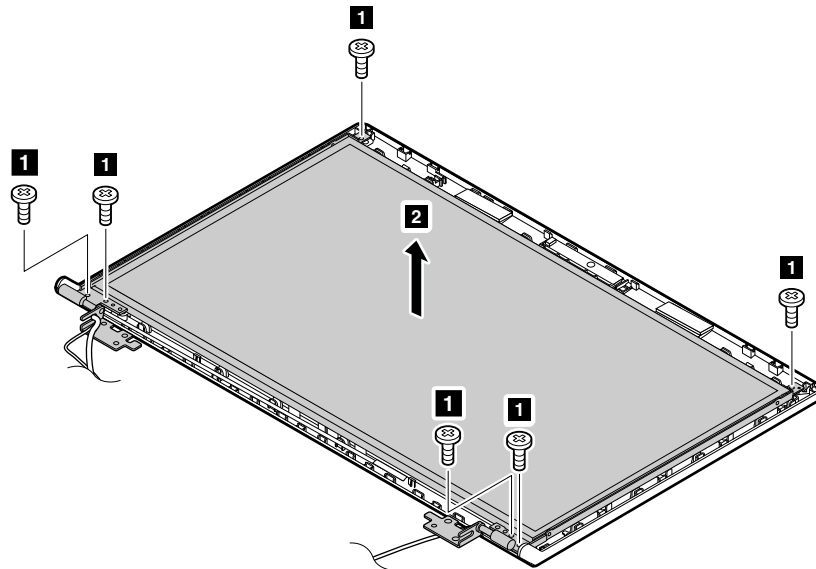

Step	Screw (quantity)	Color	Torque
1	M2 × 5 mm, flat-head, nylon-coated (6)	Black	1.85 kgf-cm

Turn over the LCD panel **3**. Remove the LCD cable.

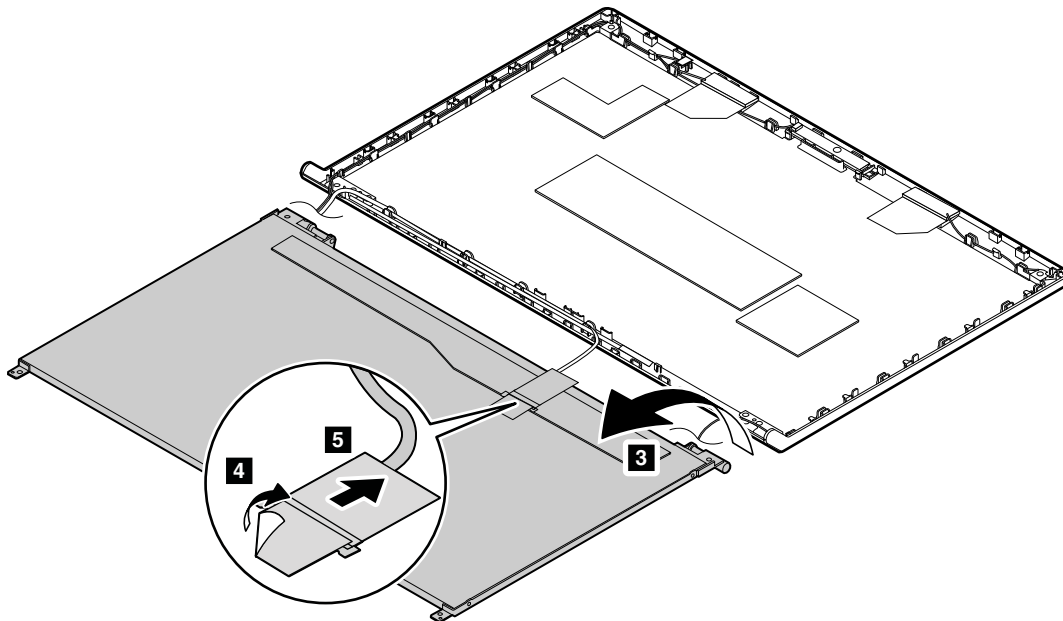

When installing: Ensure that the cable is attached firmly.

Removal steps of hinges

Remove the screws **1**. Then remove the hinges **2**.

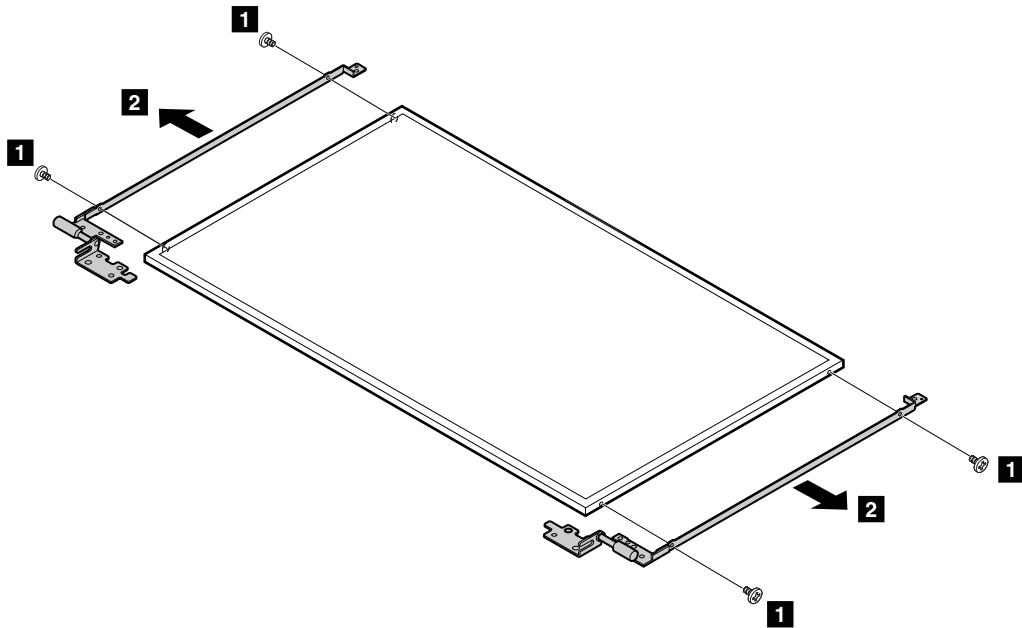

Step	Screw (quantity)	Color	Torque
1	M2 × 3 mm, flat-head, nylon-coated (4)	Black	1.85 kgf-cm

2040 Antenna assembly and LCD rear cover

For access, remove these FRUs in order:

- “1010 Battery pack” on page 44
- “1190 LCD unit” on page 69
- “2010 LCD front bezel” on page 73
- “2020 Camera” on page 74
- “2030 LCD panel, LCD cable, and hinges” on page 75

Removal steps of antenna assembly and LCD rear cover

Release the antenna cables from the cable guides of the LCD rear cover assembly and from the hinges in the direction shown by the arrows **1**.

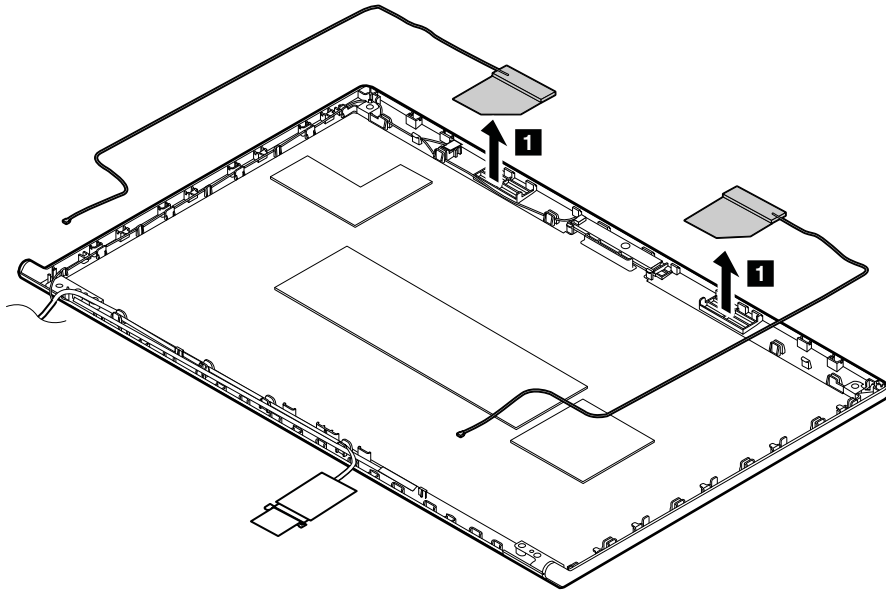

Cable routing: Route the antenna cables along the cable guides and secure the antenna boards with adhesive tapes. As you route the cables, make sure that they are not subjected to any tension. Tension could cause the cables to be damaged by the cable guides, or a wire to be broken.

Chapter 8. Locations

This chapter presents the locations of the Lenovo B590 hardware components.

Right-side view

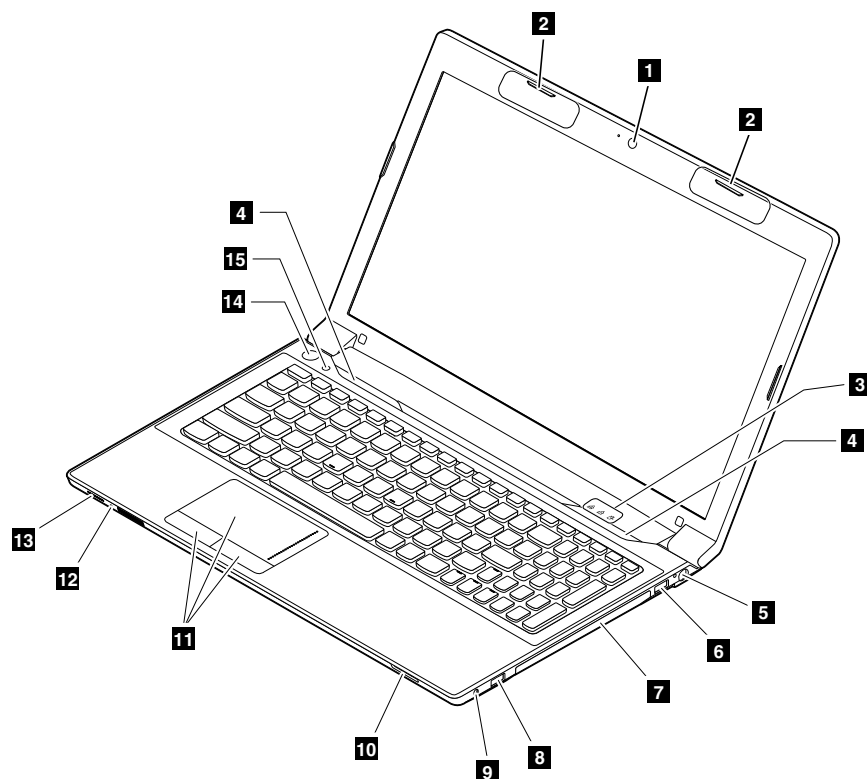

Figure 1. Lenovo B590 right-side view

- | | |
|---|--|
| 1 Camera (on some models) | 9 Combo audio jack |
| 2 Wireless module antennas | 10 Media card reader slot |
| 3 Status indicators ¹ | 11 Touch pad and touch pad buttons |
| 4 Speakers | 12 Microphone |
| 5 ac power connector | 13 Power and battery indicator ¹ |
| 6 USB connector | 14 Power button |
| 7 Optical drive | 15 Recovery button |
| 8 USB connector | |

¹ For the description of the indicators, see “Status indicators” on page 38.

Bottom view

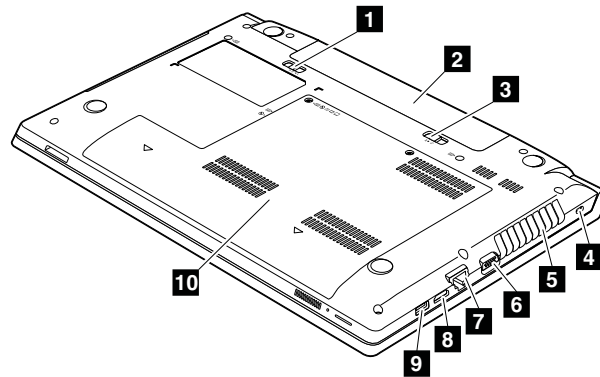

Figure 2. Lenovo B590 bottom view

- | | |
|---------------------------|--|
| 1 Battery lock | 6 Monitor connector |
| 2 Battery pack | 7 Ethernet connector |
| 3 Battery latch | 8 HDMI port |
| 4 Security keyhole | 9 USB 3.0 connector |
| 5 Fan louvers | 10 Bottom slot cover ¹ |

¹ The memory modules, hard disk drive, and wireless cards are located underneath the bottom slot cover.

Chapter 9. Parts list

This chapter contains following lists of the service parts.

- “Overall” on page 82
- “LCD FRUs” on page 85
- “Keyboard” on page 87
- “Miscellaneous parts” on page 89
- “ac power adapters” on page 90
- “Power cords” on page 91

Notes:

- Each FRU is available for all types or models, unless otherwise specified.
- A CRU is identified by a single asterisk (*) or two asterisks (**) in the CRU ID column. An N in the CRU ID column means that the part is not a CRU. A single asterisk (*) means that the part is a self-service CRU; two asterisks (**) means that the part is an optional-service CRU.

CRU statement for customers:

You can resolve some problems with your product with a replacement part you can install yourself, called a “Customer Replaceable Unit” or “CRU”. Some CRUs are designated as self-service CRUs and others are designated as optional-service CRUs. *Installation of self-service CRUs is your responsibility. For optional-service CRUs, you can either install the CRU yourself or you can request that a Service Provider install the CRU according to the warranty service for your product.* If you intend on installing the CRU, Lenovo will ship the CRU to you. CRU information and replacement instructions are shipped with your product and are available from Lenovo at any time upon request. You can find a list of CRUs for your product in this *Hardware Maintenance Manual*. An electronic version of this manual can be found at <http://www.lenovo.com/UserManuals>. Follow the on-screen instructions to find the manual for your product. You might be required to return the defective CRU. When return is required: (1) return instructions, a prepaid shipping label, and a container will be included with the replacement CRU; and (2) you might be charged for the replacement CRU if Lenovo does not receive the defective CRU within thirty (30) days of your receipt of the replacement CRU. See your Lenovo Limited Warranty documentation for full details.

Lenovo computers contain the following types of CRUs:

- **Self-service CRUs:** These CRUs unplug or are held by no more than two screws. Examples of these types of CRUs include the ac power adapter, power cord, battery, and hard disk drive. Other self-service CRUs depending on product design might include the memory module, wireless card, keyboard, and palm rest with finger print reader and touch pad.
- **Optional-service CRUs:** These CRUs are isolated parts within the computer that are concealed by an access panel that is typically secured by more than two screws. Once the access panel is removed, the specific CRU is visible.

Overall

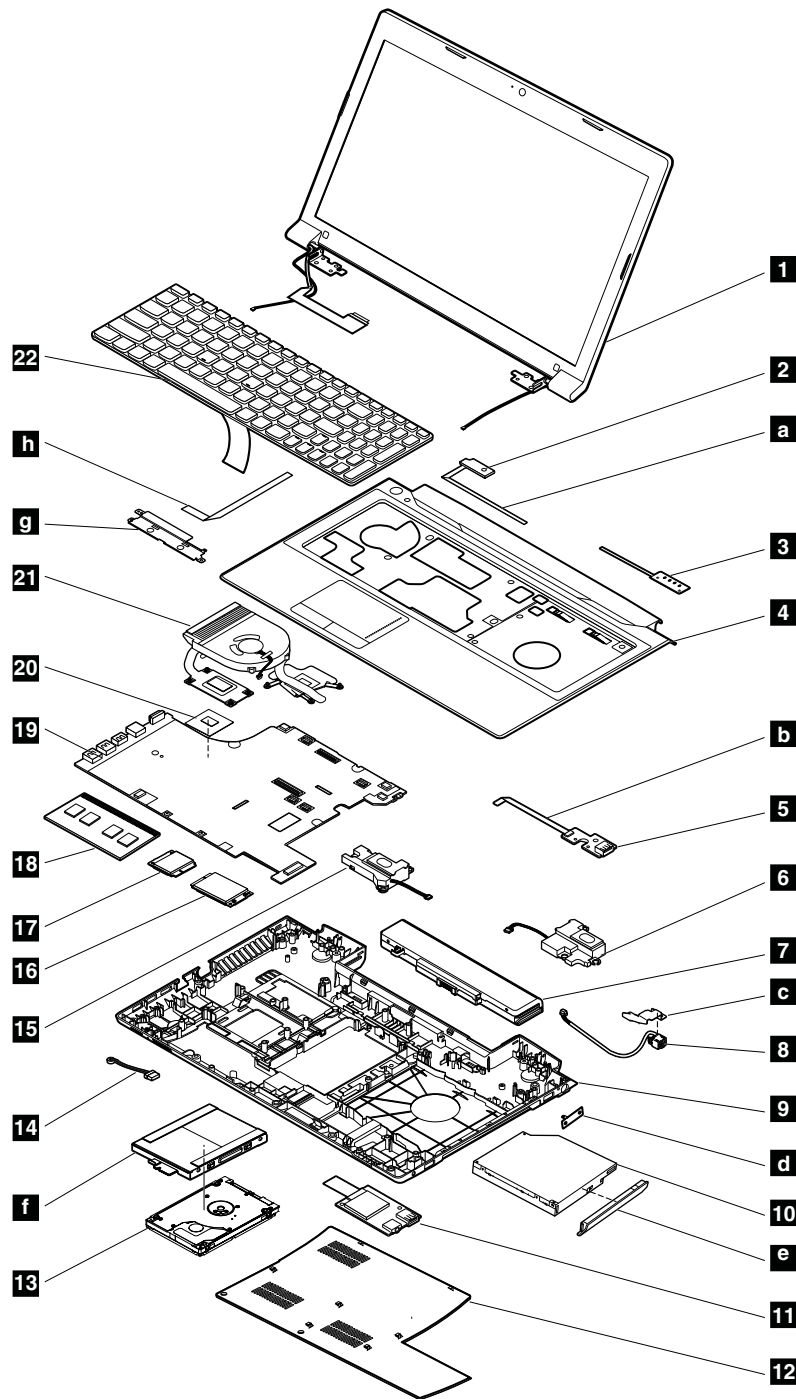

Table 3. Parts list—Overall

No.	FRU (Overall)	FRU no.	CRU ID
1	LCD unit (see “LCD FRUs” on page 85.)		
2	LB59A Power Board	90001037	N
3	LB58 LED Board W/Cable	90200814	N

Table 3. Parts list—Overall (continued)

No.	FRU (Overall)	FRU no.	CRU ID
4	LB59A Upper Case WO/FP	90201912	N
5	LB59A USB Board	90001035	N
6	LB58 Speaker R	90200832	N
7	Battery, 6CELL 2.2Ah, 48Wh, Sanyo	121500047	*
7	Battery, 6CELL 2.2Ah, 48Wh, Sony	121500048	*
7	Battery, 6CELL 2.2Ah, 48Wh, LG	121500049	*
7	Battery, 6CELL 2.2Ah, 48Wh, SMP	121500050	*
7	Battery, 6CELL 2.8Ah, L11L6F01 3S2P 62Wh Batt C01 Origa, LG	121500052	*
7	Battery, 6CELL 2.8Ah, SM/S L11M6F01 3S2P 62Wh Batt C01 Origa, SMP	121500053	*
8	LB58 DC-IN Cable	90200811	N
9	LB58 Lower Case	90200822	N
10	ODD, 12.7mm Tray-in Rambo, PLDS, DS-8A8SH	25201487	*
10	ODD, 12.7mm Tray-in Rambo, Sony Optiarc, AD-7740H	25201106	*
10	ODD, 12.7mm Tray-in Rambo, TSST, SN-208AB	25201108	*
10	ODD, 12.7mm Tray-in Rambo, HLDS, GT50N	25201635	*
11	LB58 IO Board	90000234	N
12	LB59A Memory Door	90201905	N
13	HDD, 320GB 5400rpm,, MN500S WD3200LPVT-08G33T1	16200265	**
13	HDD, 320GB 5400rpm, Toshiba Capricorn BS (H6sp) , Toshiba MK3265GSX 5400RPM 320G	16200097	**
13	HDD, 320GB 5400rpm, HGST Jaquar B7, HGST HTS545032A7E380 5400PRM7mm 320G	16200068	**
13	HDD, 320GB 5400rpm, Seagate Saptar 15, Seagate ST320LT020 5400RPM 7MM 320G	16005211	**
13	HDD, 500GB 5400rpm, WD ML500M, WD5000BPVT-08A1Y	16200118	**
13	HDD, 500GB 5400rpm, WD ML375M, WD5000BPVT-08HXZ	16200090	**
13	HDD, 500GB 5400rpm,, MN500S WD5000LPVT-08G33T1	16200264	**
13	HDD, 500GB 5400rpm, Toshiba Capricorn BS (H6sp), Toshiba MK5065GSX 5400RPM 500G	16200098	**
13	HDD, 500GB 5400rpm, HGST HTS545050A7E380 5400PRM7mm	16200067	**
13	HDD, 500GB 5400rpm, HTS547550A9E384 9.5mm Jet B	16200006	**
13	HDD, 500GB 5400rpm, ST500LM012 M8	16200210	**
13	HDD, 500GB 5400rpm, Yarra (1D) ST500LT012	16200211	**
13	HDD, 750GB 5400rpm, WD ML500M, WD7500BPVT-08A1Y	16200119	**
13	HDD, 750GB 5400rpm, WD ML375M, WD7500BPVT-08HXZ	16200121	**
13	HDD, 750GB 5400rpm, HGST Jaguar B, HTS541075A9E680	16200192	**
13	HDD, 750GB 5400rpm, ST750LM022 M8	16200209	**
13	HDD, 1TB 5400rpm, WD ML500M, WD10JPVT-08A1Y	16200120	**
13	HDD, 1TB 5400rpm, HGST Jaquar B, HTS541010A9E680	16200193	**
13	HDD, 1TB 5400rpm, ST1000LM024	16200208	**

Table 3. Parts list—Overall (continued)

No.	FRU (Overall)	FRU no.	CRU ID
13	HDD, 320GB 7200rpm, WD MX320S-1, WD3200BEKT-08PVM	16200092	**
13	HDD, 320GB 7200rpm, Toshiba Capricorn CS (H6sp), TSB MK3261GSY 7200PRM 9.5mm 320G HDD	16200099	**
13	HDD, 320GB 7200rpm, HGST Jaquar C7, HTS725032A7E630	16200194	**
13	HDD, 320GB 7200rpm, Seagate Julius 1 4K, Seagate ST320LT007 7200RPM 7MM 320G	16005030	**
13	HDD, 500GB 7200rpm, WD MX375M, WD5000BPKT-08PK4T	16200124	**
13	HDD, 500GB 7200rpm, Toshiba Capricorn CS (H6sp), TSB MK5061GSY 7200PRM 9.5mm 500G HDD	16200100	**
13	HDD, 500GB 7200rpm, Jaguar C7, HTS725050A7E630	16200195	**
14	LB58 Microphone	90200829	N
15	LB58 Speaker L	90200833	N
16	SSD, mSATA 16G, Sandisk, U100 mSATA SDSA5DK-016G	16200215	N
16	MZMPA016HMCD-000L1	16200255	N
17	WLAN, Non-Intel 1x1 11bgn + BT4.0 Combo, Broadcom 4313 + 20702	20200100 20200101	*
17	WLAN, Non-Intel 2x2 11abgn + BT4.0 Combo, Broadcom 43228 + 20702	20200098 20200099	*
17	WLAN, Intel 2x2 11bgn + BT4.0 Combo, Jackson Peak 1	20200078	*
17	WLAN, Non-Intel 1x1 11bgn, Broadcom BCM4313 1*1 BGN MOW	20200102	*
17	WLAN, Non-Intel 1x1 11bgn, Realtek bgn 1x1 HMC WLAN Stockton	20200016	*
18	Memory Module, DDRIII 1600 2GB, Samsung, M471B5773DH0-CK0 DDR3 1600 2GB	11200340	*
18	Memory Module, DDRIII 1600 2GB, Hynix, HMT325S6CFR8C-PB DDR3 1600 2GB	11200343	*
18	Memory Module, DDRIII 1600 2GB, Micron, MT8KTF25664HZ-1G6M1 DDR3 1600 2GB	11200346	*
18	Memory Module, DDRIII 1600 2GB, Memory Moduleaxel, RMT3150ED58E8W-1600 DDR3 1600 2GB	11200392	*
18	Memory Module, DDRIII 1600 2GB, Sharetronic(Micron), SM321NH08IAF DDR3 1600 2GB	11200396	*
18	Memory Module, DDRIII 1600 4GB, Samsung, M471B5273DH0-CK0 DDR3 1600 4GB	11200341	*
18	Memory Module, DDRIII 1600 4GB, Hynix, HMT351S6CFR8C-PB DDR3 1600 4GB	11200344	*
18	Memory Module, DDRIII 1600 4GB, Micron, MT16KTF51264HZ-1G6M1 DDR3 1600 4GB	11200347	*
18	Memory Module, DDRIII 1600 4GB, Ramaxel, RMT3160ED58E9W-1600 DDR3 1600 4GB	11200393	*
18	Memory Module, DDRIII 1600 4GB, Sharetronic(Micron), SM322NQ08IAF DDR3 1600 4GB	11200397	*
19	LB59A MB W8 UMA WO/SBA	90001836	N
19	LB59A MB W8P UMA WO/SBA	90001837	N
19	LB59A MB W8 DIS N13M-GE1 1G WO/SBA	90001838	N
19	LB59A MB W8P DIS N13M-GE1 1G WO/SBA	90001839	N
19	LB59B MB W8 UMA WO/SBA	90001840	N
19	LB59B MB W8P UMA WO/SBA	90001841	N
19	LB59B MB W8 DIS N13M-GE1 1G W/SBA	90001842	N
19	LB59B MB W8P DIS N13M-GE1 1G W/SBA	90001843	N

Table 3. Parts list—Overall (continued)

No.	FRU (Overall)	FRU no.	CRU ID
20	CPU, Intel I5-2520M 2.5G 3M 2c J1 PGA processor	102001067	N
20	CPU, Intel B815 1.6G Q0 2M 2cPGA processor	102500229	N
20	CPU, Intel I3-2370M 2.4G J1 3M 2cPGA processor	102500228	N
20	CPU, Intel SNB I3-2350M 2.3G 3M J1 PGA processor	102500018	N
20	CPU, Intel SNB I3-2330M 2.2G 3M J1 PGA processor	102500017	N
20	CPU, Intel SNB B950 2.1G 2M Q0 PGA processor	102500016	N
20	CPU, Intel SNB B940 2.0G 2M Q0 PGA processor	102500015	N
20	CPU, Intel SNB I3-2310M 2.1G 3M 2c J1 PGA processor	102001065	N
20	CPU, Intel B970 2.3G D2 2M 2cPGA processor	102500230	N
20	CPU, Intel SNB B800 1.5G Q0 2M 2c PGA processor	102500101	N
20	CPU, Intel SNB B960 2.2G 2M 35W PGA processor	102500133	N
20	CPU, Intel B820 1.7G Q0 2M 2cPGA processor	102500350	N
20	CPU, i5-3210M Ivy Bridge L-0 3MB 2c PGA 2.5GHz STD 35W processor	102500301	N
20	CPU, i3-3110M Ivy Bridge L-0 3MB 2c PGA 2.3GHz STD 35W processor	102500303	N
20	CPU, Intel B980 2.4G Q0 2M 2c PGA Processor	102500362	N
20	CPU, Intel B830 1.8G Q0 2M 2c PGA Processor	102500440	N
20	CPU, Intel I3-2328M 2.2G J1 3M 2c PGA Processor	102500421	N
21	LB59A Thermal Module DIS W/FAN	90201913	N
21	LB59A Thermal Module UMA W/FAN	90201914	N
22	Keyboard (see “Keyboard” on page 87.)		
—	ac power adapter (see “ac power adapters” on page 90.)		

LCD FRUs

In Lenovo B590 models, the type of LCD is 15.6-inch high definition (HD) TFT LCD (Table 4 “Parts list - LCD” on page 86).

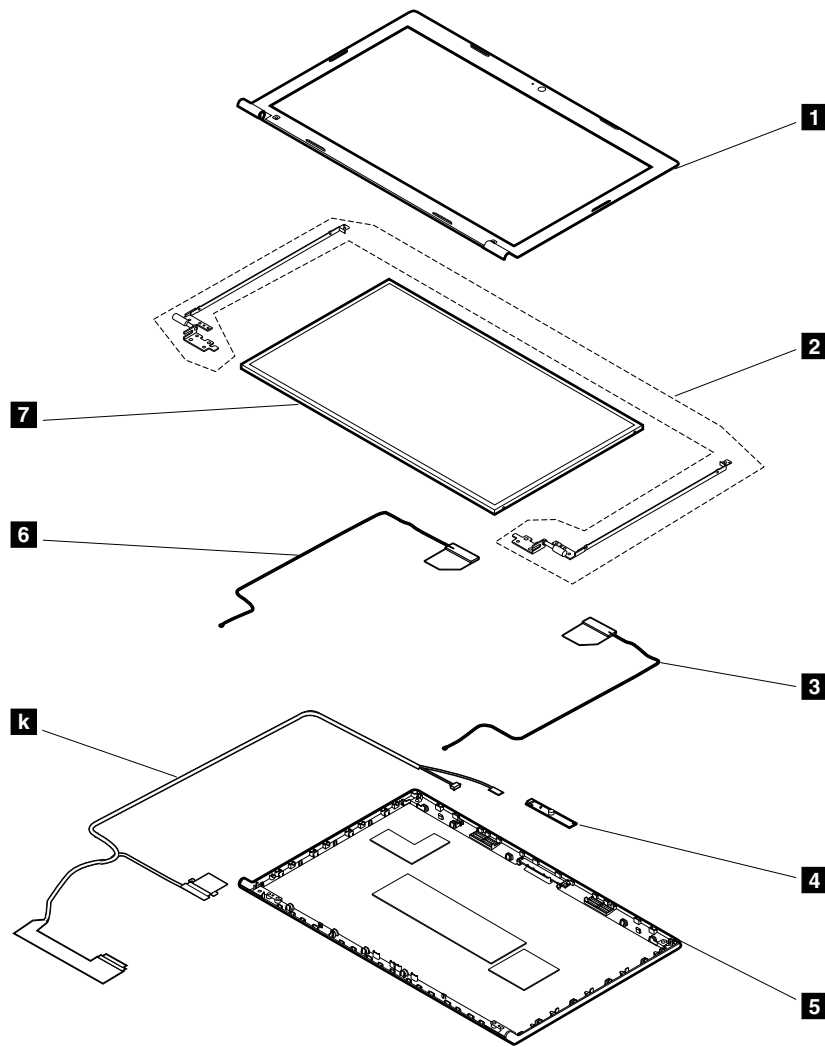

Table 4. Parts list - LCD

No.	FRU	FRU no.	CRU ID
1	LB59A LCD Bezel WO/Camera Hole	90201910	N
1	LB59A LCD Bezel W/Camera Hole	90201911	N
2	LB58 Hinge L+R	90200817	N
3	LB58 Antenna R	90200826	N
4	LB58 Camera 0.3M	90000238	N
5	LB59A LCD Cover	90201909	N
6	LB58 Antenna L	90200825	N
7	Panel, 15.6 HD Wedge Glossy, SEC, LTN156AT24-L01	18200114	N
7	Panel, 15.6 HD Wedge Glossy, LGD, LP156WH4-TLN1	18200158	N
7	Panel, 15.6 HD Wedge Glossy, AUO, B156XTN02.0	18200157	N
7	Panel, 15.6 HD Wedge Anti-Glare, AUO, B156XTN02.1	18200649	N
7	Panel, 15.6 HD Wedge Anti-Glare, SEC, LTN156AT24-401	18200650	N

Table 4. Parts list - LCD (continued)

No.	FRU	FRU no.	CRU ID
7	Panel, 15.6 HD Wedge Anti-Glare, CMI, N156BGE-L11	18200651	N
7	Panel, 15.6 HD Wedge Anti-Glare, LGD, LP156WH4-TLP1	18200652	N

Keyboard

Table 5. Parts list - Keyboard (Dafon)

Language	FRU NO. (Windows 7)	FRU NO. (Windows 8)	CRU ID
Arabic	25204626	25209766	N
Belgian	25204634	25209774	N
Brazilian Portuguese	25204627	25209767	N
Bulgarian	25204640	25209780	N
French, English	25204620	25209760	N
Czech, Slovak	25204639	25209779	N
C& Nordics	25204633	25209773	N
Dutch	25204629	25209769	N
French	25204624	25209764	N
German	25204625	25209765	N
Greek	25204630	25209770	N
Hebrew	25204631	25209771	N
Hungarian	25204632	25209772	N
Icelandic	25204635	25209775	N
Indian	25204641	25209781	N
Italian	25204614	25209754	N
Japanese	25204628	25209768	N
Korean	25204621	25209761	N
Latin	25204619	25209759	N
Portuguese	25204618	25209758	N
Russian	25204623	25209763	N
Slovenian	25204636	25209776	N
Swiss	25204637	25209777	N
Spanish	25204615	25209755	N
Thai	25204617	25209757	N
Traditional Chinese	25204622	25209762	N
Turkish	25204616	25209756	N
U.K. English	25204613	25209753	N
U.S. English	25204612	25209752	N
U.S. English (International, with a Euro symbol)	25204638	25209778	N

Table 6. Parts list - Keyboard (Sunrex)

Language	FRU NO. (Windows 7)	FRU NO. (Windows 8)	CRU ID
Arabic	25204656	25209796	N
Belgian	25204664	25209804	N
Brazilian Portuguese	25204657	25209797	N
Bulgarian	25204670	25209810	N
Czech, Slovak	25204669	25209809	N
C& Nordics	25204663	25209803	N
Dutch	25204659	25209799	N
French	25204654	25209794	N
French, English	25204650	25209790	N
German	25204655	25209795	N
Greek	25204660	25209800	N
Hebrew	25204661	25209801	N
Hungarian	25204662	25209802	N
Icelandic	25204665	25209805	N
Indian	25204671	25209811	N
Italian	25204644	25209784	N
Japanese	25204658	25209798	N
Korean	25204651	25209791	N
Latin	25204649	25209789	N
Portuguese	25204648	25209788	N
Russian	25204653	25209793	N
Swiss	25204667	25209807	N
Spanish	25204645	25209785	N
Slovenian	25204666	25209806	N
Thai	25204647	25209787	N
Traditional Chinese	25204652	25209792	N
Turkish	25204646	25209786	N
U.K. English	25204643	25209783	N
U.S. English	25204642	25209782	N
U.S. English (International, with a Euro symbol)	25204668	25209808	N

Table 7. Parts list - Keyboard (Chicony)

Language	FRU NO. (Windows 7)	FRU NO. (Windows 8)	CRU ID
Arabic	25204597	25209737	N
Belgian	25204604	25209744	N
Brazilian Portuguese	25204598	25209738	N
Bulgarian	25204610	25209750	N

Table 7. Parts list - Keyboard (Chicony) (continued)

Language	FRU NO. (Windows 7)	FRU NO. (Windows 8)	CRU ID
Czech, Slovak	25204609	25209749	N
C& Nordics	25204603	25209743	N
Dutch	25204599	25209739	N
French	25204595	25209735	N
French, English	25204591	25209731	N
German	25204596	25209736	N
Greek	25204600	25209740	N
Hebrew	25204601	25209741	N
Hungarian	25204602	25209742	N
Indian	25204611	25209751	N
Icelandic	25204605	25209745	N
Italian	25204585	25209725	N
Japanese	25204584	25209724	N
Korean	25204592	25209732	N
Latin	25204590	25209730	N
Portuguese	25204589	25209729	N
Russian	25204594	25209734	N
Slovenian	25204606	25209746	N
Swiss	25204607	25209747	N
Spanish	25204586	25209726	N
Thai	25204588	25209728	N
Traditional Chinese	25204593	25209733	N
Turkish	25204587	25209727	N
U.K. English	25204583	25209723	N
U.S. English	25204582	25209722	N
U.S. English (International, with a Euro symbol)	25204608	25209748	N

Miscellaneous parts

Table 8. Parts list - Miscellaneous parts

FRU	FRU no.	CRU ID
(a) LB58 Power Board Cable	90200809	N
(b) LB58 USB Cable	90000237	N
(c) LB58 DC-IN Bracket	90200821	N
(d) LA48 ODD Bracket 33.4TD06.001	90200518	N
(e) LB59A ODD Bezel	90201906	N
(f) LA48 HDD Bracket 60.4TE08.001	90200520	N

Table 8. Parts list - Miscellaneous parts (continued)

FRU	FRU no.	CRU ID
<i>(g)</i> LB58 TP Bracket	90200820	N
<i>(h)</i> LB58 TP Cable	90200813	N
LB58 Microphone Rubber	90200830	N
LB59A LCD Bezel Screw Pad	90201915	N

Note: Italicized letters in parentheses are references to the exploded view in “Overall” on page 82.

ac power adapters

Table 9. Parts list—2-pin (65 W) ac power adapters

FRU	FRU no.	CRU ID
ADP-65FD AA	36200289	*
PA-1650-71I	36200291	*
A065R049L	36200293	*
Delta ADP-65SB A, EPA model	36200143	*
Liteon PA-1650-53I, EPA model	36200144	*
Chicony Power A065R028L, EPA model	36200210	*

Table 10. Parts list—3-pin (65 W) ac power adapters

FRU	FRU no.	CRU ID
Delta ADP-65FD BA	36200288	*
Liteon PA-1650-72I	36200290	*
Chicony Power A065R050L	36200292	*
Delta ADP-65SB B, EPA model	36200033	*
Liteon PA-1650-54I, EPA model	36200034	*
Chicony Power A065R017L, EPA model	36200212	*

Table 11. Parts list—2-pin (90 W) ac power adapters

FRU	FRU no.	CRU ID
Delta ADP-90XD AA	36200295	*
Liteon PA-1900-71I	36200297	*
Chicony Power A090A057L	36200299	*
Delta PA-1900-53I, EPA model	36200147	*
Liteon ADP-90ZH CA, EPA model	36200149	*
Chicony Power HP-A0905A2C1LF, EPA model	36200150	*

Table 12. Parts list—3-pin (90 W) ac power adapters

FRU	FRU no.	CRU ID
Delta ADP-90XD BA, EuP model	36200294	*
LITEON PA-1900-72I, EuP model	36200296	*
Chicony A090A058L, EuP model	36200298	*
Liteon PA-1900-54I, EPA model	36200030	*
Delta ADP-90ZH DA, EPA model	36200031	*
Chicony Power HP-BT090E13LF, EPA model	36200032	*

Power cords

A Lenovo power cord for a specific country or region is usually available only in that country or region.

Table 13. Parts list - 3-pin power cords (Linetek)

Country or region	FRU no.	CRU ID
Argentina • LINETEK LS15+H03VV-F+LP39 1 m	145000599	*
Australia, New Zealand • LINETEK LS15+H03VV-F+LP-23A 1 m	145000589	*
Brazil • LINETEK LS15 H03VV-F LP26A 1 m	145000596	*
CE • LINETEK LP-34+H03VV-F + LS15 1 m	145000585	*
China • LINETEK PC323+RVV300/300+LS15 1 m	145000600	*
Denmark • LINETEK LS15+H03VV-F+LP-38 1 m	145000598	*
Indian • LINETEK PE-361+ H05VV-F+ LS15 1 m	145000592	*
Israel • LINETEK LS15+H03VV-F+LP-41 1 m	145000595	*
Italy • LINETEK LS15+H03VV-F+PE-336 1 m	145000591	*
Japan • LINETEK LS15+VCTF+LP-54 1 m	145000587	*
Korea • LINETEK LS15+H05VV-F+LP-E04A 1 m	145000590	*
South Africa • LINETEK LS15+H03VV-F+PE-364 1 m	145000586	*

Table 13. Parts list - 3-pin power cords (Linetek) (continued)

Country or region	FRU no.	CRU ID
Switzerland • LINETEK LS15+H03VV-F+LP-37 1 m	145000597	*
Taiwan • LINETEK LS15+VCTF+LP-53 1 m	145000588	*
U.K. • LINETEK LP-61L+ H03VV-F+ LS15 1 m	145000593	*
UL • LINETEK LP-30B + SPT-2 + LS15 1 m	145000594	*

Table 14. Parts list - 3-pin power cords (Longwell)

Country or region	FRU no.	CRU ID
Argentina • Longwell LP-24+H03VV-F+LS-18 1 m	145000567	*
Australia, New Zealand • Longwell LP-23A+LFC-3R+LS-18 1 m	145000557	*
Brazil • Longwell LP-46+H03VV-F+LS-18 1 m	145000564	*
CE • Longwell LP-34A+H03VV-F+LS-18 1 m	145000553	*
China • Longwell LSG-31+RVV300/300+LS-18 1 m	145000568	*
Denmark • Longwell LP-40+H03VV-F+LS-18 1 m	145000566	*
Indian • Longwell LP-67+BIS+LS-18 1 m	145000560	*
Israel • Longwell LP-41+H03VV-F+LS-18 1 m	145000563	*
Italy • Longwell LP-22+H03VV-F+LS-18 1 m	145000559	*
Japan • Longwell LP-54+VCTF+LS-18 1 m	145000555	*
Korea • Longwell LP-486+KTLH03VV-F+LS-5 1 m	145000558	*
South Africa • Longwell LP-39+H03VV-F+LS-18 1	145000554	*
Switzerland • Longwell LP-37+H03VV-F+LS-18 1 m	145000565	*

Table 14. Parts list - 3-pin power cords (Longwell) (continued)

Country or region	FRU no.	CRU ID
Taiwan • Longwell LP-71+VCTF+LS-33 1 m	145000556	*
U.K. • Longwell LP-61L+H03VV-F+LS-18 1 m	145000561	*
UL • Longwell LP-30B+SPT-2 18AWG+LS-18 1 m	145000562	*

Table 15. Parts list - 3-pin power cords (Volex)

Country or region	FRU no.	CRU ID
Argentina • VOLEX VA2073+H03VV-F+VAC5S 1 m	145000528	*
Australia, New Zealand • VOLEX AU10S3+H03VV-F+VAC5S 1 m	145000532	*
Brazil • VOLEX CH10S3+H03VV-F+VAC5S 1 m	145000527	*
CE • VOLEX M2511+H03VV-F+VAC5S 1 m	145000525	*
China • VOLEX GB10S3+RVV 300/500+VAC5S 1 m	145000538	*
Denmark • VOLEX MP233D+H03VV-F+VAC5S 1 m	145000534	*
Indian • VOLEX IA6A3+IS694+VAC5S 1 m	145000536	*
Israel • VOLEX SI16S3+H03VV-F+VAC5S 1 m	145000526	*
Italy • VOLEX IT10S3+H03VV-F+VAC5S 1 m	145000535	*
Japan • VOLEX VAC5S+VCTF+M755 1 m	145000530	*
Korea • VOLEX M2511+KETI IEC+VAC5S 1 m	145000533	*
South Africa • VOLEX SA16A+H03VV-F+VAC5S 1 m	145000529	*
Switzerland • VOLEX MP232+H03VV-F+VAC5S 1 m	145000524	*
Taiwan • VOLEX TW15CS3+VCTF+VAC5S 1 m	145000531	*

Table 15. Parts list - 3-pin power cords (Volex) (continued)

Country or region	FRU no.	CRU ID
U.K. • VOLEX MP5004+H03VV-F+VAC5S 1 m	145000605	*
UL • Volex US15S3+SPT-2 + VAC5S 1 m	145000537	*

Table 16. Parts list - 2-pin power cords (Linetek)

Country or region	FRU no.	CRU ID
Africa • LINETEK PE364("O")+H03VVH2-F+LS7H 1 m	145500024	*
Argentina • LINETEK LP40+H03VVH2-F+LS7H 1 m	145500030	*
Australia • LINETEK LP15A+H03VVH2-F+LS7 1 m	145500023	*
Brazil • LINETEK LP25+H03VVH2-F+LS7H 1 m	145500028	*
CCC • LINETEK PC205+RVV 0.75/2C+COC03 1 m	145500018	*
CE • LINETEK LP21+H03VVH2-F+ LS7 1 m	145500022	*
India • LINETEK LP28+IS:694 0.75/2C+ LS7H 1 m	145500020	*
Israel • LINETEK LP45+H03VV-F+LS7 1 m	145500029	*
Japan • LINETEK LP51A+HVCTFK 0.75/2C+LS7J 1 m	145500026	*
Korea • LINETEK LPE03A+H03VVH2-F+LS7 1 m	145500025	*
Taiwan • LINETEK LP51A+VCTFK 0.75/2C+LS7J 1 m	145500027	*
UL • LINETEK LP5+SPT-2 #18/2C+ LS7C 1 m	145500021	*
UK • LINETEK LP61L+H03VVH2-F+ LS7H 1 m	145500019	*

Appendix A. Notices

Lenovo may not offer the products, services, or features discussed in this document in all countries. Consult your local Lenovo representative for information on the products and services currently available in your area. Any reference to a Lenovo product, program, or service is not intended to state or imply that only that Lenovo product, program, or service may be used. Any functionally equivalent product, program, or service that does not infringe any Lenovo intellectual property right may be used instead. However, it is the user's responsibility to evaluate and verify the operation of any other product, program, or service.

Lenovo may have patents or pending patent applications covering subject matter described in this document. The furnishing of this document does not give you any license to these patents. You can send license inquiries, in writing, to:

*Lenovo (United States), Inc.
1009 Think Place - Building One
Morrisville, NC 27560
U.S.A.
Attention: Lenovo Director of Licensing*

LENOVO PROVIDES THIS PUBLICATION "AS IS" WITHOUT WARRANTY OF ANY KIND, EITHER EXPRESS OR IMPLIED, INCLUDING, BUT NOT LIMITED TO, THE IMPLIED WARRANTIES OF NON-INFRINGEMENT, MERCHANTABILITY OR FITNESS FOR A PARTICULAR PURPOSE. Some jurisdictions do not allow disclaimer of express or implied warranties in certain transactions, therefore, this statement may not apply to you.

This information could include technical inaccuracies or typographical errors. Changes are periodically made to the information herein; these changes will be incorporated in new editions of the publication. Lenovo may make improvements and/or changes in the product(s) and/or the program(s) described in this publication at any time without notice.

The products described in this document are not intended for use in implantation or other life support applications where malfunction may result in injury or death to persons. The information contained in this document does not affect or change Lenovo product specifications or warranties. Nothing in this document shall operate as an express or implied license or indemnity under the intellectual property rights of Lenovo or third parties. All information contained in this document was obtained in specific environments and is presented as an illustration. The result obtained in other operating environments may vary.

Lenovo may use or distribute any of the information you supply in any way it believes appropriate without incurring any obligation to you.

Any references in this publication to non-Lenovo Web sites are provided for convenience only and do not in any manner serve as an endorsement of those Web sites. The materials at those Web sites are not part of the materials for this Lenovo product, and use of those Web sites is at your own risk.

Any performance data contained herein was determined in a controlled environment. Therefore, the result obtained in other operating environments may vary significantly. Some measurements may have been made on development-level systems and there is no guarantee that these measurements will be the same on generally available systems. Furthermore, some measurements may have been estimated through extrapolation. Actual results may vary. Users of this document should verify the applicable data for their specific environment.

Electronic emissions notices

For electronic emission information on Class B digital devices, refer to the corresponding information in the *User Guide*.

EU contact: Lenovo, Einsteinova 21, 851 01 Bratislava, Slovakia



Trademarks

The following terms are trademarks of Lenovo in the United States, other countries or both:

Lenovo
OneKey

Windows is the trademark of the Microsoft group of companies.

Intel is the trademark of Intel Corporation or its subsidiaries in the United States, other countries, or both.

Other company, product, or service names may be the trademarks or service marks of others.

lenovo[®]

Part Number:

Printed in China

(1P) P/N:

